

KURUMSAL CORPORATE

2004 yılından bugüne sanayi sektöründe faaliyet gösteren firmamız, 2013 yılında BI-AX Cutting Tools markası ile kesici uç bağlama ekipmanlarının üretimine başlamıştır.

Kurulduğu günden beri büyük bir azim ve sabırla çalışarak, Türkiye ve Avrupa ülkeleri başta olmak üzere dünyanın birçok ülkesinde ürünlerini satışa sunmaktadır.

Firmamız gelişen teknolojiye ayak uydurarak ,makina parkurunu arttırmış ve oluşturduğu bilgisayarlı tezgahlarla ürün çeşitliliğini arttırmasının yanısıra sektörde aranan bir marka haline gelmiştir.

Müşteri memnuniyetini herşeyden üstün tutan firmamız ,siz değerli müşterilerine kaliteli ürün sunmakta ve ürün fiyatlarını piyasa koşullarının altında tutmaktadır.

Gelişen,değişen ve dinamik yapısı ile gelecek yıllarda da siz değerli müşterilerine yenilikçi ürünler sunmaya devam etmektedir.

Our company,which has been carrying on business since 2004 in industry sector,is manufacturing cutting tip fasteners under the brand name BI-AX Cutting Tools in 2013. Our company has been working with a great confidence and patience since its establishment and now we are making sales to many countries ,especially Turkey and European countries.

Our company has kept up with technology ,improved its machine park and increased product range capacity with computerized workbenches ,also achieved to become a demanded brand in the market by maximizing product quality. Our company has aspired to keep the customer satisfaction in highest level and in this context ,achieved to increase product quality and to keep the prices under market conditions.

Our company,which not only uses the technology ,but also understands and develops it,which has been in a dynamic process since its establishment,continues the works that will broaden horizons in the next years.

İÇİNDEKİLER
INDEX

T SİSTEM DIŞ TORNA KATERLERİ T System External Lathe Tool Holders	4 - 10
M SİSTEM DIŞ TORNA KATERLERİ M System External Lathe Tool Holders	12 - 13
S SİSTEM DIŞ TORNA KATERLERİ S System External Lathe Tool Holders	15 - 23
T SİSTEM DELİK TORNA KATERLERİ T System Boring Bars	25 - 29
M SİSTEM DELİK TORNA KATERLERİ M System Boring Bars	31 - 32
S SİSTEM DELİK TORNA KATERLERİ S System Boring Bars	34 - 43
DIŞ ÇAP KANAL AÇMA TAKIMLARI External Grooving Toolholders	44 - 48
DIŞ ÇAP ALIN KANAL AÇMA TAKIMLARI Face External Grooving Toolholders	49
DELİK İÇİ KANAL AÇMA TAKIMLARI Internal Grooving Toolholders	51 - 53
DIŞ ve İÇ ÇAP DİŞ AÇMA TAKIMLARI External and Internal Threading Toolholders	55
S SİSTEM FREZELER T System end Mills	57 - 62
KÜRE UÇLU PARMAK FREZELER Ball Nose end Mills	64
T KANAL FREZELER T System Milling	66
DİSK FREZELER Disc Milling	68
S SİSTEM PAH FREZELER S System Chamfering and Mills	69
S SİSTEM MODÜLER FREZELER S System Modular end Mills	70
S SİSTEM HELİSEL FREZELER S System Helix end Mills	70
S SİSTEM KIRLANGIÇ FREZELER S System Helix end Mills	70
YÜZEY FREZELER Face Milling Cutter	72 - 82
DEĞİŞKEN UÇLU MATKAPLAR U -Drill	84 - 97
TIRTIR ve PUNTALAMA TAKIMLARI Center Tools	98
YEDEK PARÇALAR Spare Parts	100 - 103



T SİSTEM DIŞ TORNA KATERLERİ

T SYSTEM EXTERNAL LATHE TOOLHOLDERS



BL-AX
CUTTING TOOLS
TCLNR 25 25 M12

TSBP
CNM.12
M4
M6
A43
Z1501Z

T SİSTEM DIŞ TORNA KATERLERİ T System External Lathe Tool Holders

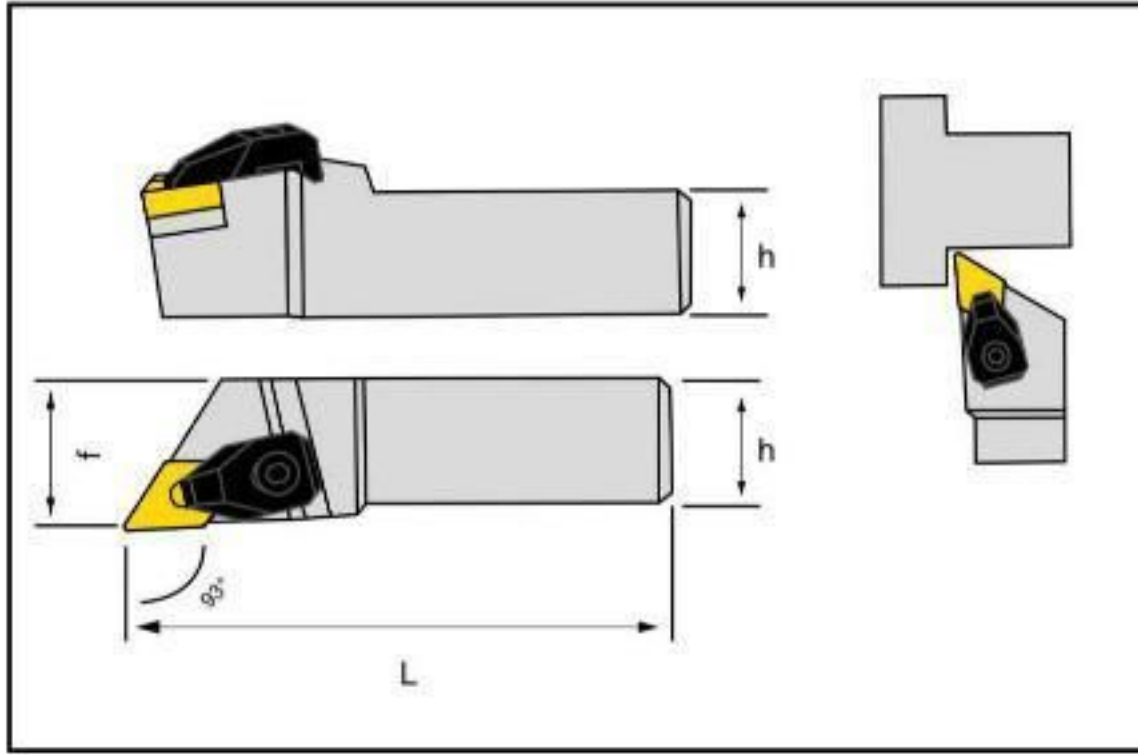

KOD CODE	ÖLÇÜLER DIMENSION (mm)				KESİCİ UÇ INSERT	YEDEK PARÇALAR SPARE PARTS					
	h	b	L	f		Baskı Parçası Clamp	Baskı Vidası Screw	Altlık Shim	Altlık Vidası Shim Screw	Pul Stamp	Anahtar Allen Key
TDJNR/L											
1616 H11	16	16	100	20	DNM.11 04	TSK2	TSBV M5x23,5	BAX DN11	TSAV M4X10	TSP 6,5X12	AA3
2020 K11	20	20	125	25							
2525 M11	25	25	150	32							
2020 K15	20	20	125	25	DNM.15 06	TSK1	TSBV M6x30	BAX DN15	TSAV M4X10	TSP 6,5X12	AA3
2525 M15	25	25	150	32							
3232 P15	32	32	170	40							
4040 S15	40	40	250	50							

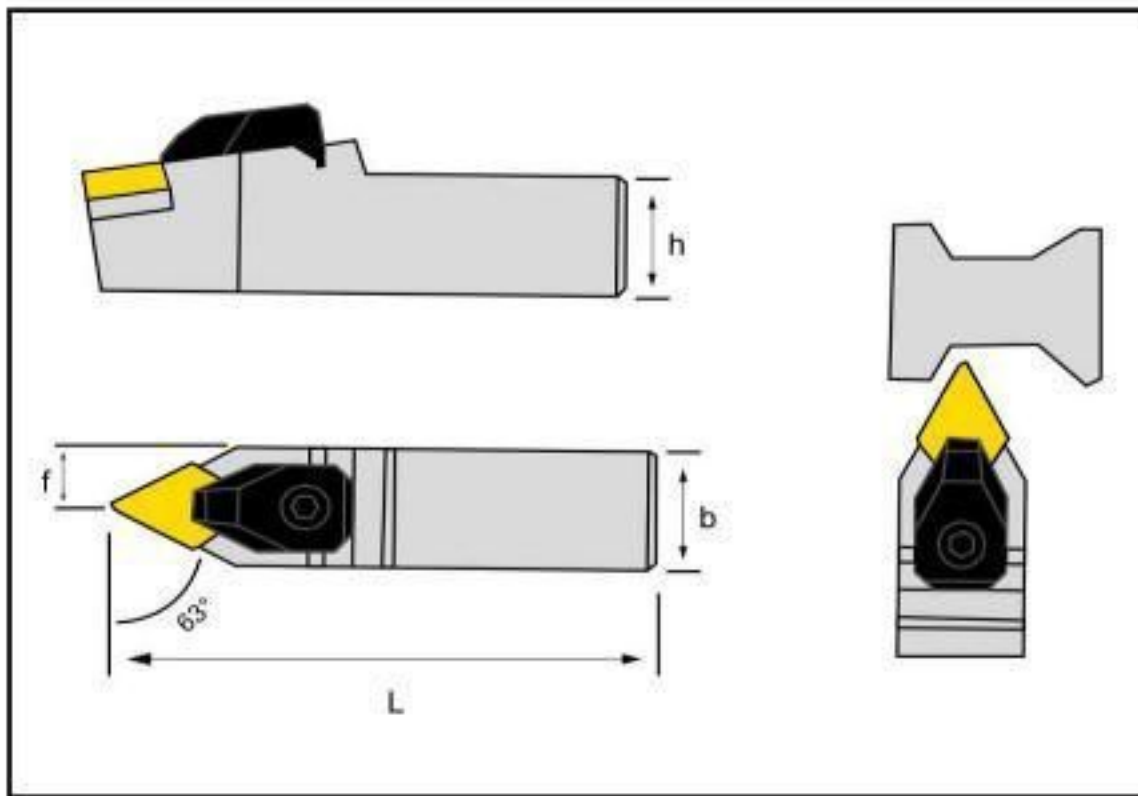

KOD CODE	ÖLÇÜLER DIMENSION (mm)				KESİCİ UÇ INSERT	YEDEK PARÇALAR SPARE PARTS					
	h	b	L	f		Baskı Parçası Clamp	Baskı Vidası Screw	Altlık Shim	Altlık Vidası Shim Screw	Pul Stamp	Anahtar Allen Key
TDNNN											
1616 H11	16	16	100	8	DNM.11 04	TSK2	TSBV M5x23,5	BAX DN11	TSAV M4X10	TSP 6,5X12	AA3
2020 K11	20	20	125	10							
2525 M11	25	25	150	12,5							
2020 K15	20	20	125	10	DNM.15 06	TSK1	TSBV M6x30	BAX DN15	TSAV M4X10	TSP 6,5X12	AA3
2525 M15	25	25	150	12,5							
3232 P15	32	32	170	16							
4040 S15	40	40	250	20							

T SİSTEM DIŞ TORNA KATERLERİ

T System External Lathe Tool Holders

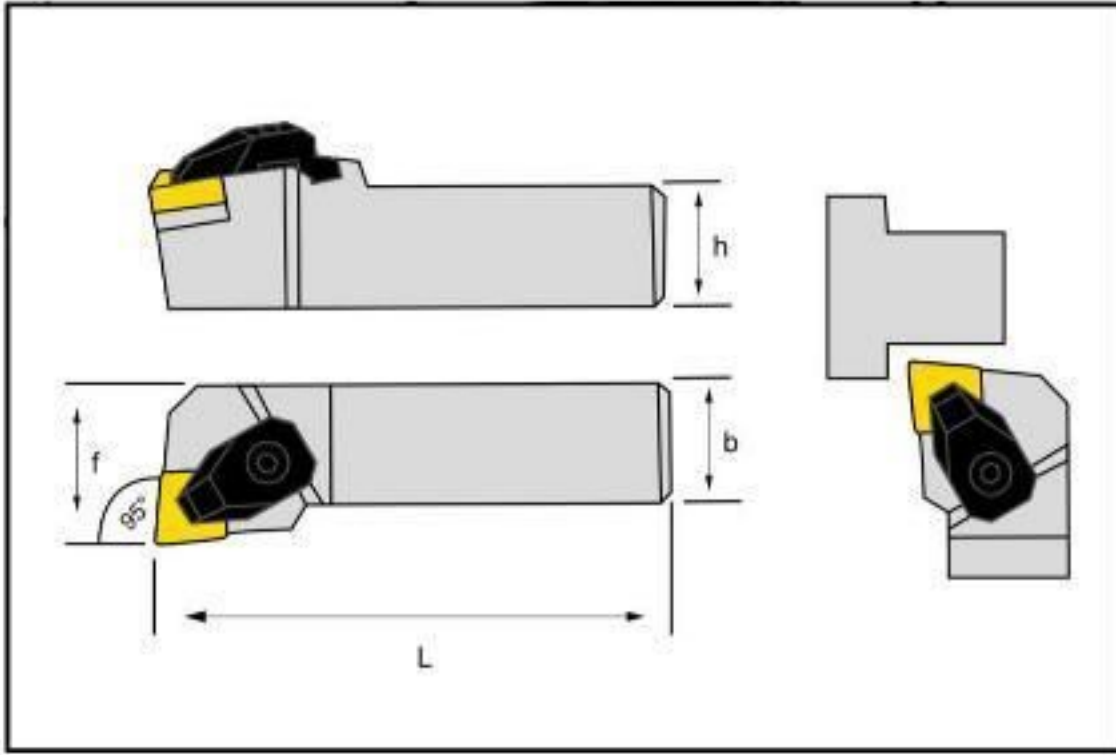



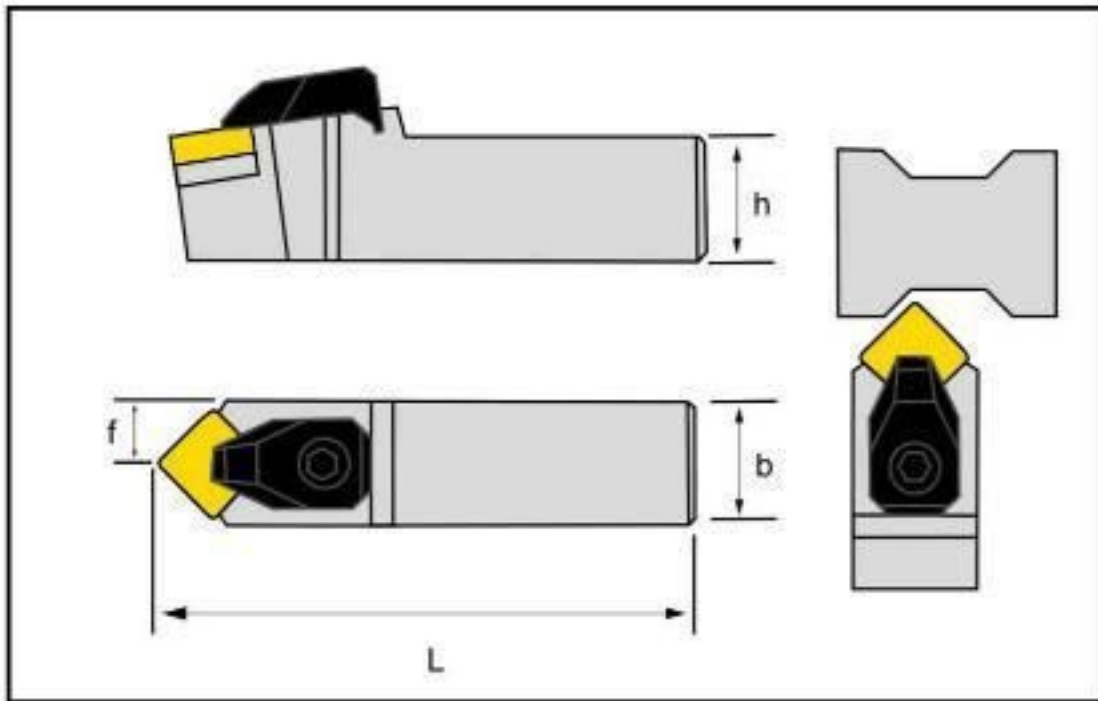

KOD CODE	ÖLÇÜLER DIMENSION (mm)				KESİCİ UÇ INSERT	YEDEK PARÇALAR SPARE PARTS					
	h	b	L	f		Baskı Parçası Clamp	Baskı Vidası Screw	Altık Shim	Altık Vidası Shim Screw	Pul Stamp	Anahtar Allen Key
TCLNR/L											
2020 K12	20	20	125	25	CNM.12 04..	TSK1	TSBV	BAX-CN12	TSAV M4X10	"TSP	AA3
2525 M12	25	25	150	32							
3232 P12	32	32	170	40							
2525 M16	25	25	150	32	CNM.16 06..	TSK3	TSBV M6X30x7	BAX- CN16	TSAV M6X16		AA4
3232 P16	32	32	170	40							
4040 S16	40	40	250	50							
3232 P19	32	32	170	40	CNM 19 09..	TSK4	TSBV M8X30	BAX- CN19	TSAV M6X16		AA4
4040 S19	40	40	250	50							

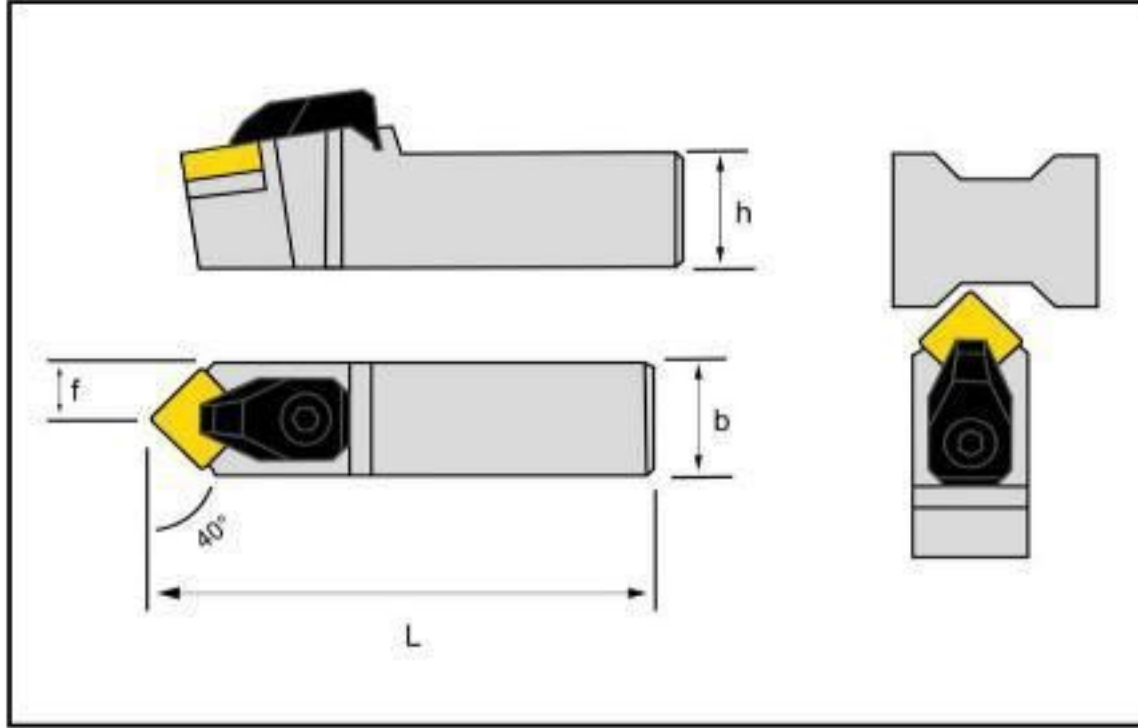

KOD CODE	ÖLÇÜLER DIMENSION (mm)				KESİCİ UÇ INSERT	YEDEK PARÇALAR SPARE PARTS					
	h	b	L	f		Baskı Parçası Clamp	Baskı Vidası Screw	Altık Shim	Altık Vidası Shim Screw	Pul Stamp	Anahtar Allen Key
TCMNN											
1616 H12	16	16	100	8	CNM.12 04..	TSK1	TSBV M6x30	BAX-CN12	"TSAV M4X10"	TSP 6,5X12	AA3
2020 K12	20	20	125	10							
2525 M12	25	25	150	12,5							
3232 P12	32	32	170	16							
3232 P16	32	32	170	16	CNM.16 06..	TSK3	TSBV M6X30x7	BAX- CN16	"TSAV M6X16"		AA4
4040 P16	40	40	250	20							
3232 P19	32	32	170	16							
4040 S19	40	40	250	20	CNM 19 09..	TSK4	TSBV M8X30	BAX- CN19	TSAV M6X16		AA4

T SİSTEM DIŞ TORNA KATERLERİ T System External Lathe Tool Holders



KOD CODE	ÖLÇÜLER DIMENSION (mm)				KESİCİ UÇ INSERT	YEDEK PARÇALAR SPARE PARTS					
	h	b	L	f		Baskı Parçası Clamp	Baskı Vidası Screw	Altlık Shim	Altlık Vidası Shim Screw	Pul Stamp	Anahtar Allen Key
TCZNN											
2020 K12	20	20	125	10	CNM.12 04..	TSK1	TSBV M6x30	BAX-CN12	TSAV M4X10	TSP 6,5X12	AA3
2525 M12	25	25	150	12.5							
3232 P12	32	32	170	16							
2525 M16	25	25	150	12.5	CNM.16 06..	TSK3	TSBV M6X30x7	BAX- CN16	TSAV M6X16	TSP 6,5X12	AA4
3232 P16	32	32	170	16							
4040 S16	40	40	250	20							
3232 P19	32	32	170	16	CNM 19 09..	TSK4	TSBV M8X30	BAX- CN19	TSAV M6X16		AA4
4040 P19	40	40	250	20							

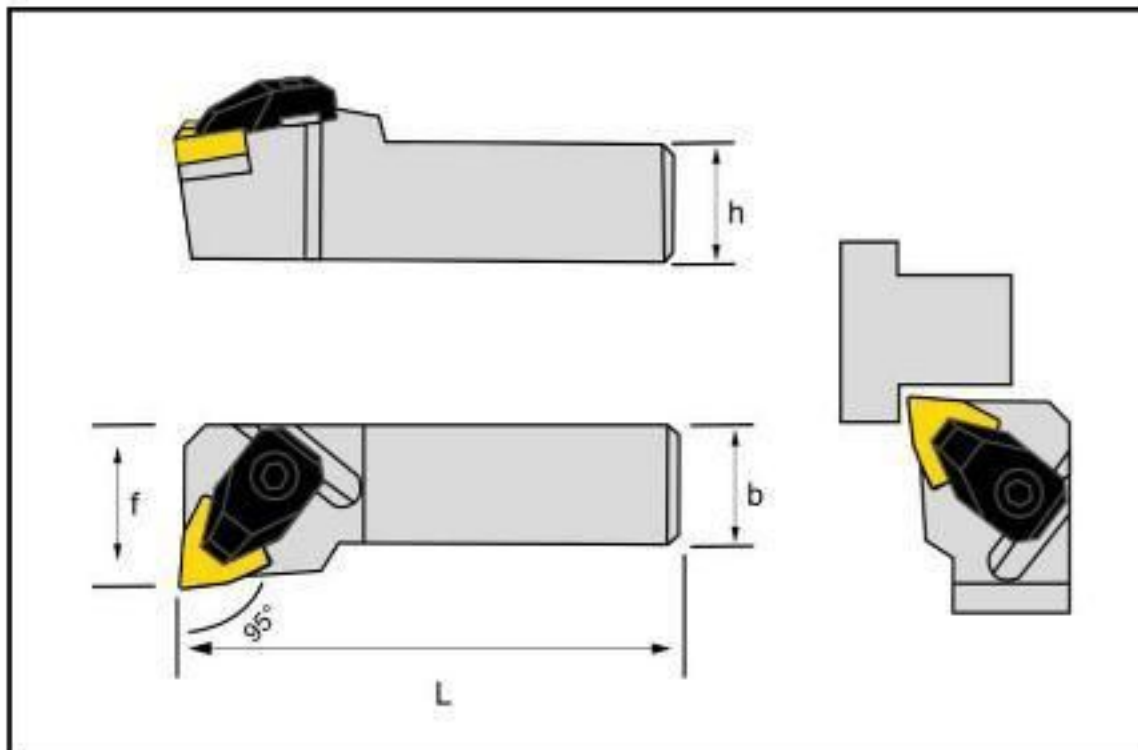

KOD CODE	ÖLÇÜLER DIMENSION (mm)				KESİCİ UÇ INSERT	YEDEK PARÇALAR SPARE PARTS					
	h	b	L	f		Baskı Parçası Clamp	Baskı Vidası Screw	Altlık Shim	Altlık Vidası Shim Screw	Pul Stamp	Anahtar Allen Key
TWLNR/L											
1616 H06	16	16	100	20	WNM.06 04..	TSK2	TSBV M5x23,5	-	-	TSP 6,5X12	AA3
2020 K06	20	20	125	25							
2525 M06	25	25	150	32							
2020 K08	20	20	125	25	WNM.08 04..	TSK1	TSBV M6x30	BAX- WN08	TSAV M4X10	TSP 6,5X12	AA3
2525 M08	25	25	150	32							
3232 P08	32	32	170	40							
4040 S08	40	40	250	50							

T SİSTEM DIŞ TORNA KATERLERİ T System External Lathe Tool Holders

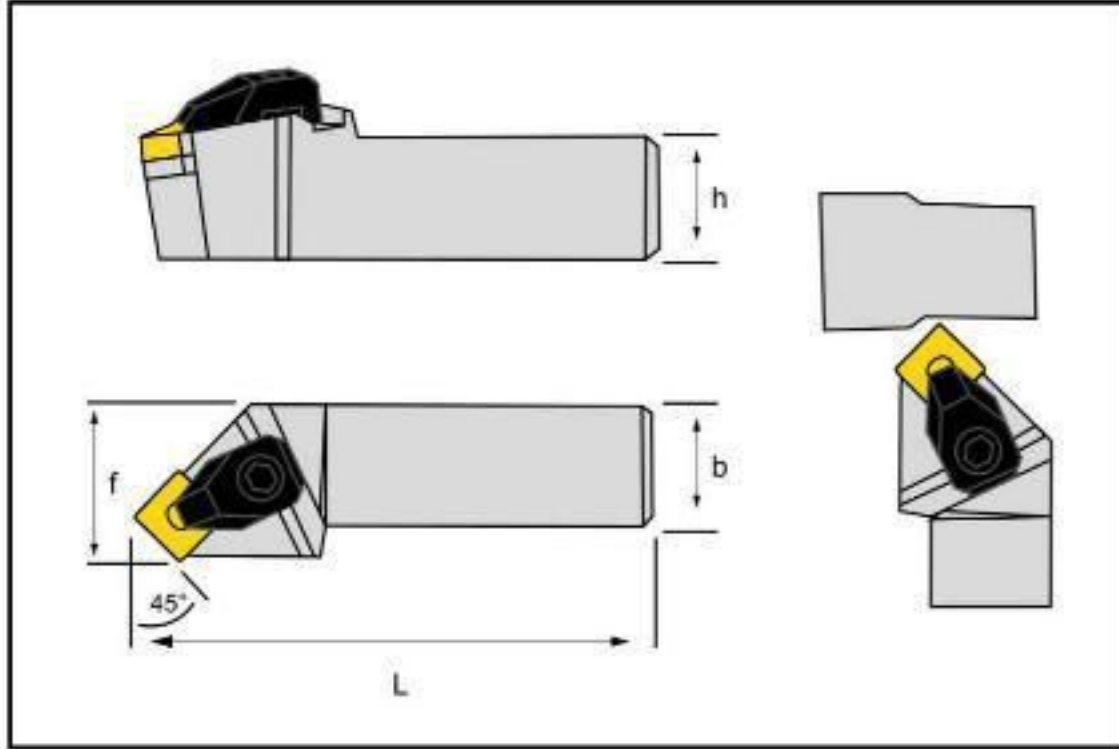

KOD CODE	ÖLÇÜLER DIMENSION (mm)				KESİCİ UÇ INSERT	YEDEK PARÇALAR SPARE PARTS					
	h	b	L	f		Baskı Parçası Clamp	Baskı Vidası Screw	Altık Shim	Altık Vidası Shim Screw	Pul Stamp	Anahtar Allen Key
TSSNR/L											
2020 K12	20	20	125	25	SNM.12 04..	TSK1	TSBV M6x30	BAX-SN12	TSAV M4X10	TSP 6,5X12	AA3
2525 M12	25	25	150	32							
3232 P12	32	32	170	40							
2525 M15	25	25	150	32	SNM.15 04..	TSK3	TSBV M6x30x7	BAX-SN15	TSAV M6X16	-	AA4
3232 P15	32	32	170	40							
4040 S15	32	32	250	50							
4040 S15	40	40	250	50							

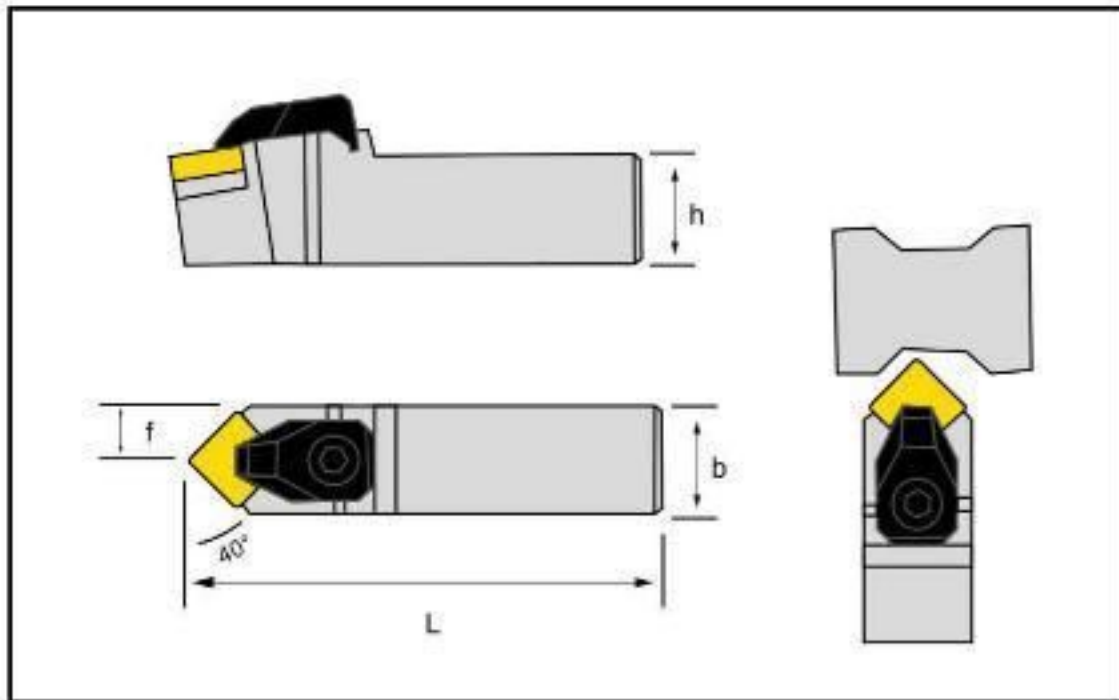

KOD CODE	ÖLÇÜLER DIMENSION (mm)				KESİCİ UÇ INSERT	YEDEK PARÇALAR SPARE PARTS					
	h	b	L	f		Baskı Parçası Clamp	Baskı Vidası Screw	Altık Shim	Altık Vidası Shim Screw	Pul Stamp	Anahtar Allen Key
TSDNN											
2020 K12	20	20	125	10	SNM.12 04..	TSK1	TSBV M6x30	BAX-SN12	TSAV M4X10	TSP 6,5X12	AA3
2525 M12	25	25	150	12.5							
3232 P12	32	32	170	16							
2525 M15	25	25	150	12.5	SNM.15 04..	TSK3	TSBV M6x30x7	BAX-SN15	TSAV M6X16	-	AA4
3232 P15	32	32	170	16							
4040 S15	32	32	250	20							
4040 S15	40	40	250	20							

T SİSTEM DIŞ TORNA KATERLERİ

T System External Lathe Tool Holders

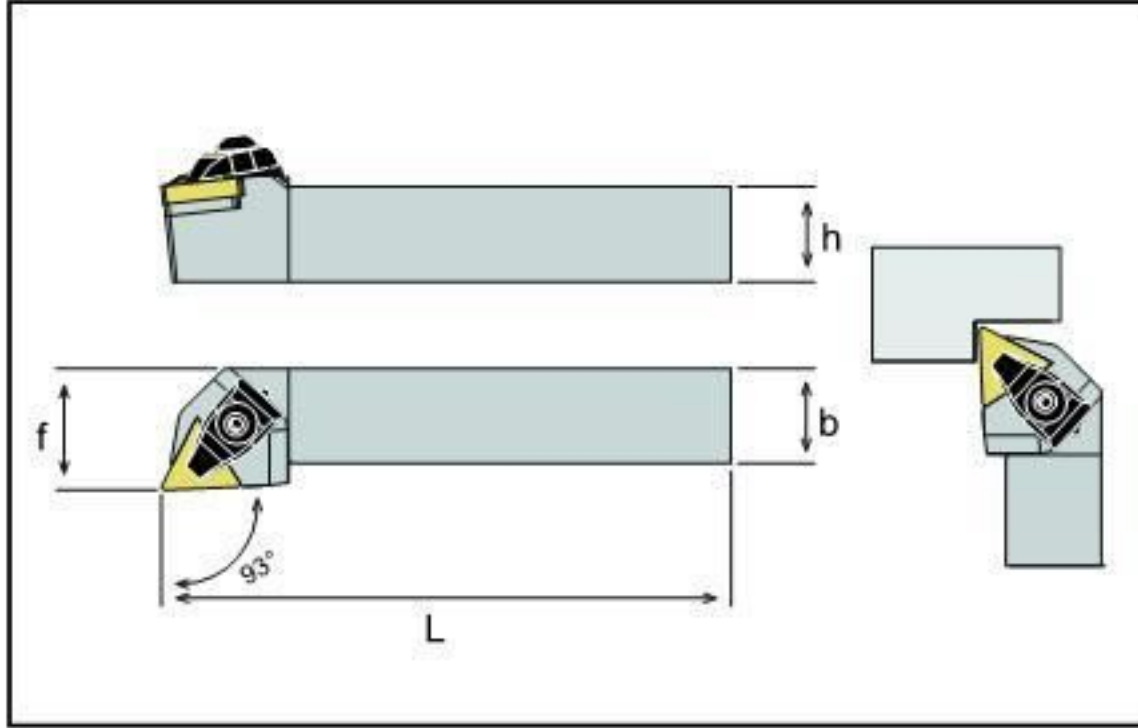

KOD CODE	ÖLÇÜLER DIMENSION (mm)				KESİCİ UÇ INSERT	YEDEK PARÇALAR SPARE PARTS					
	h	b	L	f		Baskı Parçası Clamp	Baskı Vidası Screw	Aitlik Shim	Aitlik Vidası Shim Screw	Pul Stamp	Anahtar Allen Key
TTJNR											
2020 K16	20	20	125	25	TNM. 16 04...	TSK2	TSBV M5x25	BAX-TN16	TSAV M4X10	TSP 6,5X12	AA3
2525 M16	25	25	150	32							
3232 P16	32	32	170	40							
2525 M22	25	25	150	32	TNM. 22 04	TSK1	TSBV M6x30	BAX-TN22	TSAV M4X10	TSP 6,5X12	AA3
3232 P22	32	32	170	40							
4040 S22	40	40	250	50							

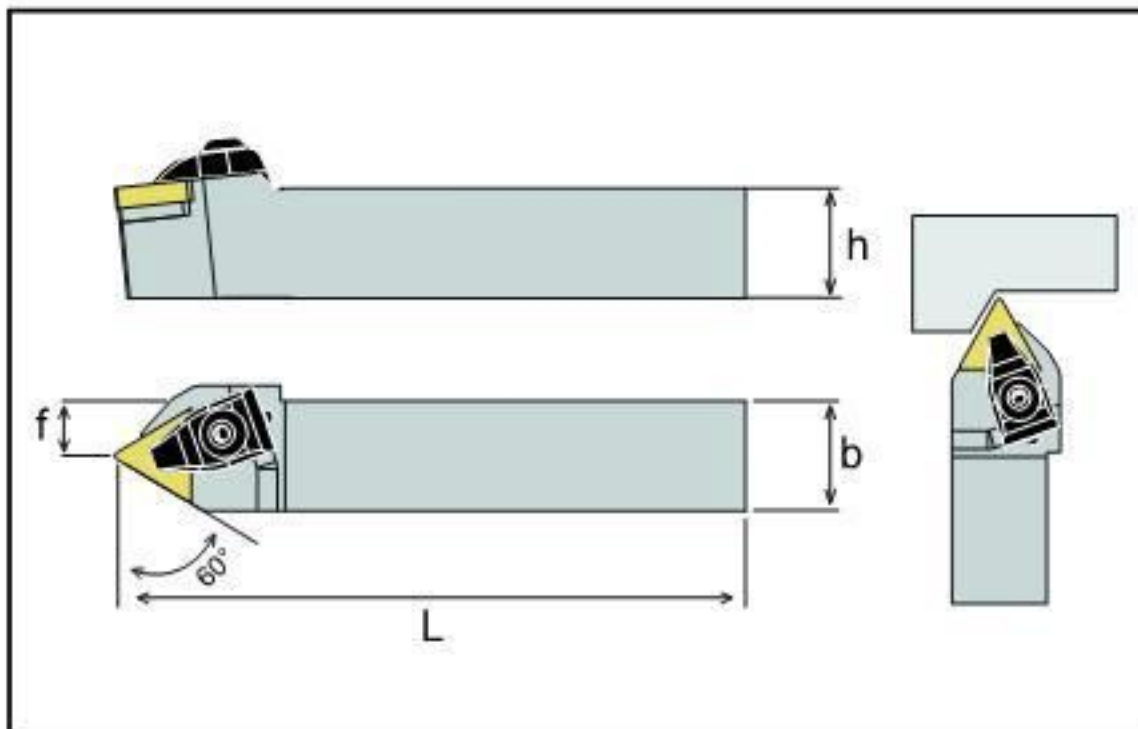

KOD CODE	ÖLÇÜLER DIMENSION (mm)				KESİCİ UÇ INSERT	YEDEK PARÇALAR SPARE PARTS					
	h	b	L	f		Baskı Parçası Clamp	Baskı Vidası Screw	Aitlik Shim	Aitlik Vidası Shim Screw	Pul Stamp	Anahtar Allen Key
TTENN											
2020 K16	20	20	125	10	TNM. 16 04..	TSK2	TSBV M5x25	BAX-TN16	TSAV M4X10	TSP 6,5X12	AA3
2525 M16	25	25	150	12,5							
3232 P16	32	32	170	16							
2525 M22	25	25	150	12,5	TNM. 22 04	TSK1	TSBV M6x30	BAX-TN22	TSAV M4X10	TSP 6,5X12	AA3
3232 P22	32	32	170	16							
4040 S22	40	40	250	20							

T SİSTEM DIŞ TORNA KATERLERİ T System External Lathe Tool Holders

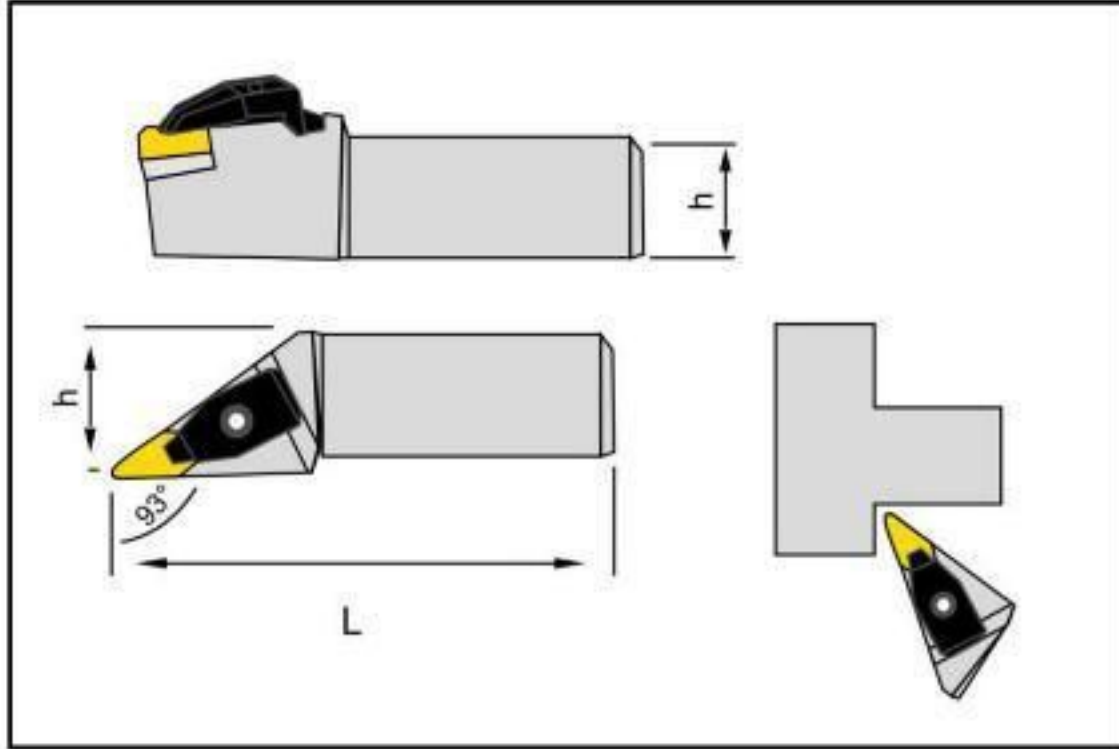



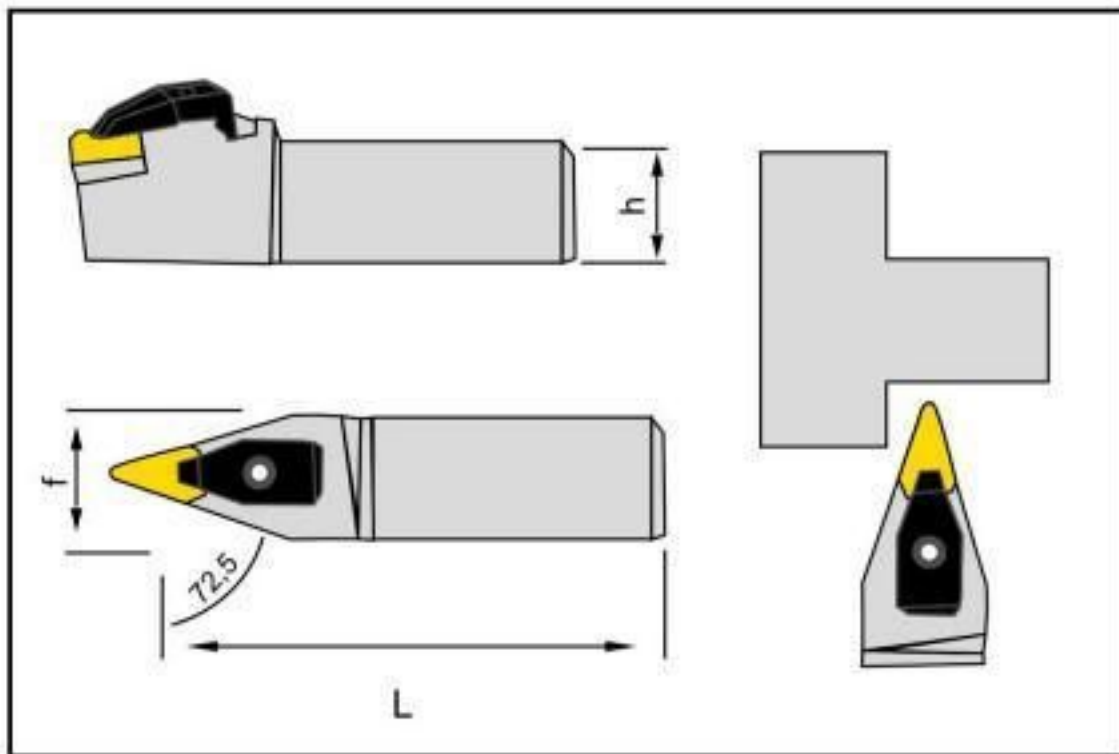

KOD CODE	ÖLÇÜLER DIMENSION (mm)				KESİCİ UÇ INSERT	YEDEK PARÇALAR SPARE PARTS					
	h	b	L	f		Baskı Parçası Clamp	Baskı Vidası Screw	Altık Shim	Altık Vidası Shim Screw	Pul Stamp	Anahtar Allen Key
TVJNR											
2020 K16	20	20	125	25	VNM.16 04..	TSK5	TSBV M6x30	BAX-VN16	TSAV M4X10	TSP 6.5X12	AA3
2525 M16	25	25	150	32							
3232 P16	32	32	170	40							

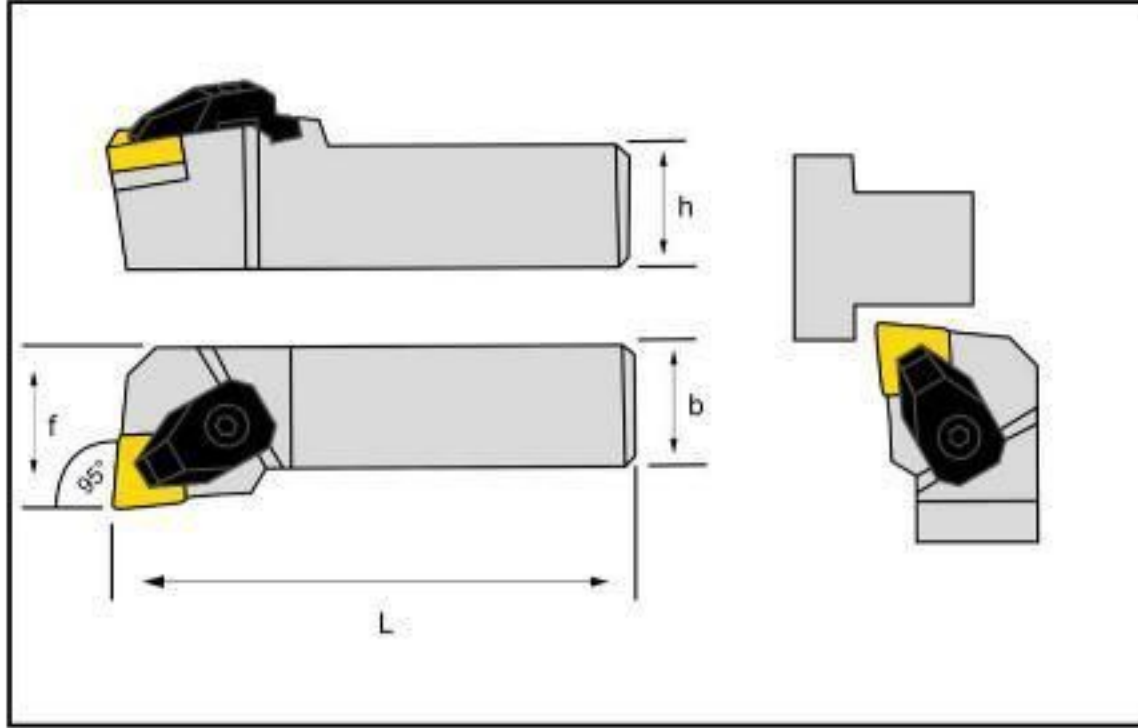

KOD CODE	ÖLÇÜLER DIMENSION (mm)				KESİCİ UÇ INSERT	YEDEK PARÇALAR SPARE PARTS					
	h	b	L	f		Baskı Parçası Clamp	Baskı Vidası Screw	Altık Shim	Altık Vidası Shim Screw	Pul Stamp	Anahtar Allen Key
TVVNN											
2020 K16	20	20	125	10	VNM.16 04..	TSK5	TSBV M6x30	BAX-VN16	TSAV M4X10	TSP 6.5X12	AA3
2525 M16	25	25	150	12,5							
3232 P16	32	32	170	16							

T SİSTEM DIŞ TORNA KATERLERİ T System External Lathe Tool Holders



KOD CODE	ÖLÇÜLER DIMENSION (mm)				KESİCİ UÇ INSERT	YEDEK PARÇALAR SPARE PARTS					
	h	b	L	f		Baskı Parçası Clamp	Baskı Vidası Screw	Altlık Shim	Altlık Vidası Shim Screw	Pul Stamp	Anahtar Allen Key
TSKNR/L											
2020 K12	20	20	125	25	SNM.12 04..	TSK1	TSBV M6x30	BAX-SN12	TSAV M4X10	TSP 6,5X1	AA3
2525 M12	25	25	150	32							
3232 P12	32	32	170	40							
3232 P15	32	32	170	40	SNMG.15 08..	TSK3	TSBV M6x30X7	BAX-SN15	TSAV M6x16	-	AA4

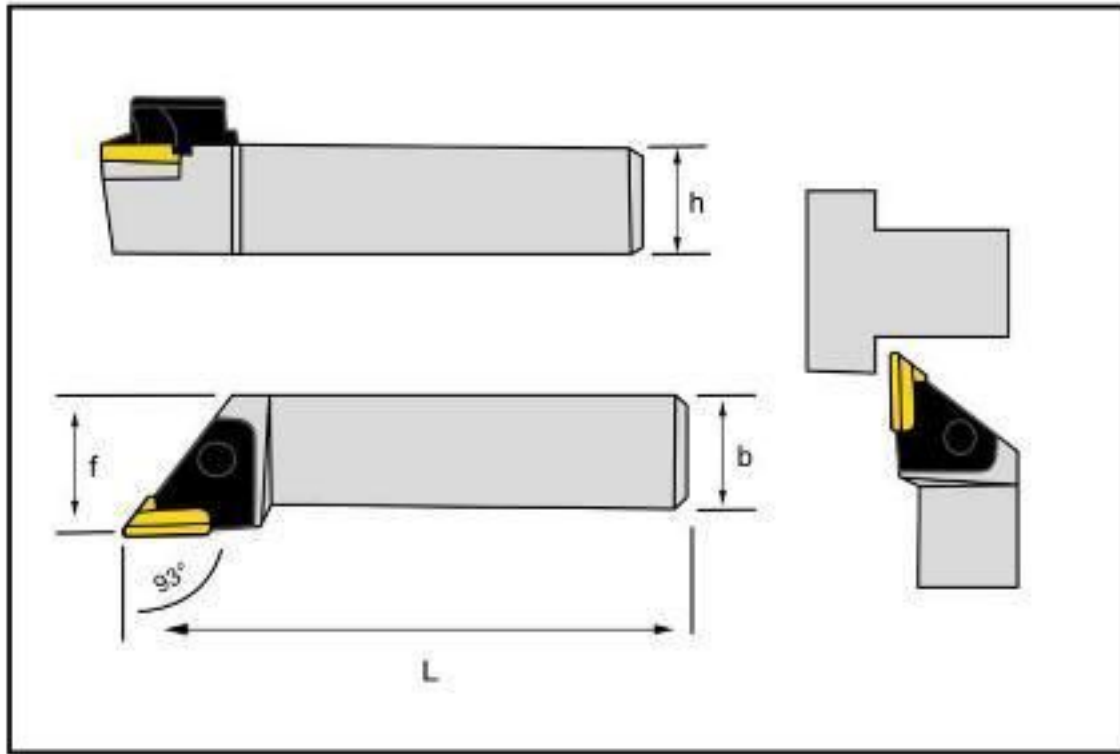

KOD CODE	ÖLÇÜLER DIMENSION (mm)				KESİCİ UÇ INSERT	YEDEK PARÇALAR SPARE PARTS					
	h	b	L	f		Baskı Parçası Clamp	Baskı Vidası Screw	Altlık Shim	Altlık Vidası Shim Screw	Yay Spring	Anahtar Allen Key
CKJNR/L											
2020 K16	20	20	125	25	KNUX-16 04..	CSK/R CSK/L	CSBV-1 M6x30	BAX- KN16-R/L	CSAV M3X10	BAX-Y	AA5
2525 M16	25	25	150	32							
3232 P16	32	32	170	40							



M SİSTEM DIŞ TORNA KATERLERİ

M SYSTEM EXTERNAL LATHE TOOLHOLDERS



M SİSTEM DIŞ TORNA KATERLERİ

M System External Lathe Tool Holders

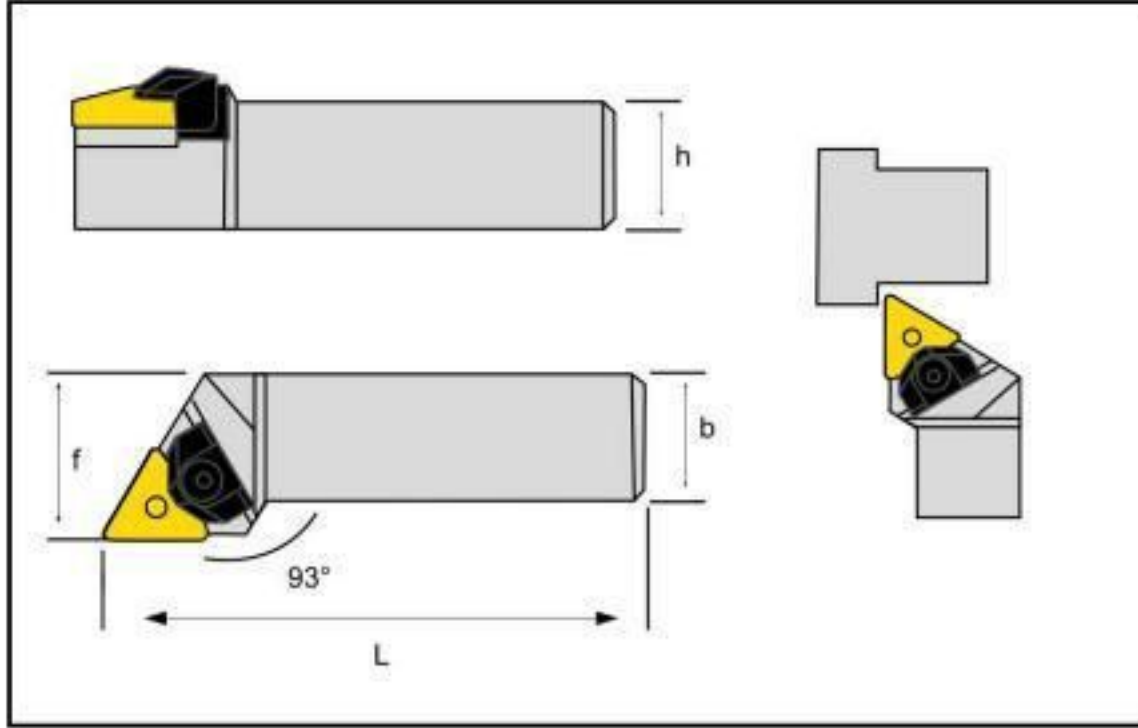

KOD CODE	ÖLÇÜLER DIMENSION (mm)				KESİCİ UÇ INSERT	YEDEK PARÇALAR SPARE PARTS					
	h	b	L	f		Baskı Parçası Clamp	Baskı Vidası Screw	Altık Shim	Pim Pin	Pul Stamp	Anahtar Allen Key
MTJNR/L											
2020 K16	20	20	125	25	TNM.16 04..	MSK-1	TSBV M6x30	BAX-TN16	BPM1 3,70x5	TSP 6,5X12	AA3
2525 M16	25	25	150	32							
3232 P16	32	32	170	40							
2525 M22	25	25	150	32	TNM.22 04..	MSK-1	TSBV M6x30	BAX-TN22	BPM2 6x5	TSP 6,5X12	AA3
3232 P22	32	32	170	40							
4040 S22	40	40	250	50							

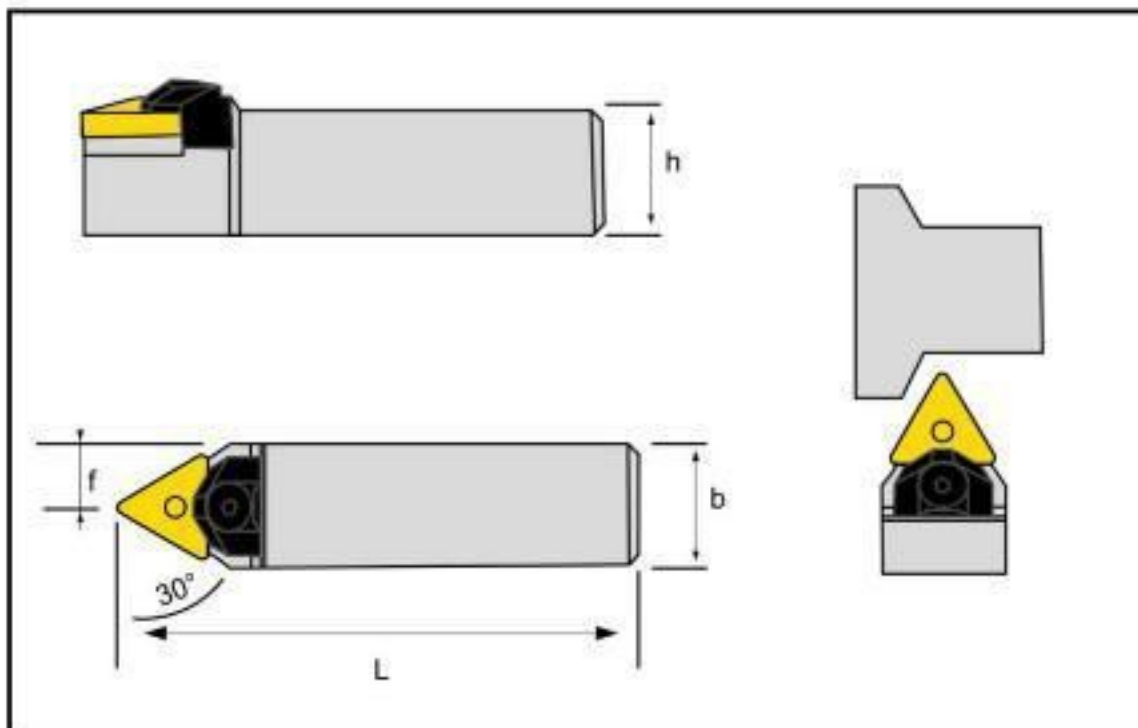

KOD CODE	ÖLÇÜLER DIMENSION (mm)				KESİCİ UÇ INSERT	YEDEK PARÇALAR SPARE PARTS					
	h	b	L	f		Baskı Parçası Clamp	Baskı Vidası Screw	Altık Shim	Pim Pin	Pul Stamp	Anahtar Allen Key
MTENN											
2020 K16	20	20	125	10	TNM.16 04..	MSK-1	TSBV M6x30	BAX-TN16	BPM1 3,70x5	TSP 6,5X12	AA3
2525 M16	25	25	150	12,5							
3232 P16	32	32	170	16							
2525 M22	25	25	150	12,5	TNM.22 04..	MSK-1	TSBV M6x30	BAX-TN22	BPM2 5x6	TSP 6,5X12	AA3
3232 P22	32	32	170	16							
4040 S22	40	40	250	20							

M SİSTEM DIŞ TORNA KATERLERİ

M System External Lathe Tool Holders

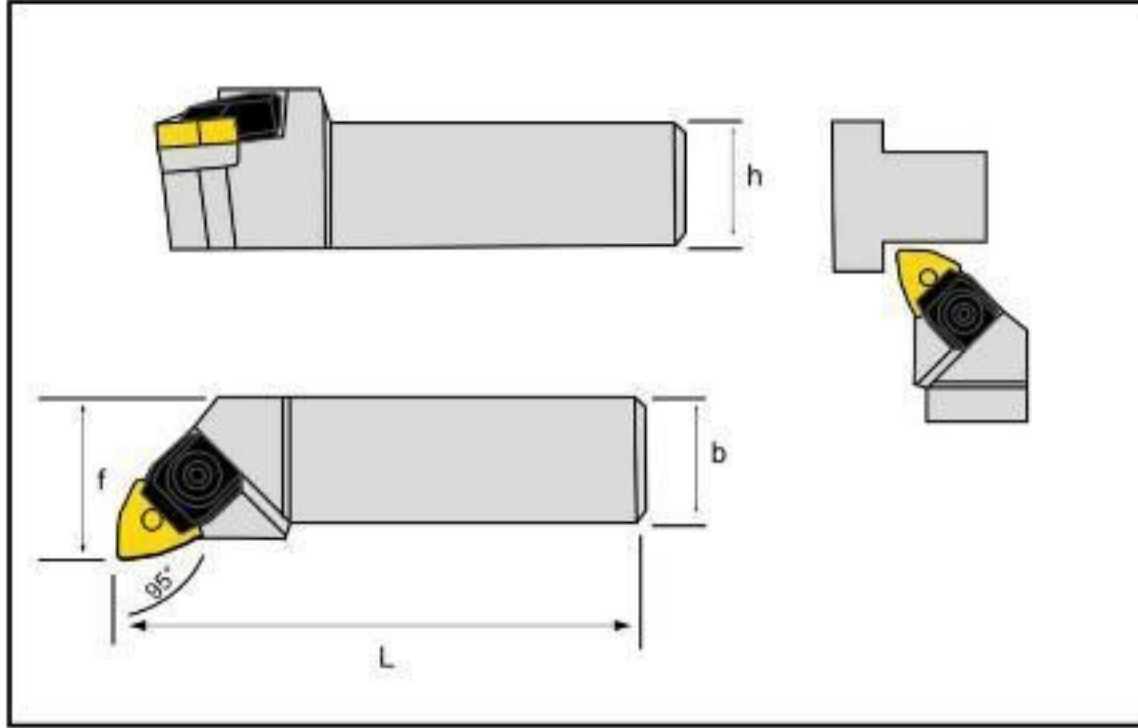

KOD CODE	ÖLÇÜLER DIMENSION (mm)				KESİCİ UÇ INSERT	YEDEK PARÇALAR SPARE PARTS					
	h	b	L	f		Baskı Parçası Clamp	Baskı Vidası Screw	Altık Shim	Pim Pin	Yay Spring	Anahtar Allen Key
MWLNR / L											
1616 H06*	16	16	100	20	WNM.06 04..	MSK-4	MSBV M5x25		BPM1 3,70x5		AA3
2020 K06*	20	20	125	25							
2525 M06*	25	25	150	32							
2020 K08	20	20	125	25	WNM.08 04..	MSK-3	MSBV M6x30	BAX-WN08	BPM3 5x6	TSP 6,5X12	AA3
2525 M08	25	25	150	32							
3232 P08	32	32	170	40							
* ALTLIKSIZ											

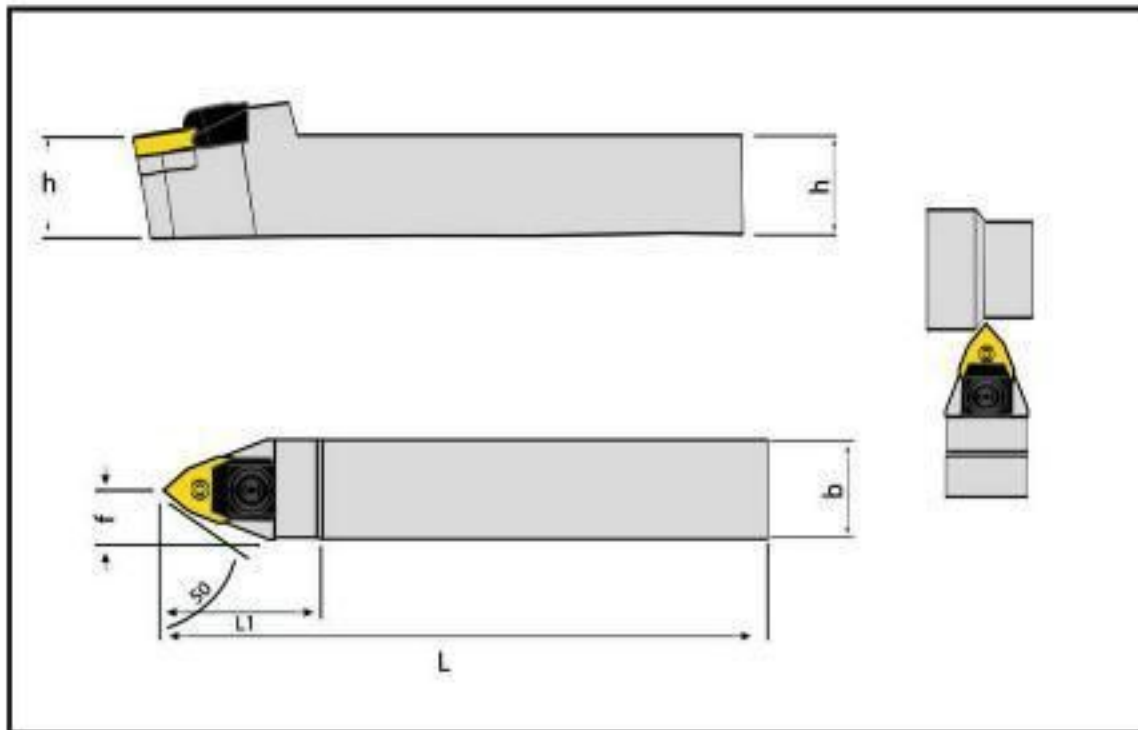

KOD CODE	ÖLÇÜLER DIMENSION (mm)				KESİCİ UÇ INSERT	YEDEK PARÇALAR SPARE PARTS					
	h	b	L	f		Baskı Parçası Clamp	Baskı Vidası Screw	Altık Shim	Pim Pin	Yay Spring	Anahtar Allen Key
MWDNN											
1616 H06*	16	16	100	8	WNM.06 04..	MSK-4	MSBV M5x25		BPM1 3,70x5		AA3
2020 K06*	20	20	125	10							
2525 M06*	25	25	150	12,5							
2020 K08	20	20	125	10	WNM.08 04..	MSK-3	MSBV M6x30	BAX-WN08	BPM3 5x6	TSP 6,5X12	AA3
2525 M08	25	25	150	12,5							
3232 P08	32	32	170	16							
* ALTLIKSIZ											



S SYSTEM DIŞ TORMA KATERLERİ

S SYSTEM EXTERNAL LATHE TOOL HOLDERS

S SİSTEM DIŞ TORNA KATERLERİ

S System External Lathe Tool Holders

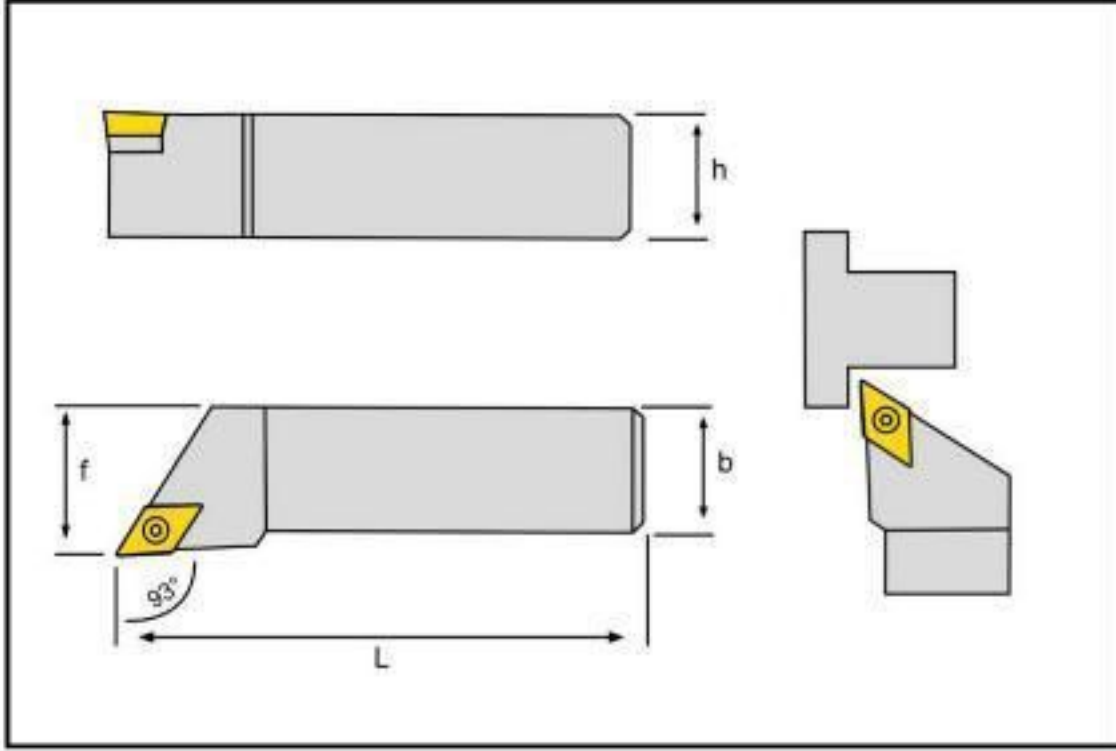



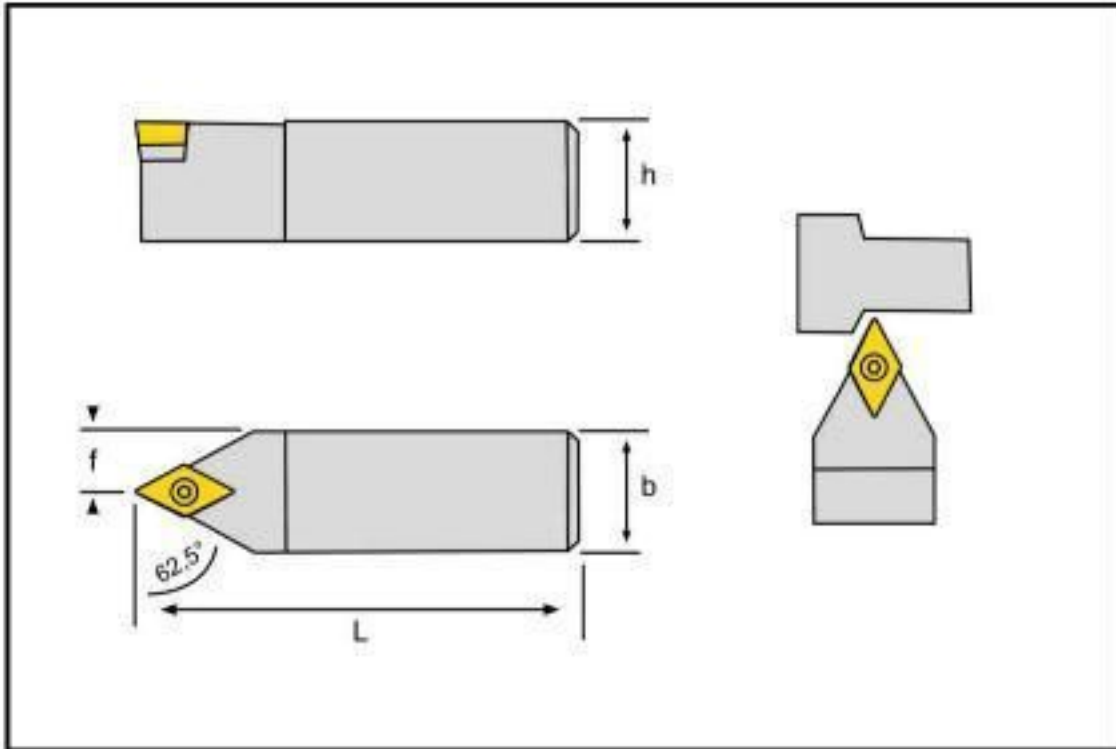



KOD CODE	ÖLÇÜLER DIMENSION (mm)				KESİCİ UÇ INSERT	YEDEK PARÇALAR SPARE PARTS			
	h	b	L	f		Sıkma Vidası Clamp Screw	Altlık Shim	Altlık Vidası Shim Screw	Anahtar Torx Key
SDJCR/L	h	b	L	f					
0808 E07	08	08	70	10	DCM 07 02.	BSSV M2,5X7			T08
1010 E07	10	10	70	12					
1212 F07	12	12	80	16					
1616 H07	16	16	100	20					
1616 H11	16	16	100	20	DCM 11 T3..	BSSV M3,5X14	BAX- DC11	SBV-M5.05 A3,5x11	T15
2020 K11	20	20	125	25					
2525 M11	25	25	150	32					
3232 P11	32	32	170	40					

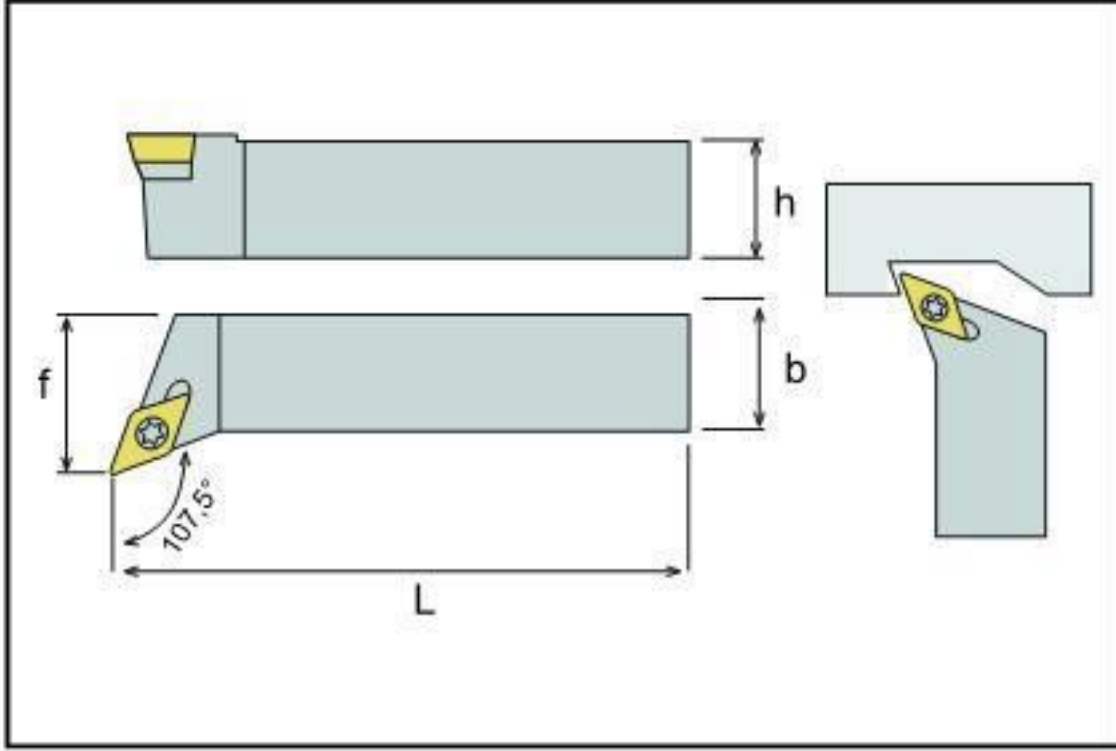

KOD CODE	ÖLÇÜLER DIMENSION (mm)				KESİCİ UÇ INSERT	YEDEK PARÇALAR SPARE PARTS			
	h	b	L	f		Sıkma Vidası Clamp Screw	Altlık Shim	Altlık Vidası Shim Screw	Anahtar Torx Key
SDNCN	h	b	L	f					
0808 E07	08	08	70	04	DCM 07 02.	BSSV M2,5X7			T08
1010 E07	10	10	70	05					
1212 F07	12	12	80	06					
1616 H07	16	16	100	08					
1616 H11	16	16	100	08	DCM 11 T3..	BSSV M3,5X14	BAX- DC11	SBV-M5.05 A3,5x11	T15
2020 K11	20	20	125	10					
2525 M11	25	25	150	12,5					
3232 P11	32	32	170	16					

S SİSTEM DIŞ TORNA KATERLERİ S System External Lathe Tool Holders



KOD CODE	ÖLÇÜLER DIMENSION (mm)				KESİCİ UÇ INSERT	YEDEK PARÇALAR SPARE PARTS			
	h	b	L	f		Sıkma Vidası Clamp Screw	Altlık Shim	Altlık Vidası Shim Screw	Anahtar Torx Key
SDHCR/L	h	b	L	f					
0808 E07	08	08	70	10	DCM 07 02..	BSSV M2,5X7			T08
1010 E07	10	10	70	12					
1212 F07	12	12	80	16					
1616 H07	16	16	100	20					
1616 H11	16	16	100	20	DCM 11 T3..	BSSV M3,5X14	BAX- DC11	SBV-M5.05 A3,5x11	T15
2020 K11	20	20	125	25					
2525 M11	25	25	150	32					
3232 P11	32	32	170	40					

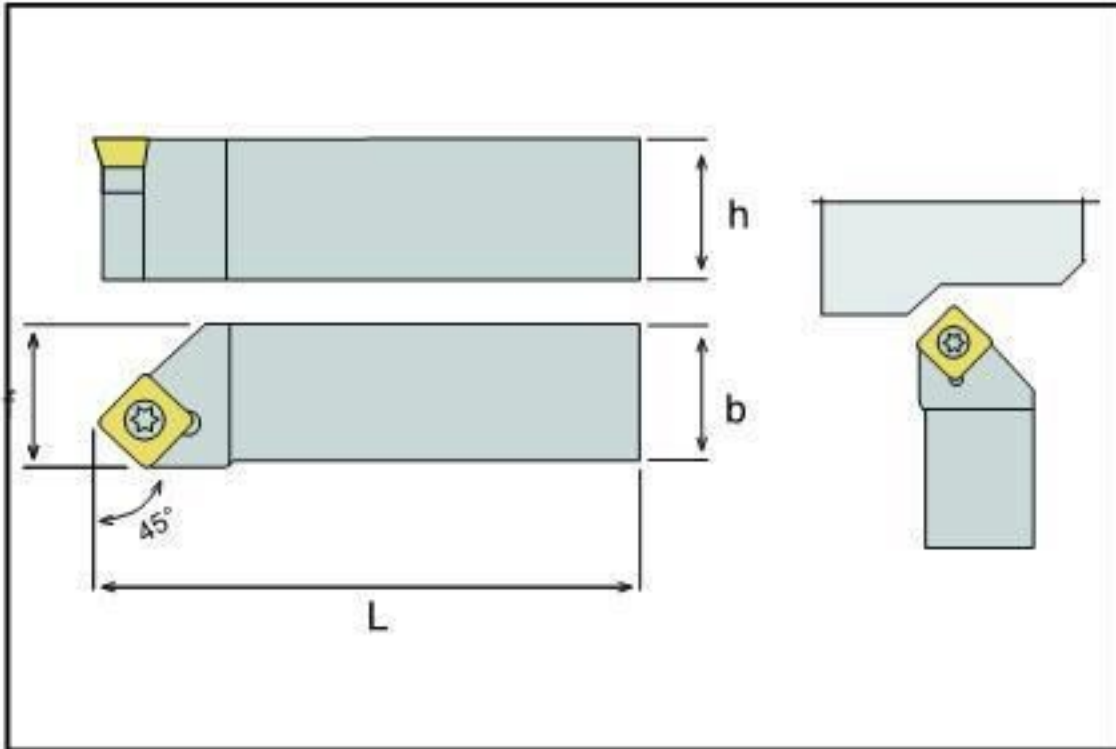

KOD CODE	ÖLÇÜLER DIMENSION (mm)				KESİCİ UÇ INSERT	YEDEK PARÇALAR SPARE PARTS			
	h	b	L	f		Sıkma Vidası Clamp Screw	Altlık Shim	Altlık Vidası Shim Screw	Anahtar Torx Key
SSSCR/L	h	b	L	f					
1212 F09	12	12	80	16	SCM.09 T3..	BSSV M3,5X9			T15
1616H09	16	16	100	20					
2020K09	20	20	125	25					
1616 H12	16	16	100	20	SCM. 12 04..	SSV M4.5X16	BAX SC12	SBV-M7.05 A4,5x11	T20
2020 K12	20	20	125	25					
2525 M12	25	25	150	32					

S SİSTEM DIŞ TORNA KATERLERİ

S System External Lathe Tool Holders

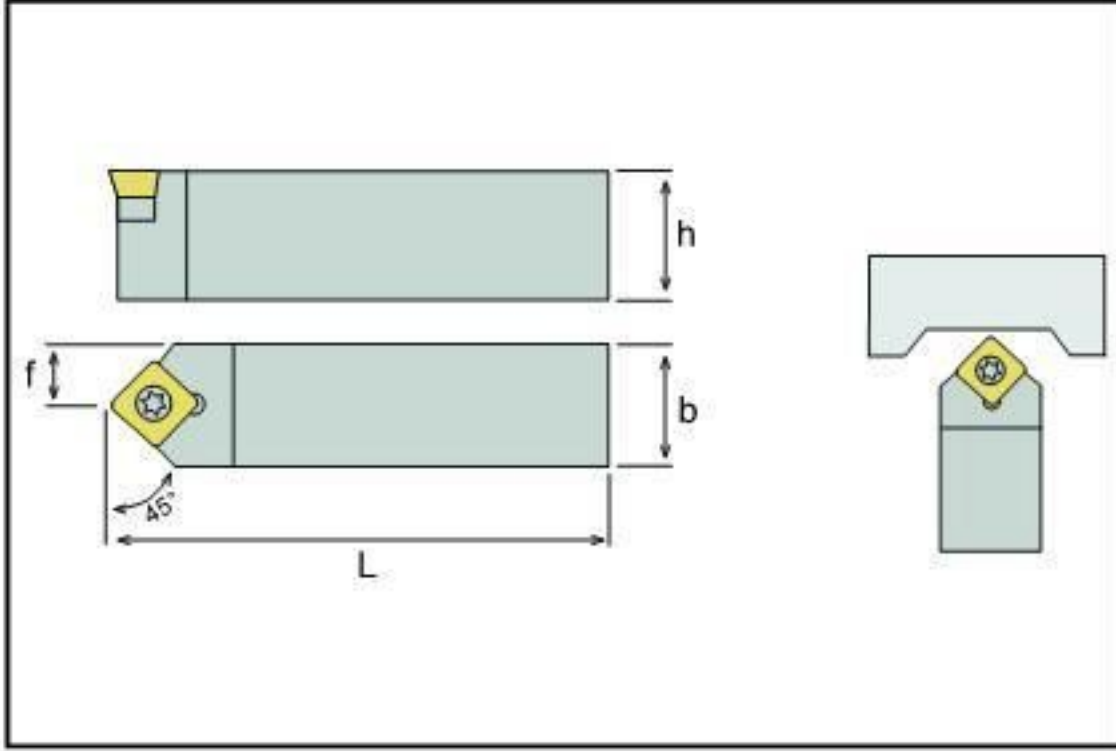

KOD CODE	ÖLÇÜLER DIMENSION (mm)				KESİCİ UÇ INSERT	YEDEK PARÇALAR SPARE PARTS			
	h	b	L	f		Sıkma Vidası Clamp Screw	Altlık Shim	Altlık Vidası Shim Screw	Anahtar Torx Key
SSDCN									
1212 F09	12	12	80	6	SCM.09 T3..	BSSV M3,5X9			T15
1616H09	16	16	100	8		BSSV M3,5X14	BAX- SC09	SBV-M5.05 A3,5x11	T15
2020K09	20	20	125	10					
1616 H12	16	16	100	8	SCM. 12 04..	SSV M4,5X16	BAX SC12	SBV-M7.05 A4,5x11	T20
2020 K12	20	20	125	10					
2525 M12	25	25	150	12,5					

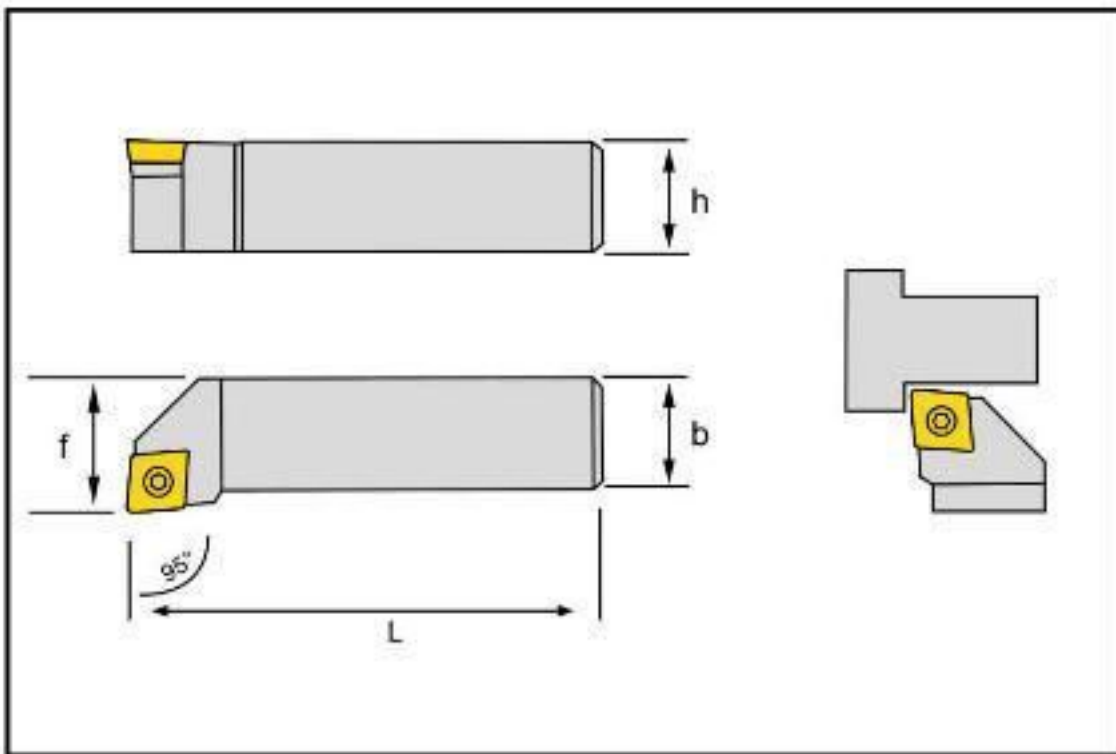

KOD CODE	ÖLÇÜLER DIMENSION (mm)				KESİCİ UÇ INSERT	YEDEK PARÇALAR SPARE PARTS			
	h	b	L	f		Sıkma Vidası Clamp Screw	Altlık Shim	Altlık Vidası Shim Screw	Anahtar Torx Key
SCLCR/L									
0808 E06	8	8	70	10	CCM.06 02..	SSV M2,5x7	-	-	T08
1010 E06	10	10	70	12					
1212 F09	12	12	80	16	CCM.09 T3	SSV M3,5X9	-	-	T15
1616 H09	16	16	100	20		SSV M3,5X14	BAX- CC09	SBV-M5.05 A3,5x11	
2020 K09	20	20	125	25					
2020 K12	20	20	125	25	CCM.12 04	SSV M4,5X16	BAX- CC12	SBV-M7.05 A4.5x11	T15
2525 M12	25	25	150	32					

S SİSTEM DIŞ TORNA KATERLERİ

S System External Lathe Tool Holders

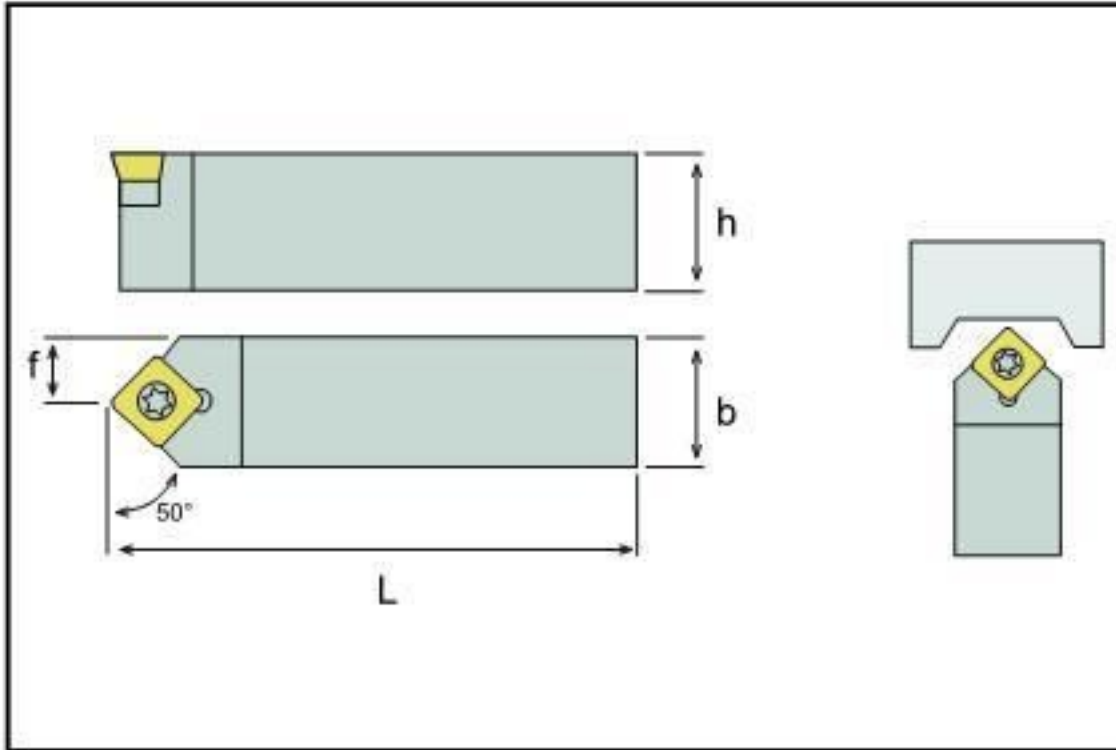

KOD CODE	ÖLÇÜLER DIMENSION (mm)				KESİCİ UÇ INSERT	YEDEK PARÇALAR SPARE PARTS			
	h	b	L	f		Sıkma Vidası Clamp Screw	Altık Shim	Altık Vidası Shim Screw	Anahtar Torx Key
SCMCN									
0808 E06	08	08	70	04	CCM.06 02..	SSV M2,5x7,5	-	-	T08
1010 E06	10	10	70	05		SSV M3,5X9	-	-	T15
1212 F09	12	12	80	06	CCM.09 T3	SSV M3,5x14	BAX- CC09	SBV-M5.05 A3,5x11	
1616 H09	16	16	100	08		SSV M4,5X16	BAX- CC12	SBV-M7.05 A4,5X11	T15
2020 K09	20	20	125	10	CCM.12 04				
2020 K12	20	20	125	10					
2525 M12	25	25	150	12,5					

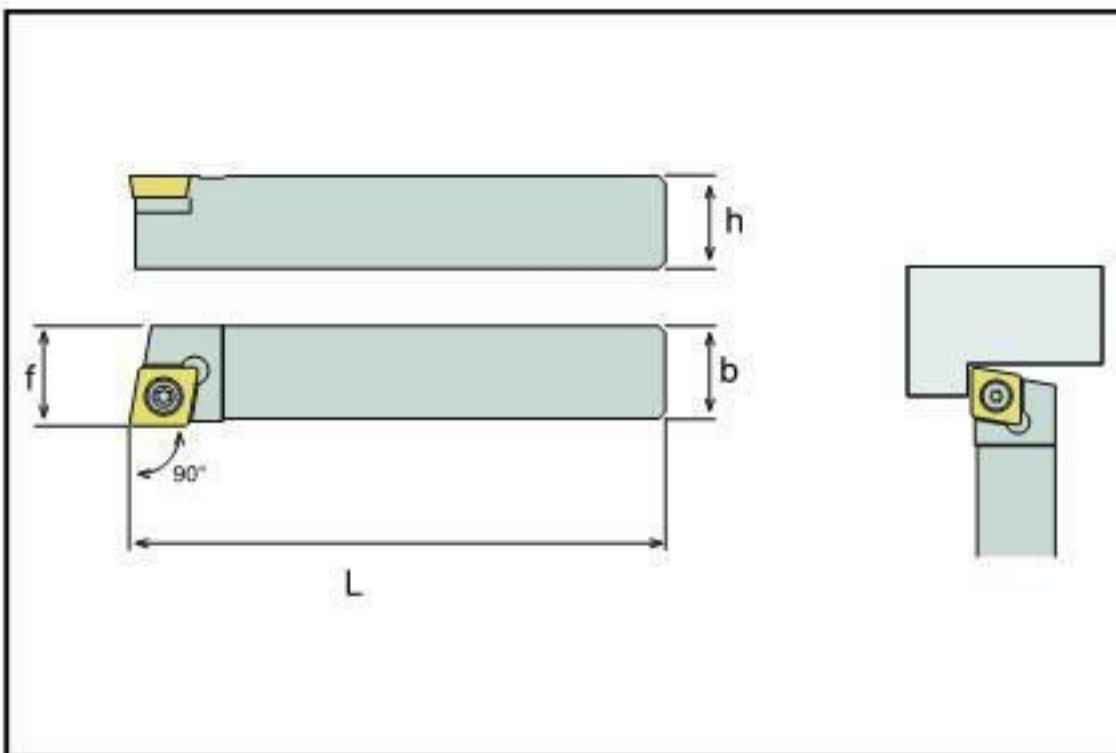

KOD CODE	ÖLÇÜLER DIMENSION (mm)				KESİCİ UÇ INSERT	YEDEK PARÇALAR SPARE PARTS			
	h	b	L	f		Sıkma Vidası	Altık Shim	Altık Vidası Shim Screw	Anahtar Allen Key
SCACR/L									
0808 E06	08	08	70	10	CCM.06 02..	SSV M2,5x7,5	-	-	T08
1010 E06	10	10	70	12		SSV M3,5X11	-	-	T15
1212 F09	12	12	80	16	CCM.09 T3	SSV M3,5x14	BAX- CC09	SBV-M5.05 A3,5x11	
1616 H09	16	16	100	20		SSV M4,5X16	BAX- CC12	SBV-M7.05 A4,5X11	T15
2020 K09	20	20	125	25	CCM.12 04				
2020 K12	20	20	125	25					
2525 M12	25	25	150	32					

S SİSTEM DIŞ TORNA KATERLERİ

S System External Lathe Tool Holders

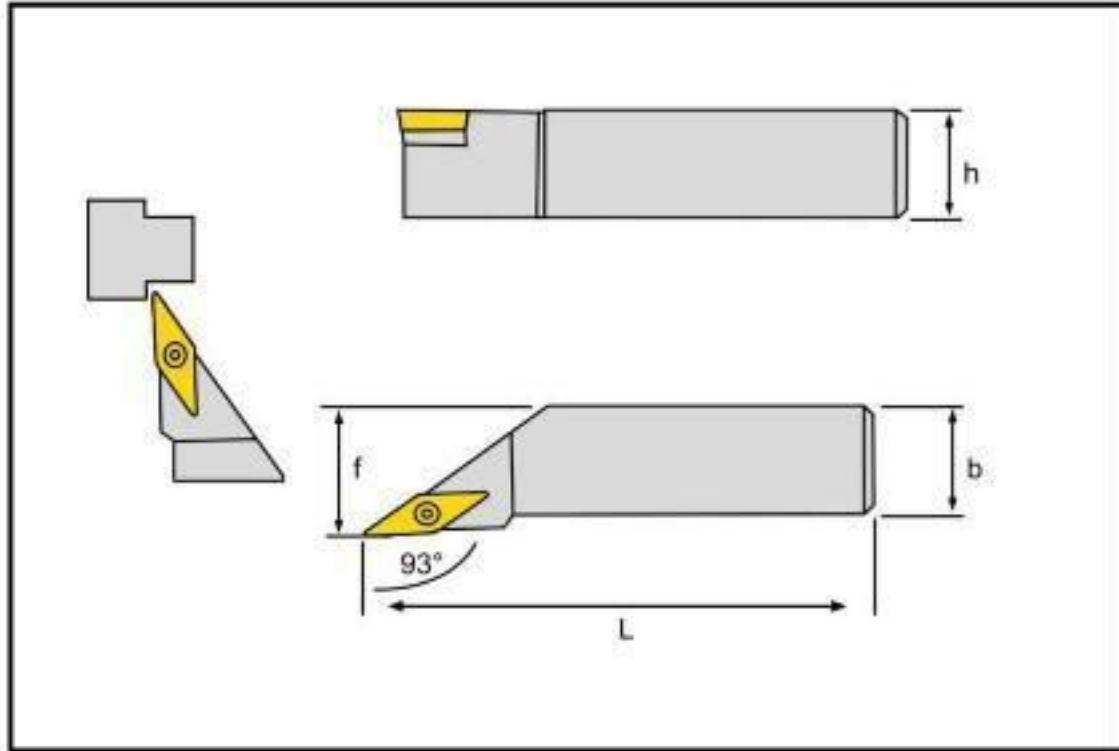



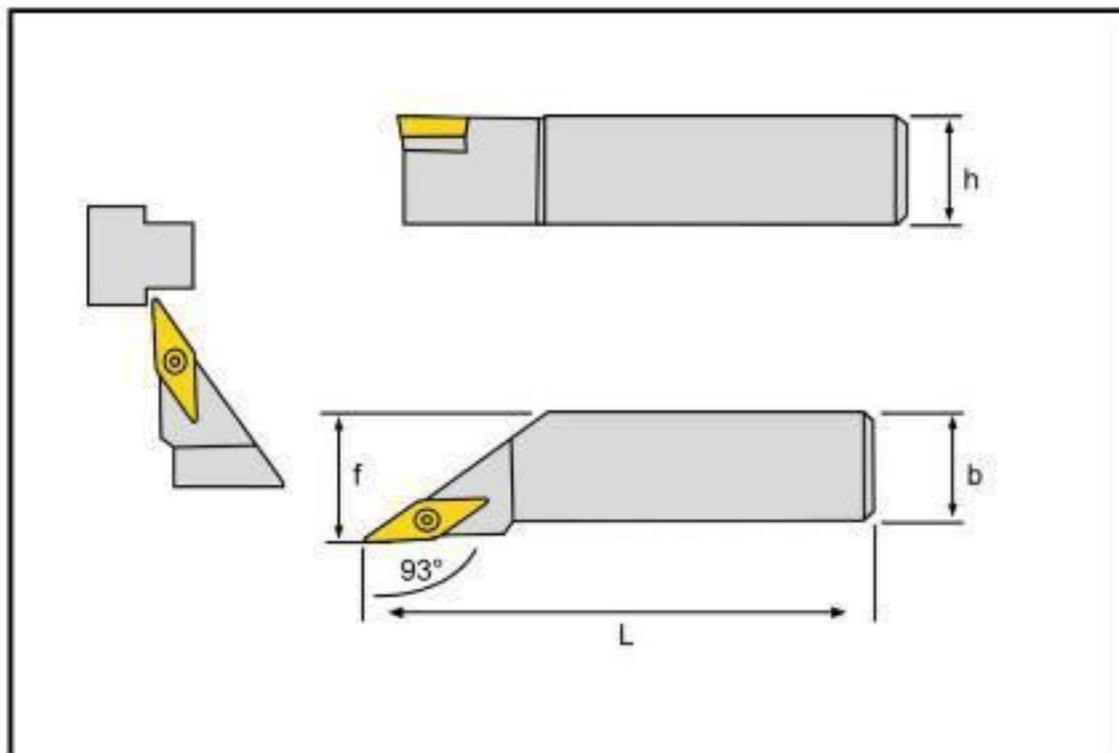



KOD CODE	ÖLÇÜLER DIMENSION (mm)				KESİCİ UÇ INSERT	YEDEK PARÇALAR SPARE PARTS			
	h	b	L	f		Sıkma Vidası Clamp Screw	Altk Shim	Altk Vidası Shim Screw	Anahtar Torx Key
SVJBR/L									
1616 H11	16	16	100	20	VBM.11 03..	SSV M2,5X7,5	-	-	T08
2020 K11	20	20	125	25					
2525 M11	25	25	150	32					
1616 H16	16	16	100	20	VBM.16 04..	SSV M3,5X14	BAX- VB16	SBV-M5.05 A-3,5	T15
2020 K16	20	20	125	25					
2525 M16	25	25	150	32					
3232 P16	32	32	170	40					

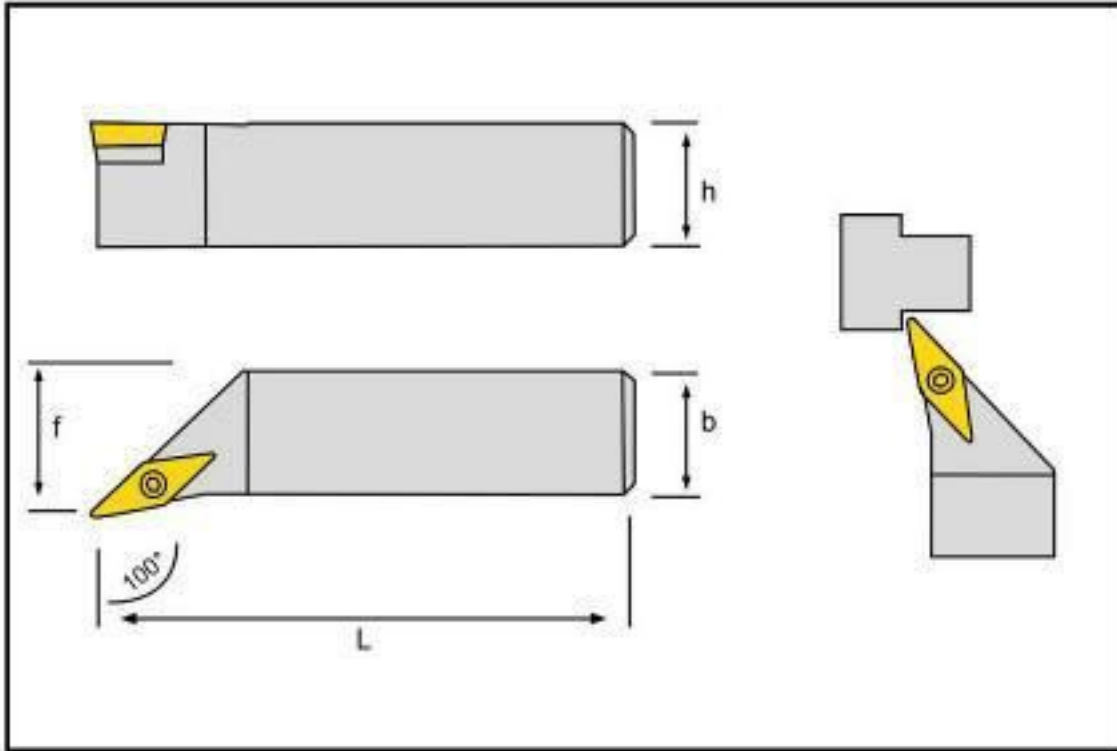





KOD CODE	ÖLÇÜLER DIMENSION (mm)				KESİCİ UÇ INSERT	YEDEK PARÇALAR SPARE PARTS			
	h	b	L	f		Sıkma Vidası Clamp Screw	Altk Shim	Altk Vidası Shim Screw	Anahtar Torx Key
SVVBN									
1616 H11	16	16	100	08	VBM.11 03..	SSV M2,5X7,5	-	-	T08
2020 K11	20	20	125	10					
2525 M11	25	25	150	12,5					
1616 H16	16	16	100	08	VBM.16 04..	SSV M3,5X14	BAX- VB16	SBV-M5.05 A-3,5	T15
2020 K16	20	20	125	10					
2525 M16	25	25	150	12,5					
3232 P16	32	32	170	16					

S SİSTEM DIŞ TORNA KATERLERİ S System External Lathe Tool Holders

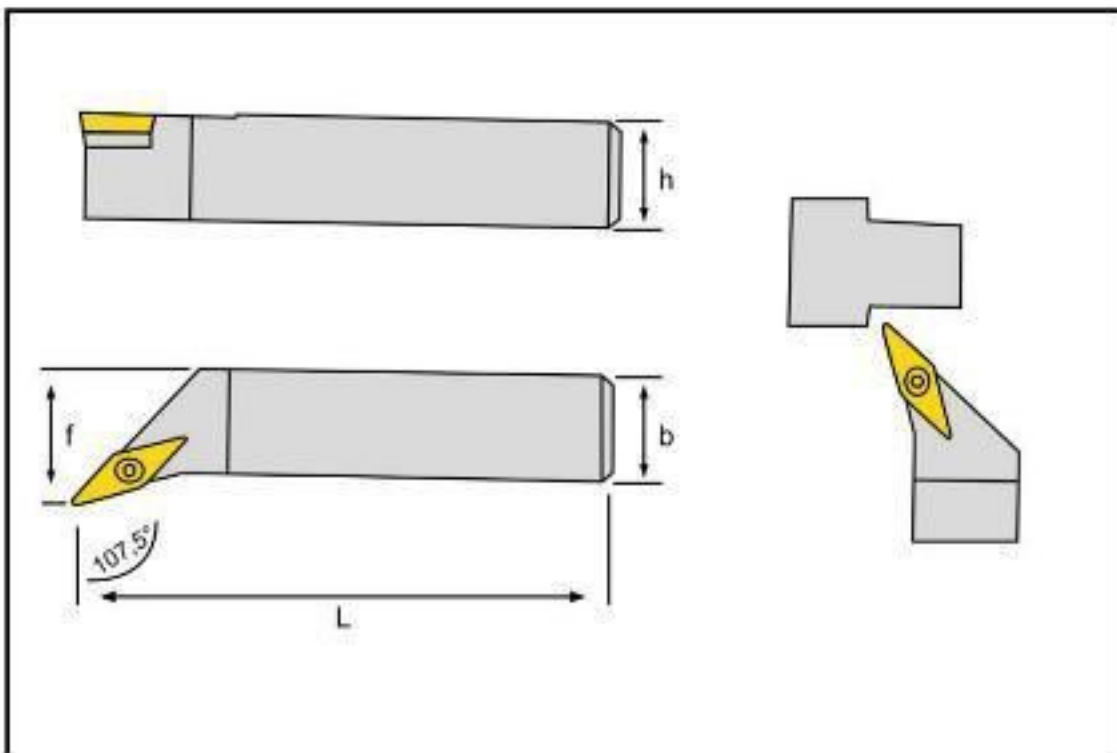

KOD CODE	ÖLÇÜLER DIMENSION (mm)				KESİCİ UÇ INSERT	YEDEK PARÇALAR SPARE PARTS			
	h	b	L	f		Sıkma Vidası Clamp Screw	Altık Shim	Altık Vidası Shim Screw	Anahtar Torx Key
SVHBR/L									
1616 H11	16	16	100	20	VBM.11 03..	SSV M2,5X7,5	-	-	T08
2020 K11	20	20	125	25					
2525 M11	25	25	150	32					
1616 H16	16	16	100	20	VBM.16 04..	SSV M3,5X14	BAX- VB16	SBV-M5.05 A-3.5	T15
2020 K16	20	20	125	25					
2525 M16	25	25	150	32					
3232 P16	32	32	170	40					

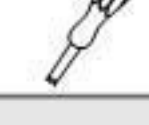

KOD CODE	ÖLÇÜLER DIMENSION (mm)				KESİCİ UÇ INSERT	YEDEK PARÇALAR SPARE PARTS			
	h	b	L	f		Sıkma Vidası Clamp Screw	Altık Shim	Altık Vidası Shim Screw	Anahtar Torx Key
SVZBR / L									
1616 H11	16	16	100	20	VBM.11 03..	SSV M2,5X7,5	-	-	T08
2020 K11	20	20	125	25					
2525 M11	25	25	150	32					
1616 H16	16	16	100	20	VBM.16 04..	SSV M3,5X14	BAX- VB16	SBV-M5.05 A-3.5	T15
2020 K16	20	20	125	25					
2525 M16	25	25	150	32					
3232 P16	32	32	170	40					

S SİSTEM DIŞ TORNA KATERLERİ

S System External Lathe Tool Holders

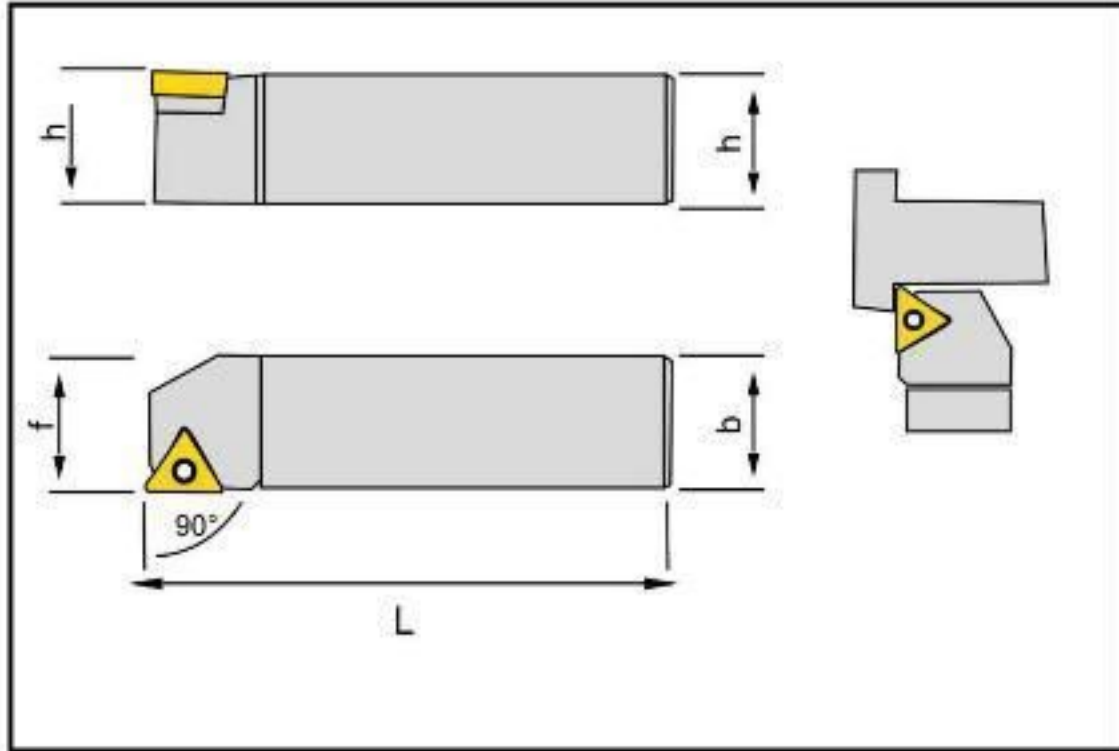

KOD CODE	ÖLÇÜLER DIMENSION (mm)				KESİCİ UÇ INSERT	YEDEK PARÇALAR SPARE PARTS			
	h	b	L	f		Sıkma Vidası Clamp Screw	Altlık Shim	Altlık Vidası Shim Screw	Anahtar Torx Key
STJCR / L									
0808 E09	08	08	70	10	TCM. 09 02..	SSV M2,2 X6	-	-	T07
1010 E09	10	10	70	12		TCM.11 02..	SSV M2,5X7,5	-	-
1212F11	12	12	80	16	TCM.16 T3..		SSV M3,5X11	BAX- TC16	SBV-M5.05 A-3,5X11
1616H11	16	16	100	20					
1616 H16	16	16	100	20					
2020 K16	20	20	125	25					
2525 M16	25	25	150	32					
3232 P16	32	32	170	40					

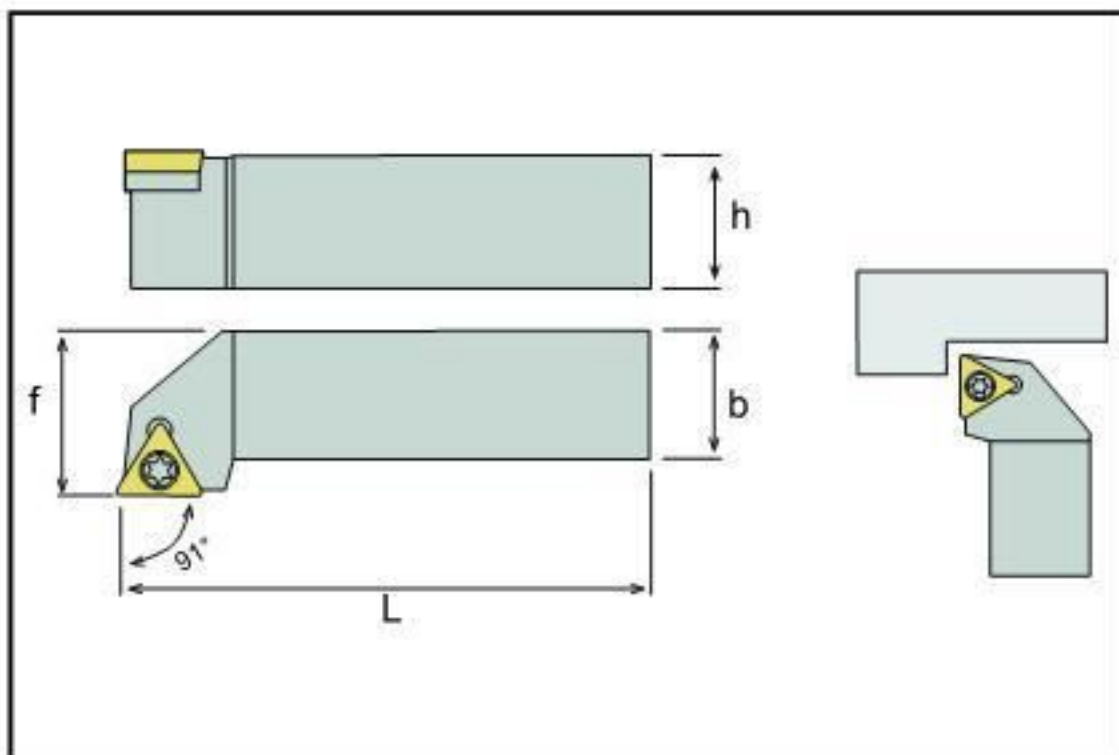

KOD CODE	ÖLÇÜLER DIMENSION (mm)				KESİCİ UÇ INSERT	YEDEK PARÇALAR SPARE PARTS			
	h	b	L	f		Sıkma Vidası Clamp Screw	Altlık Shim	Altlık Vidası Shim Screw	Anahtar Torx Key
STGCR / L									
0808 E09	08	08	70	10	TCM. 09 02..	SSV M2,2 X6	-	-	T07
1010 E09	10	10	70	12		TCM.11 02..	SSV M2,5X7,5	-	-
1212F11	12	12	80	16	TCM.16 T3..		SSV M3,5X11	BAX- TC 16	SBV-M5.05 A-3,5
1616H11	16	16	100	20					
1616 H16	16	16	100	20					
2020 K16	20	20	125	25					
2525 M16	25	25	150	32					
3232 P16	32	32	170	40					

S SİSTEM DIŞ TORNA KATERLERİ S System External Lathe Tool Holders

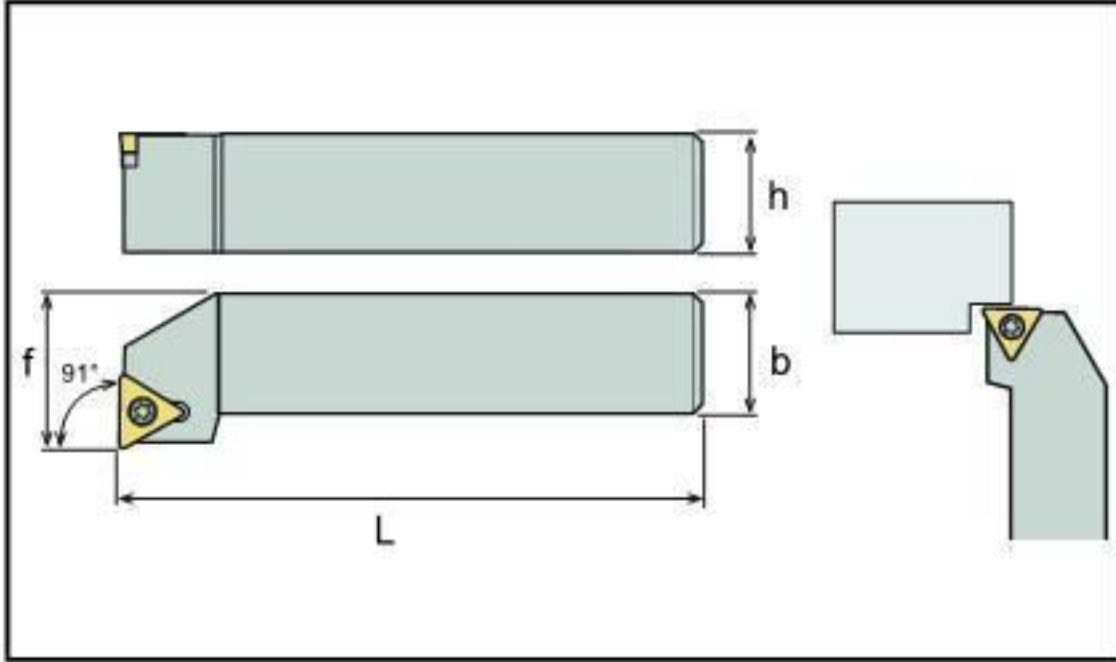

KOD CODE	ÖLÇÜLER DIMENSION (mm)				KESİCİ UÇ INSERT	YEDEK PARÇALAR SPARE PARTS			
	h	b	L	f		Sıkma Vidası Clamp Screw	Altlık Shim	Altlık Vidası Shim Screw	Anahtar Torx Key
STFCR / L									
0808 E09	08	08	70	10	TCM.09.02..	SSV M2,2 X6	-	-	T07
1010 E09	10	10	70	12		SSV M2,5X7,5	-	-	T08
1212F11	12	12	80	16	TCM.11.02..	SSV M2,5X7,5	-	-	T08
1616H11	16	16	100	20		SSV M3,5X11	BAX- TC16	SBV-M5.05 A-3,5	T15
1616 H16	16	16	100	20	TCM.16 T3..	SSV M3,5X11	BAX- TC16	SBV-M5.05 A-3,5	T15
2020 K16	20	20	125	25		SSV M3,5X11	BAX- TC16	SBV-M5.05 A-3,5	T15
2525 M16	25	25	150	32		SSV M3,5X11	BAX- TC16	SBV-M5.05 A-3,5	T15
3232 P16	32	32	170	40		SSV M3,5X11	BAX- TC16	SBV-M5.05 A-3,5	T15

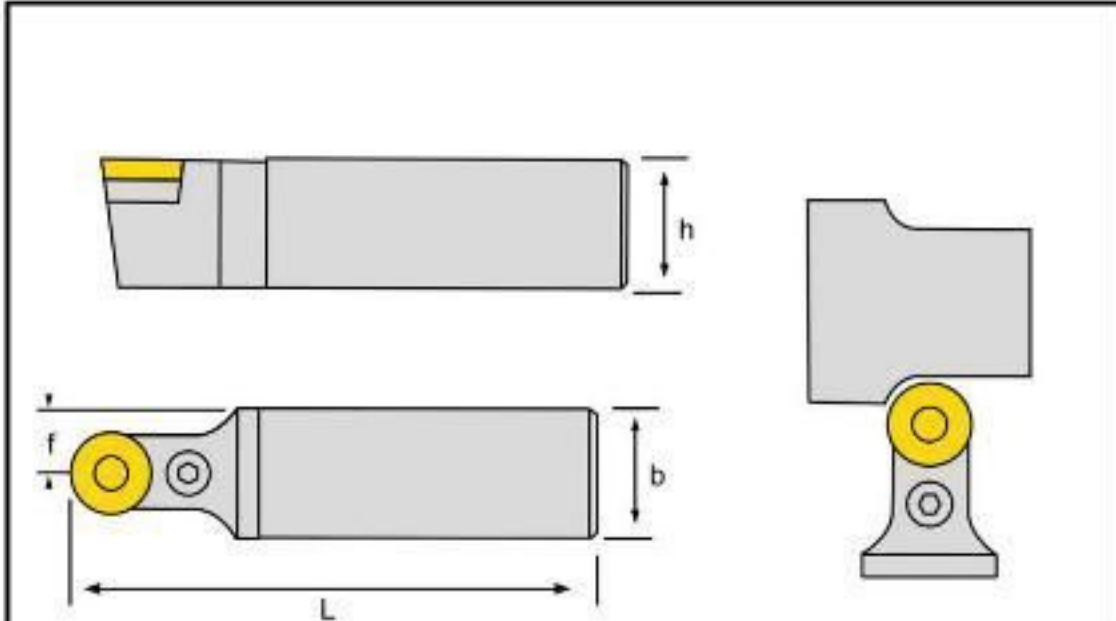

KOD CODE	ÖLÇÜLER DIMENSION (mm)				KESİCİ UÇ INSERT	YEDEK PARÇALAR SPARE PARTS			
	h	b	L	f		Sıkma Vidası Clamp Screw	Altlık Shim	Altlık Vidası Shim Screw	Anahtar Torx Key
SRDCN									
1616 H08	16	16	100	08	RC.T 0803	SSV M3X8	-	-	T08
2020 K08	20	20	125	10		SSV M3,5X9	-	-	T15
2525 M08	25	25	150	12,5		SSV M3,5X11	-	-	T15
1616 H10	16	16	100	08	RC.T 1003	SSV M3,5X9	-	-	T15
2020 K10	20	20	125	10		SSV M3,5X11	-	-	T15
2525 M10	25	25	150	12,5		SSV M5X12	-	-	T20
3232 P10	32	32	170	16	RC.T 1204	SSV M3,5X11	-	-	T15
2020 K12	20	20	125	10		SSV M3,5X11	-	-	T15
2525 M12	25	25	150	12,5		SSV M5X12	-	-	T20
3232 P12	32	32	170	16	RC.T 1605	SSV M3,5X11	-	-	T15
2525 M16	25	25	150	12,5		SSV M5X12	-	-	T20
3232 P16	32	32	170	16		SSV M5X12	-	-	T20

S SİSTEM DIŞ TORNA KATERLERİ

S System External Lathe Tool Holders

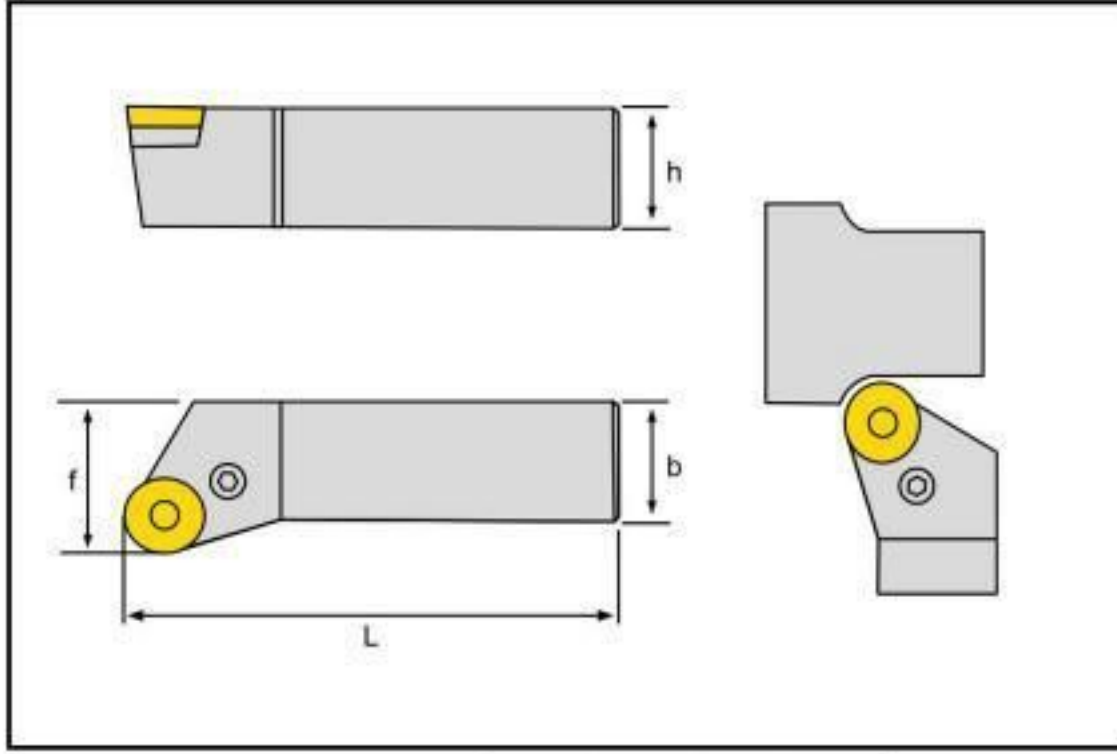

KOD CODE	ÖLÇÜLER DIMENSION (mm)				KESİCİ UÇ INSERT	YEDEK PARÇALAR SPARE PARTS			
	h	b	L	f		Sıkma Vidası Clamp Screw	Altık Shim	Altık Vidası Shim Screw	Anahtar Torx Key
SRGCR									
1616 H08	16	16	100	20	RC.T 0803	SSV M3X8	-	-	T08
2020 K08	20	20	125	25					
2525 M08	25	25	150	32					
1616 H10	16	16	100	20	RC.T 1003	SSV M3,5X9	-	-	T15
2020 K10	20	20	125	25					
2525 M10	25	25	150	32					
3232 P10	32	32	170	40	RC.T 1204	SSV M3,5X11	-	-	T15
2020 K12	20	20	125	25					
2525 K12	25	25	150	32					
3232 K12	32	32	170	40	RC.T 1605	SSV M5X12	-	-	T20
2525 M16	25	25	150	32					
3232 P16	32	32	170	40					

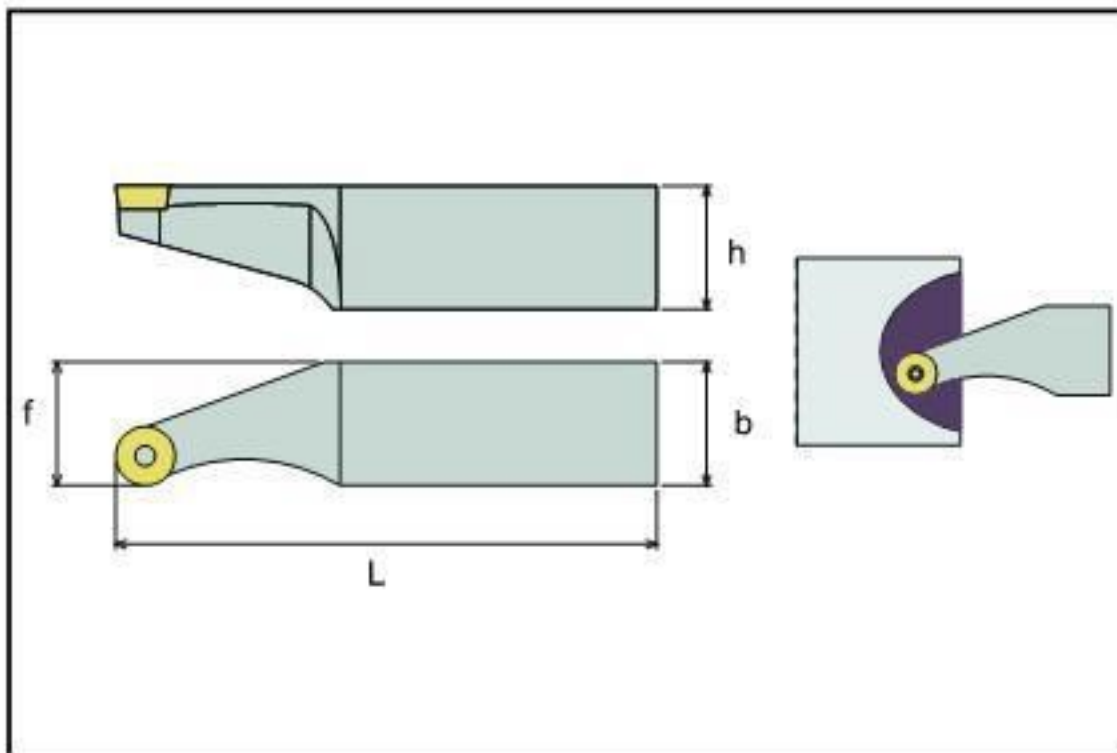

KOD CODE	ÖLÇÜLER DIMENSION (mm)				KESİCİ UÇ INSERT	YEDEK PARÇALAR SPARE PARTS			
	h	b	L	f		Sıkma Vidası Clamp Screw	Altık Shim	Altık Vidası Shim Screw	Anahtar Torx Key
SRHCR/L									
2525 M10	25	25	125	25	RC.T 0803	SSV M3,5X9	-	-	T15
2525 M12	25	25	125	25	RC.T 0804	SSV M3,5x14	-	-	T15
2525 M16	25	25	125	25	RC.T 0805	SSV M5X12	-	-	T20



T SİSTEM DELİK TORNA KATERLERİ

T SYSTEM BORING BARS

T SİSTEM DELİK TORNA KATERLERİ

T System Boring Bars

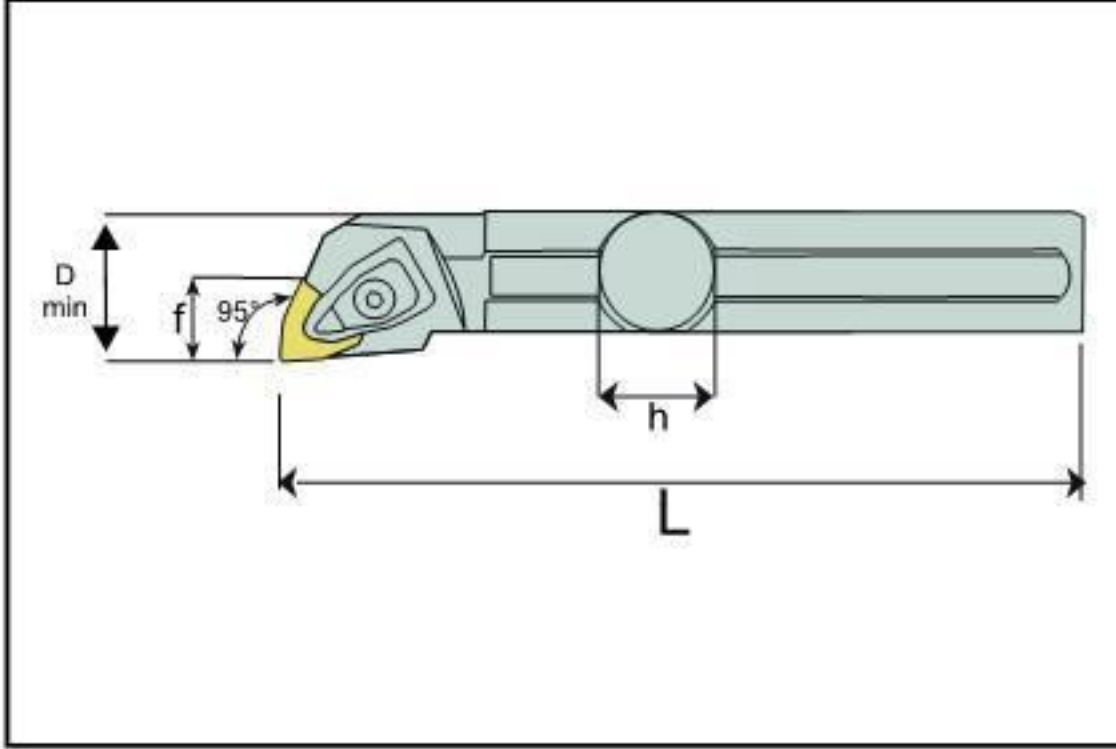



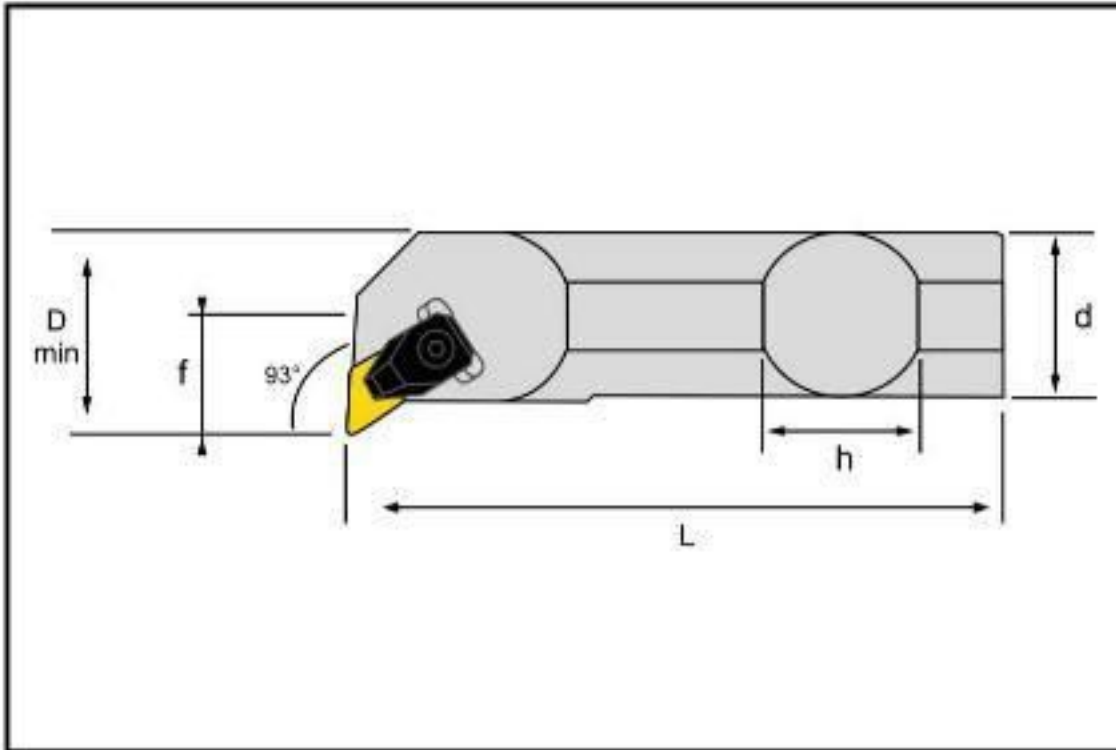



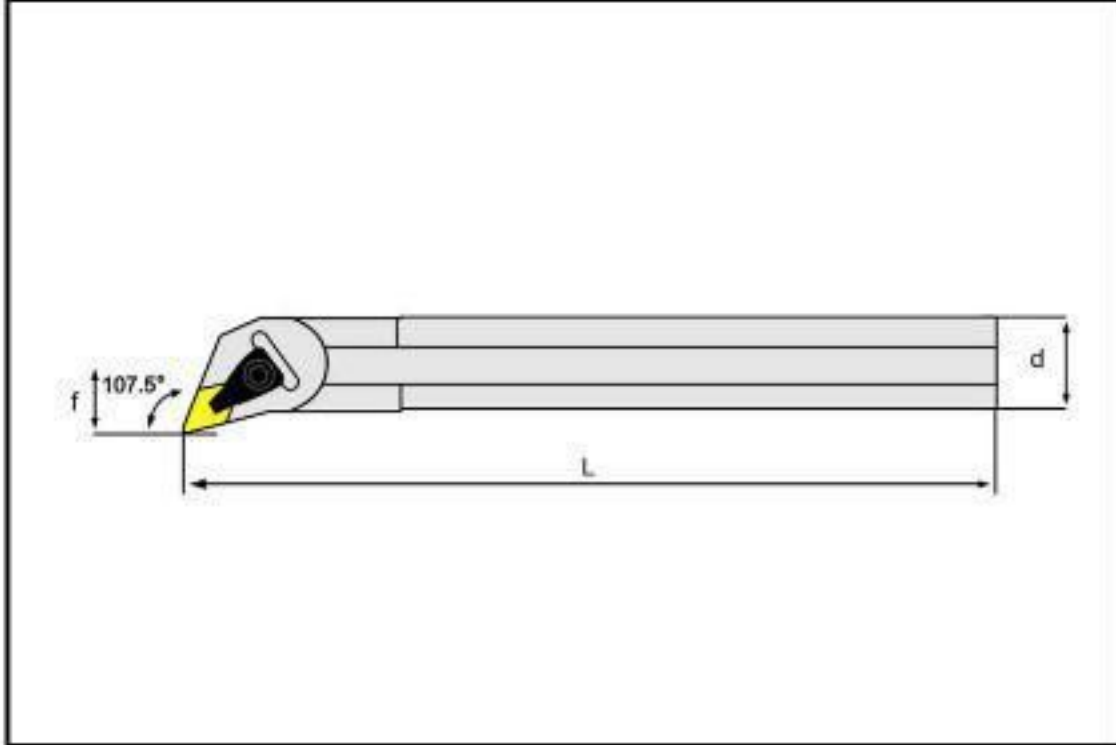

KOD CODE	ÖLÇÜLER DIMENSION (mm)					KESİCİ UÇ INSERT	YEDEK PARÇALAR SPARE PARTS					
	h	b	L	f	D min		Baskı Parçası Clamp	Baskı Vidası Screw	Altlık Shim	Altlık Vidası Shim Screw	Pul Stamp	Anahtar Allen Key
TWLNR/L												
S25S TWLNR/L-06	25	23	250	17	≥32	WNM.06 04..	TSK2	TSBV M5x23,5	-	-	TSP 6,5X12	AA3
S32T TWLNR/L-06	32	30	300	22	≥40							
S25S TWLNR/L-08	25	23	250	17	≥32	WNM.08 04..	TSK1	TSBV M6x30	BAX- WN08	TSAV M4X10	TSP 6,5X12	AA3
S32T TWLNR/L-08	32	30	300	22	≥40							
S40U TWLNR/L-08	40	37	350	27	≥50							
S50V TWLNR/L-08	50	47	400	35	≥63							



KOD CODE	ÖLÇÜLER DIMENSION (mm)					KESİCİ UÇ INSERT	YEDEK PARÇALAR SPARE PARTS					
	h	b	L	f	D min		Baskı Parçası Clamp	Baskı Vidası Screw	Altlık Shim	Altlık Vidası Shim Screw	Pul Stamp	Anahtar Allen Key
TDUNR/L												
S20R						DNM.11 04..	TSK2	TSBV M5x23,5	BAX DN11	TSAV M4X10	TSP 6,5X12	AA3
S25S TDUNR/L-11	25	23	250	17	≥32							
S32T TDUNR/L-11	32	30	300	22	≥40	DNM.15 06..	TSK1	TSBV M6x30	BAX- DN15	TSAV M4X10	TSP 6,5X12	AA3
S25S TDUNR/L-15	25	23	250	17	≥32							
S32T TDUNR/L-15	32	30	300	22	≥40							
S40U TDUNR/L-15	40	37	350	27	≥50							
S50V TDUNR/L-15	50	47	400	35	≥63							

T SİSTEM DELİK TORNA KATERLERİ T System Boring Bars



KOD CODE	ÖLÇÜLER DIMENSION (mm)					KESİCİ UÇ INSERT	YEDEK PARÇALAR SPARE PARTS					
	h	b	L	f	D min		Baskı Parçası Clamp	Baskı Vidası Screw	Altlık Shim	Altlık Vidası Shim Screw	Pul Stamp	Anahtar Allen Key
TDQNR/L												
S25S TDQNR/L-11	25	23	250	17	≥32	DNM.11 04..	TSK2	TSBV M5x23,5	BAX- DN11	TSAV M4X10	TSP 6,5X12	AA3
S32T TDQNR/L-11	32	30	300	22	≥40							
S25S TDQNR/L-15	25	23	150	17	≥32	DNM.15 06..	TSK1	TSBV M6x30	BAX- DN15	TSAV M4X10	TSP 6,5X12	AA3
S32T TDQNR/L-15	32	30	300	22	≥40							
S40U TDQNR/L-15	40	37	350	27	≥50							
S50V TDQNR/L-15	50	47	400	35	≥63							

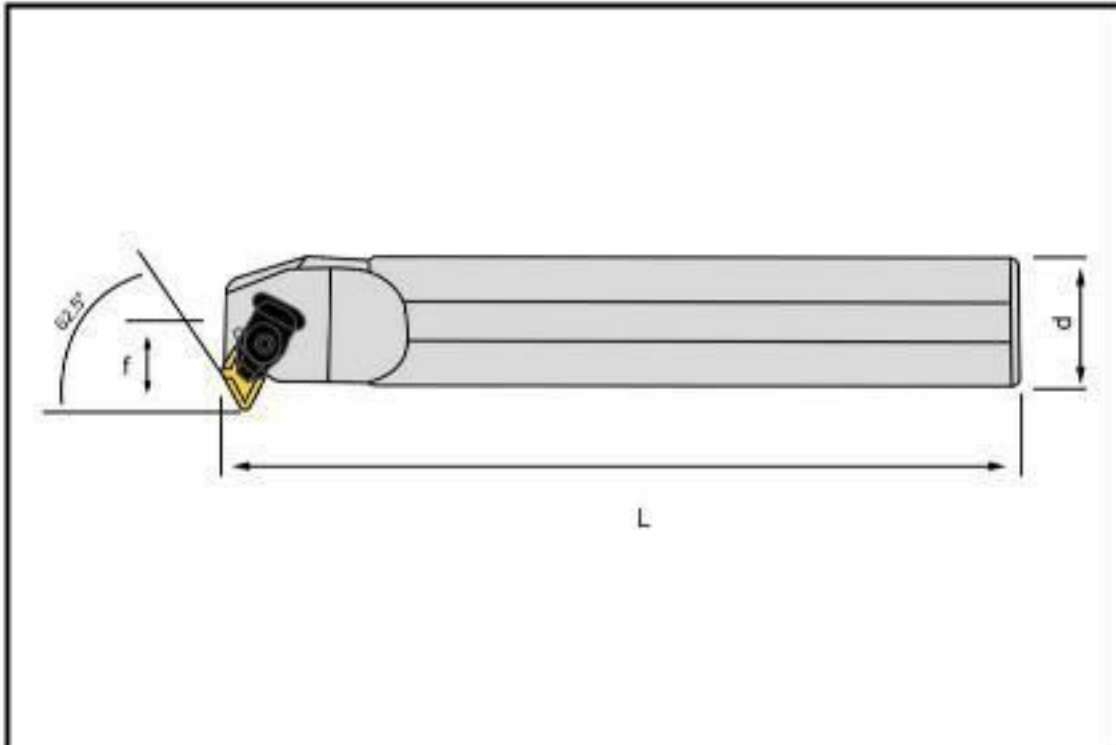

KOD CODE	ÖLÇÜLER DIMENSION (mm)					KESİCİ UÇ INSERT	YEDEK PARÇALAR SPARE PARTS					
	h	b	L	f	D min		Baskı Parçası Clamp	Baskı Vidası Screw	Altlık Shim	Altlık Vidası Shim Screw	Pul Stamp	Anahtar Allen Key
TD-NR/L												
S25S TD-NR/L-11	25	23	250	17	≥32	DNM.11 04..	TSK2	TSBV M5x23,5	BAX- DN11	TSAV M4X10	TSP 6,5X12	AA3
S32T TD-NR/L-15	32	30	300	26	≥44							
S40U TD-NR/L-15	40	37	350	29	≥52	DNM.15 06..	TSK1	TSBV M6x30	BAX- DN15	TSAV M4X10	TSP 6,5X12	AA3
S50V TD-NR/L-15	50	47	400	35	≥67							

T SİSTEM DELİK TORNA KATERLERİ

T System Boring Bars

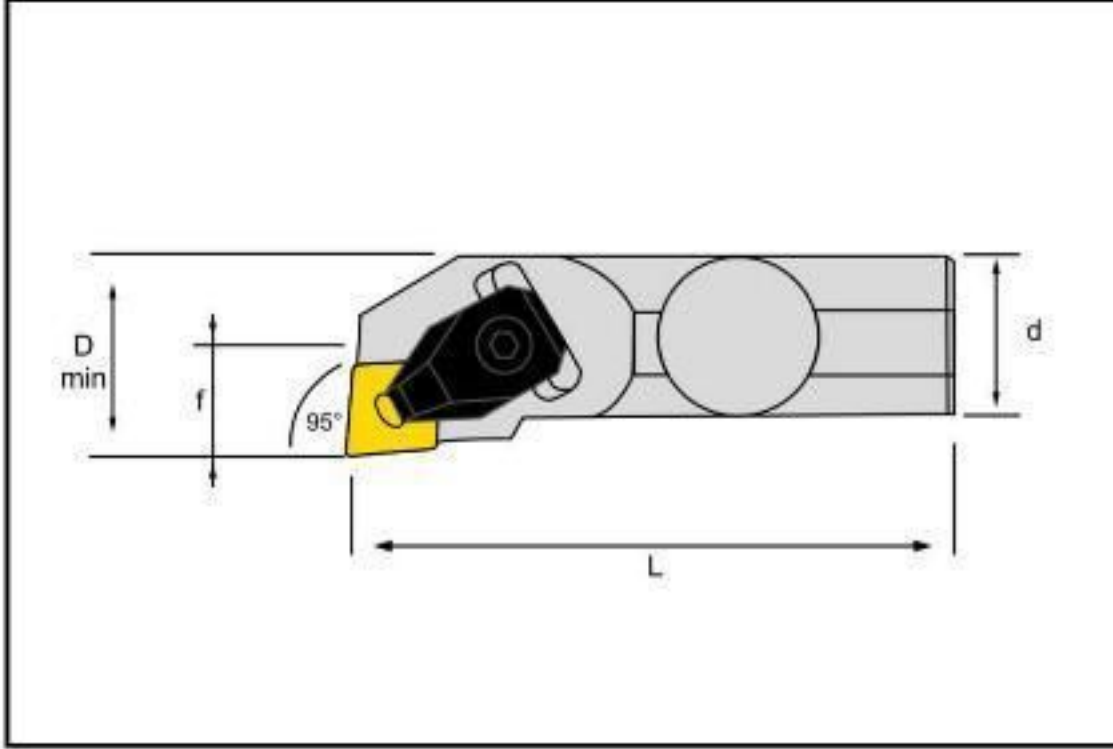

KOD CODE	ÖLÇÜLER DIMENSION (mm)					KESİCİ UÇ INSERT	YEDEK PARÇALAR SPARE PARTS					
	h	b	L	f	D min		Baskı Parçası Clamp	Baskı Vidası Screw	Altlık Shim	Altlık Vidası Shim Screw	Pul Stamp	Anahtar Allen Key
TCLNR/L												
S25S TCLNR/L-12	25	23	250	17	≥32	CNM.12 04..	TSK1	TSBV M6x30	BAX- CN12	TSAV M4X10	TSP 6,5X12	AA3
S32T TCLNR/L-12	32	30	300	22	≥40							
S40U TCLNR/L-12	40	37	350	27	≥50							
S50V TCLNR/L-12	50	47	400	35	≥63							
S32T TCLNR/L-16	32	30	300	22	≥40	CNM. 16 06.	TSK3	TSBV M6X25	BAX- CN16	TSAV M6X12	-	AA3
S40U TCLNR/L-16	40	37	350	27	≥50							
S50V TCLNR/L-16	50	47	400	35	≥63							

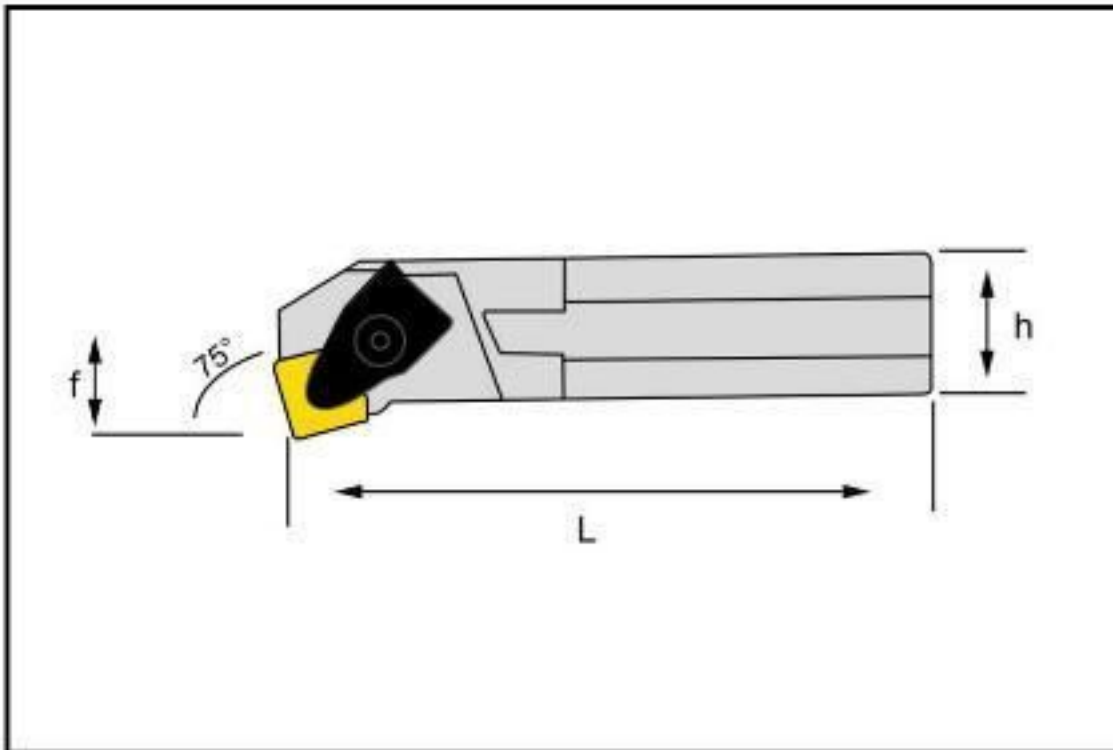

KOD CODE	ÖLÇÜLER DIMENSION (mm)					KESİCİ UÇ INSERT	YEDEK PARÇALAR SPARE PARTS					
	h	b	L	f	D min		Baskı Parçası Clamp	Baskı Vidası Screw	Altlık Shim	Altlık Vidası Shim Screw	Pul Stamp	Anahtar Allen Key
TSKNR/L												
S25S TSKNR/L-12	25	23	250	17	≥32	SNM. 12 04..	TSK1	TSBV M6x30	BAX- SN12	TSAV M4X10	TSP 6,5X12	AA3
S32T TSKNR/L-12	32	30	300	22	≥40							
S40U TSKNR/L-12	40	37	350	27	≥50							
S50V TSKNR/L-12	50	47	400	35	≥63							

T SİSTEM DELİK TORNA KATERLERİ T System Boring Bars

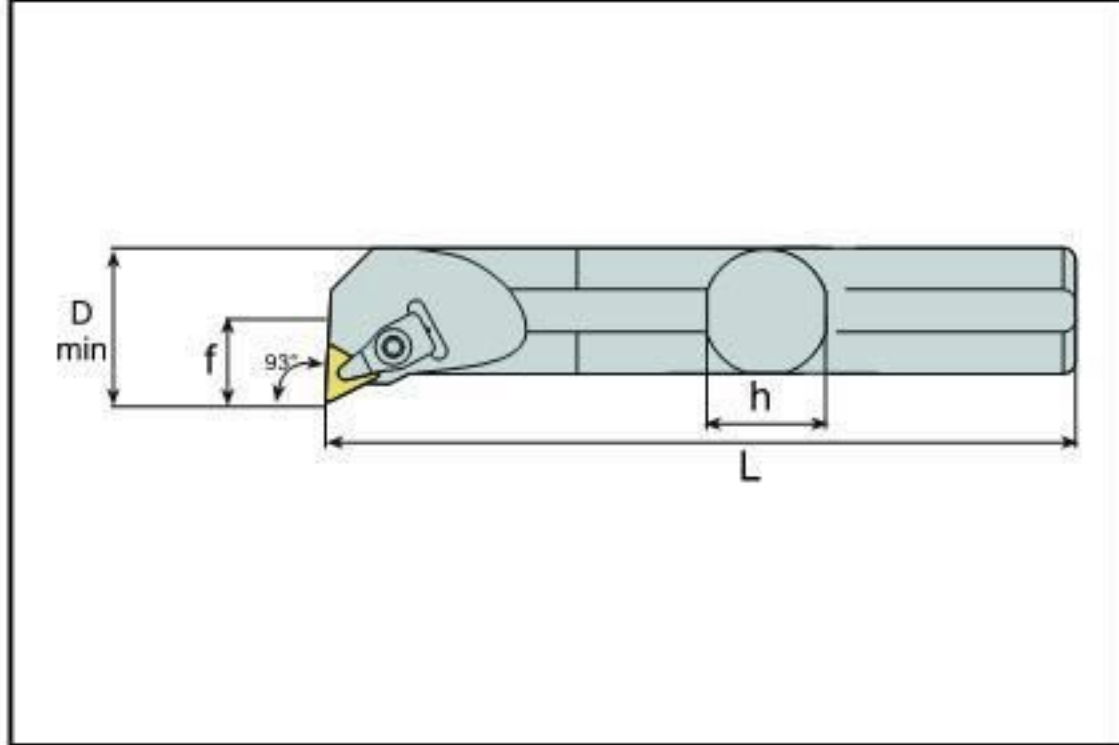

KOD CODE	ÖLÇÜLER DIMENSION (mm)					KESİCİ UÇ INSERT	YEDEK PARÇALAR SPARE PARTS					
	h	b	L	f	D min		Baskı Parçası Clamp	Baskı Vidası Screw	Altlık Shim	Altlık Vidası Shim Screw	Pul Stamp	Anahtar Allen Key
TTUNR												
S25S TTUNR/L-16	25	23	250	17	≥32	TNM.16 04..	TSK2	TSBV M5x23,5	BAX- TN16	TSAV M4X10	TSP 6,5X12	AA3
S32T TTUNR/L-16	32	30	300	22	≥40							
S32T TTUNR/L-22	32	30	300	22	≥40	TNM.22 04..	TSK1	TSBV M6x30	BAX- TN22	TSAV M4X10	TSP 6,5X12	AA3
S40U TTUNR/L-22	40	37	350	27	≥50							
S50V TTUNR/L-22	50	47	400	35	≥63							

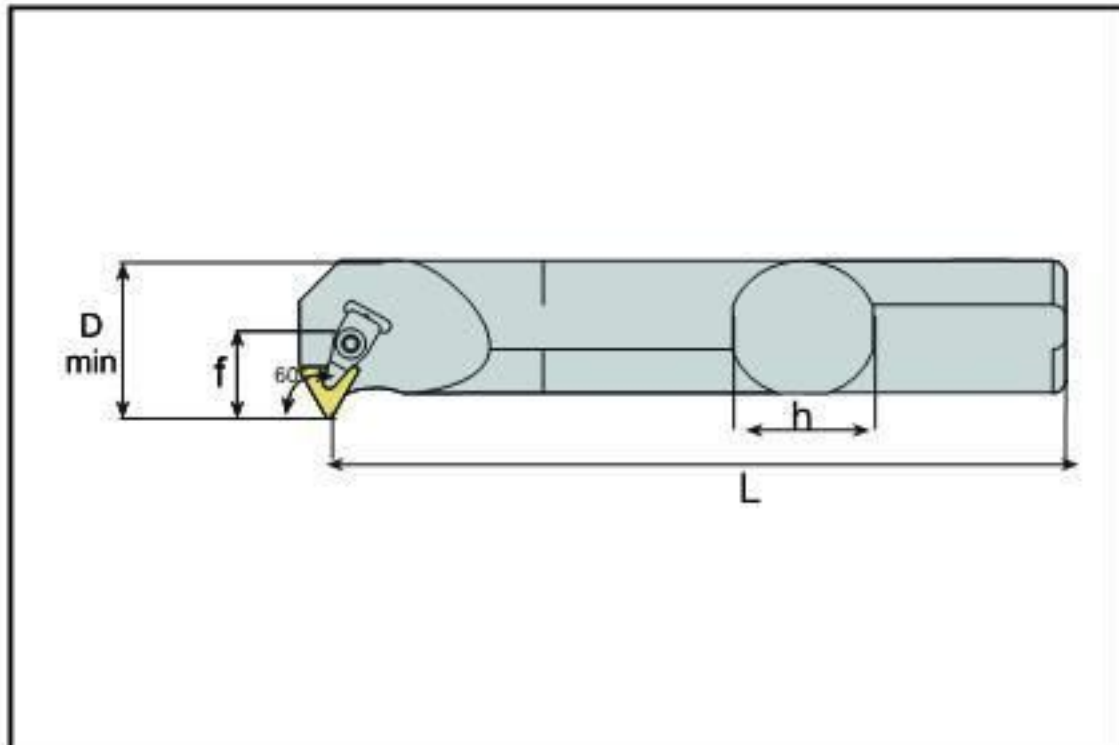

KOD CODE	ÖLÇÜLER DIMENSION (mm)					KESİCİ UÇ INSERT	YEDEK PARÇALAR SPARE PARTS					
	h	b	L	f	D min		Baskı Parçası Clamp	Baskı Vidası Screw	Altlık Shim	Altlık Vidası Shim Screw	Pul Stamp	Anahtar Allen Key
TT-NR/L												
S25S TT-NR/L-16	25	23	250	17	≥32	TNM.16 04..	TSK2	TSBV M5x23,5	BAX- TN16	TSAV M4X10	TSP 6,5X12	AA3
S32T TT-NR/L-16	32	30	300	22	≥40							

T SİSTEM DELİK TORNA KATERLERİ T System Boring Bars

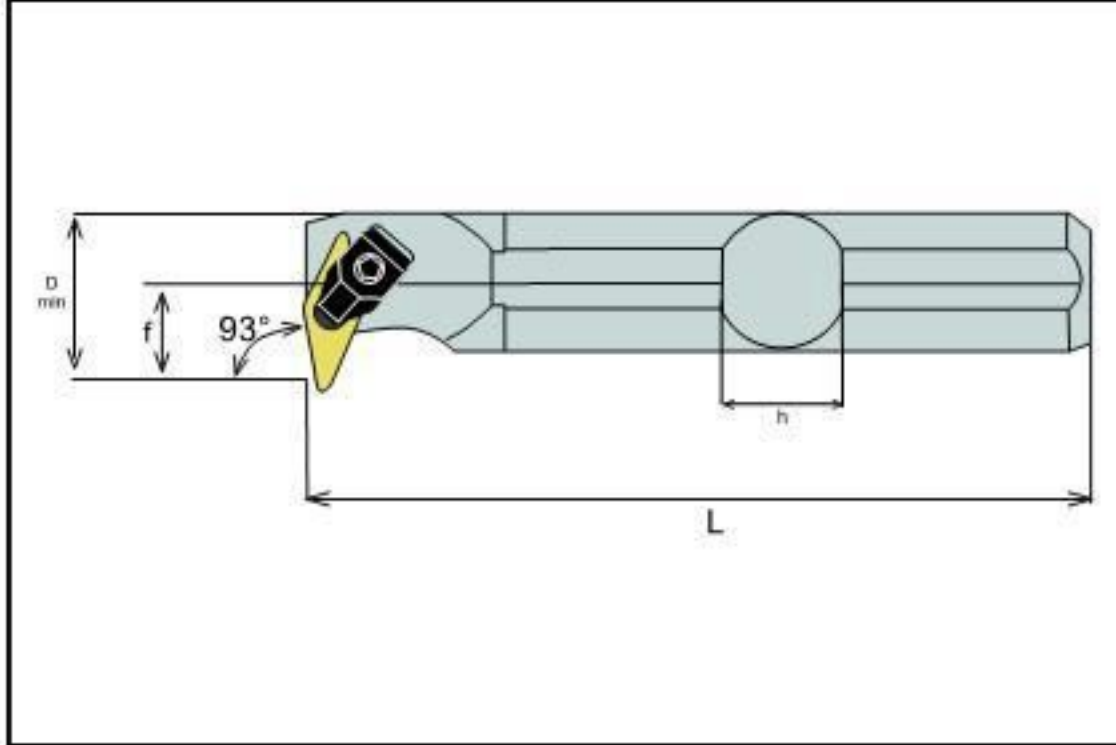

KOD CODE	ÖLÇÜLER DIMENSION (mm)					KESİCİ UÇ INSERT	YEDEK PARÇALAR SPARE PARTS					
	h	b	L	f	D min		Baskı Parçası Clamp	Baskı Vidası Screw	Altlık Shim	Altlık Vidası Shim Screw	Pul Stamp	Anahtar Allen Key
TVUNR/L												
S25S TVUNR/L-16	25	23	250	17	≥32	VNM.16 04..	TSK5	TSBV M6x30	BAX- VN16	TSAV M4X10	TSP 6,5X12	AA3
S32T TVUNR/L-16	32	30	300	22	≥40							
S40U TVUNR/L-16	40	37	350	27	≥50							

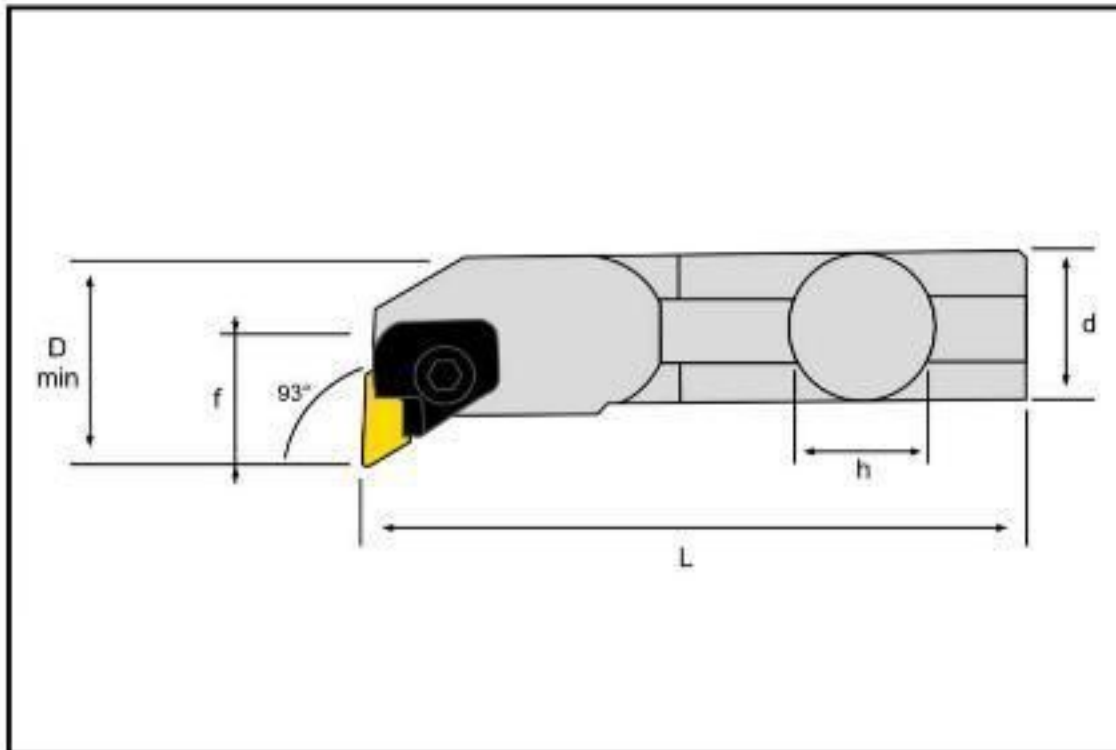

KOD CODE	ÖLÇÜLER DIMENSION (mm)					KESİCİ UÇ INSERT	YEDEK PARÇALAR SPARE PARTS					
	h	b	L	f	D min		Baskı Parçası Clamp	Baskı Vidası Screw	Altlık Shim	Altlık Vidası Shim Screw	Yay Spring	Anahtar Allen Key
CKUNR/L												
S25S CKUNR/L-16	25	23	250	19	≥34	KNUX 16 04..	CSK1/R CSK1/L	CSBV M6x30	BAX- KN-R/L-16	CSAV M3X10	BAX- Y25	AA5
S28S CKUNR/L-16	28	26	290	19	≥38							
S32T CKUNR/L-16	32	30	300	22	≥40							
S40U CKUNR/L-16	40	37	350	27	≥50							
S50V CKUNR/L-16	50	47	400	35	≥63							

The image shows three M-system perforated lathe tool holders arranged horizontally. Each holder is made of grey metal and features a black and yellow insert. A long, thin, yellow chip is draped over the holders, forming several loops. The background is plain white. A green horizontal bar is positioned across the middle of the image, containing the text 'M SISTEM DELIK TORNA KATERLERI'.

M SISTEM DELIK TORNA KATERLERI

M SYSTEM PERFORATED LATHE TOOL HOLDERS

M SİSTEM DELİK TORNA KATERLERİ M System Boring Bars

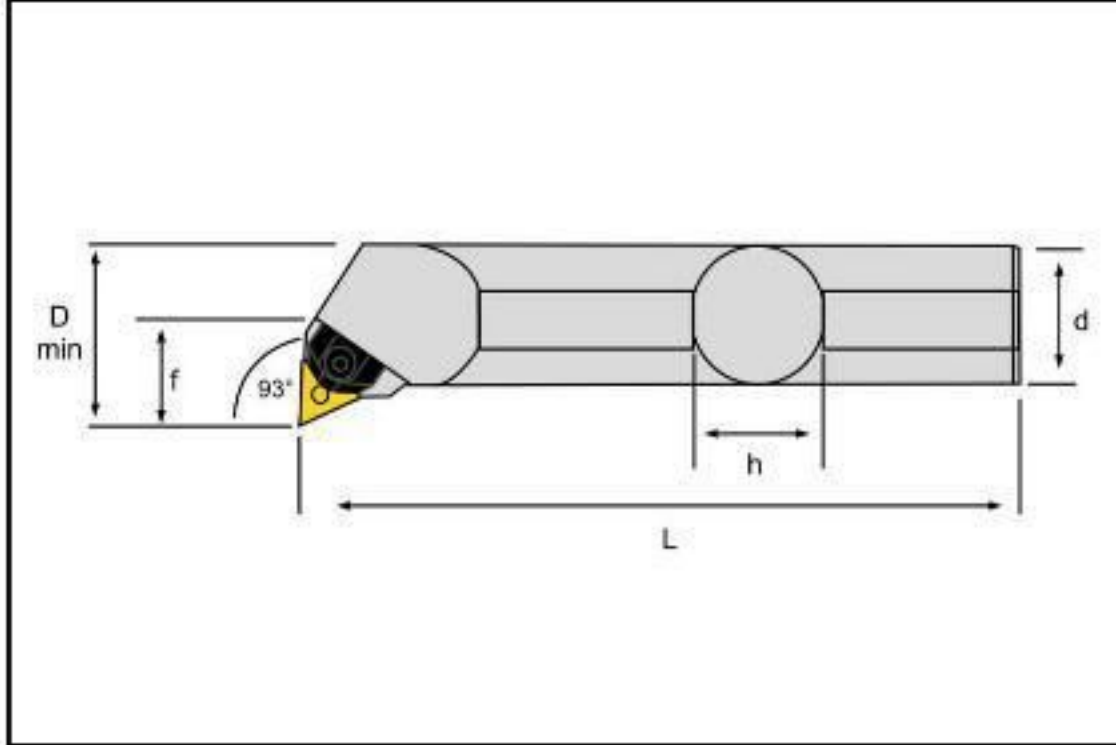



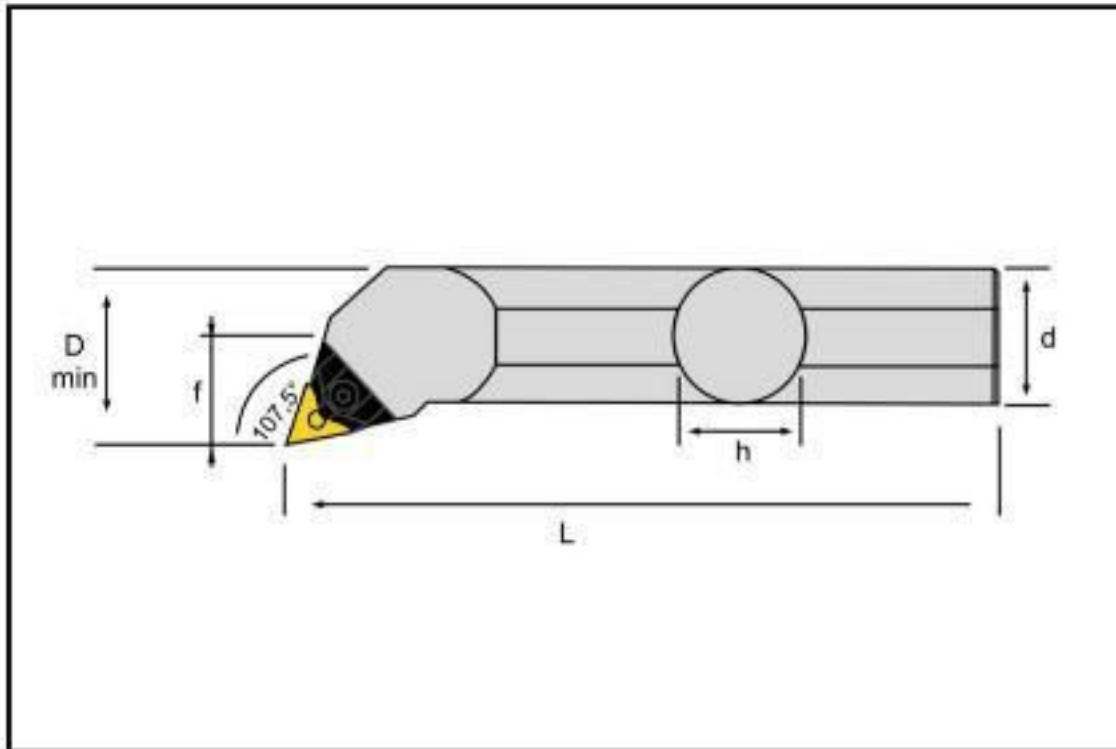



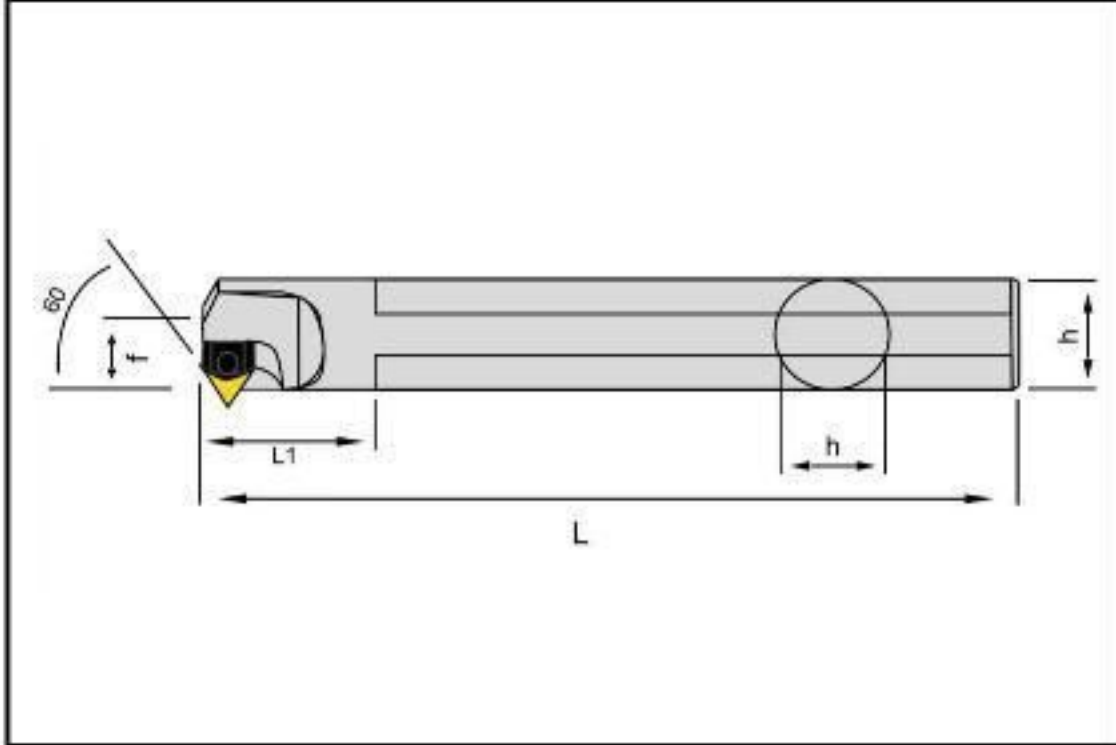

KOD CODE	ÖLÇÜLER DIMENSION (mm)					KESİCİ UÇ INSERT	YEDEK PARÇALAR SPARE PARTS					
	h	b	L	f	D min		Baskı Parçası Clamp	Baskı Vidası Screw	Altık Shim	Pim Pin	Pul Stamp	Anahtar Allen Key
MTUNR/L												
S20R MTUNR/L-16	20	18	200	13	≥25	TNM.16 04..	MSK-2	MSBV M5X23,5	-	BPM1 3,70x5	-	AA3
S25S MTUNR/L-16	25	23	250	17	≥32	TNM.16 04..	MSK-1	MSBV M6x30	BAX- TN16	BPM1 3,70x5	TSP 6x30	AA3
S32T MTUNR/L-16	32	30	300	22	≥40							
S40U MTUNR/L-16	40	37	350	27	≥50							
S32T MTUNR/L-22	32	30	300	22	≥40	TNM.22 04..	MSK-1	MSBV M6x30	BAX- TN22	BPM2 5x6	TSP 6x30	AA3
S40U MTUNR/L-22	40	37	350	27	≥50							
S50V MTUNR/L-22	50	47	400	35	≥63							









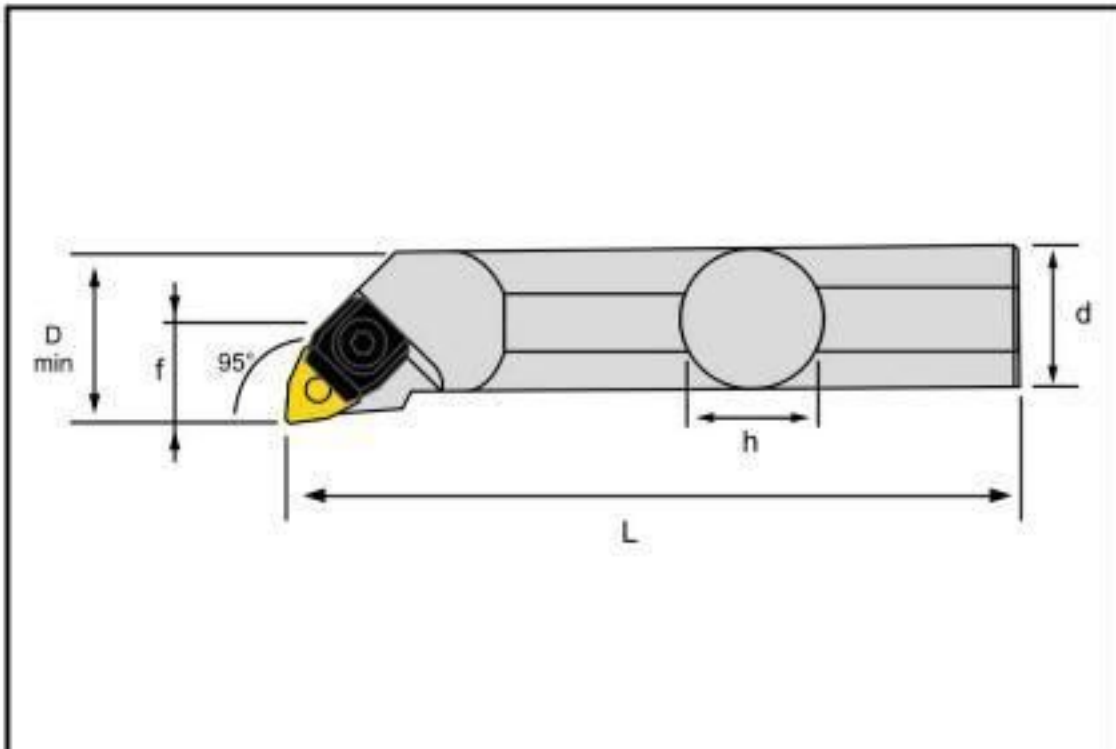

KOD CODE	ÖLÇÜLER DIMENSION (mm)					KESİCİ UÇ INSERT	YEDEK PARÇALAR SPARE PARTS					
	h	b	L	f	D min		Baskı Parçası Clamp	Baskı Vidası Screw	Altık Shim	Pim Pin	Pul Stamp	Anahtar Allen Key
MTQNR/L												
S20R MTQNR/L-16	20	18	200	13	≥25	TNM.16 04..	MSK-2	MSBV M5X23,5	-	BPM1 3,70x5	-	AA3
S25S MTQNR/L-16	25	23	250	17	≥32	TNM.16 04..	MSK-1	MSBV M6x30	BAX- TN16	BPM1 3,70x5	TSP 6x30	AA3
S32T MTQNR/L-16	32	30	300	22	≥40							
S40U MTQNR/L-16	40	37	350	27	≥50							
S32T MTQNR/L-22	32	30	300	22	≥40	TNM.22 04..	MSK-1	MSBV M6x30	BAX- TN22	BPM2 5x6	TSP 6x30	AA3
S40U MTQNR/L-22	40	37	350	27	≥50							
S50V MTQNR/L-22	50	47	400	35	≥63							

M SİSTEM DELİK TORNA KATERLERİ M System Boring Bars



KOD CODE	ÖLÇÜLER DIMENSION (mm)					KESİCİ UÇ INSERT	YEDEK PARÇALAR SPARE PARTS					
	h	b	L	f	D _{min}		Baskı Parçası Clamp	Baskı Vidası Screw	Altlık Shim	Pim Pin	Pul Stamp	Anahtar Allen Key
MT-NR/L												
S25S MT-NR-16	25	23	250	17	≥32	TNM.16 04..	MSK-1	MSBV M6x30	BAX- TN16	BPM1 3,70x5	TSP 6x30	AA3
S32T MT-NR-16	32	30	300	22	≥40							
S40U MT-NR-16	40	37	350	27	≥50							
S40U MT-NR-22	40	37	350	27	≥50	TNM.22 04..	MSK-1	MSBV M6x30	BAX- TN22	BPM2 5x6	TSP 6x30	AA3
S50V MT-NR-22	50	47	400	35	≥63							



KOD CODE	ÖLÇÜLER DIMENSION (mm)					KESİCİ UÇ INSERT	YEDEK PARÇALAR SPARE PARTS					
	h	b	L	f	D _{min}		Baskı Parçası Clamp	Baskı Vidası Screw	Altlık Shim	Pim Pin	Pul Stamp	Anahtar Allen Key
MWLNR/L												
S16P MWLRN/L-16	16	15	170	11	≥21	WNM.06 04..	MSK-4	MSBV M5x23,5	-	BPM1 3,70x5	-	AA3
S20R MWLRN/L-06	20	18	200	13	≥25							
S25S MWLRN/L-06	25	23	250	17	≥32							
S25S MWLRN/L-08	25	23	250	17	≥32	WNM.08 04..	MSK-3	MSBV M6x30	BAX- WN08	BPM3 5x6	TSP 6x30	AA3
S32T MWLRN/L-08	32	30	300	22	≥40							
S40U MWLRN/L-08	40	37	350	27	≥50							
S50V MWLRN/L-08	50	47	400	35	≥63							



S SİSTEM DELİK TORNA KATERLERİ

S SYSTEM BORING BARS

S SİSTEM DELİK TORNA KATERLERİ S System Boring Bars

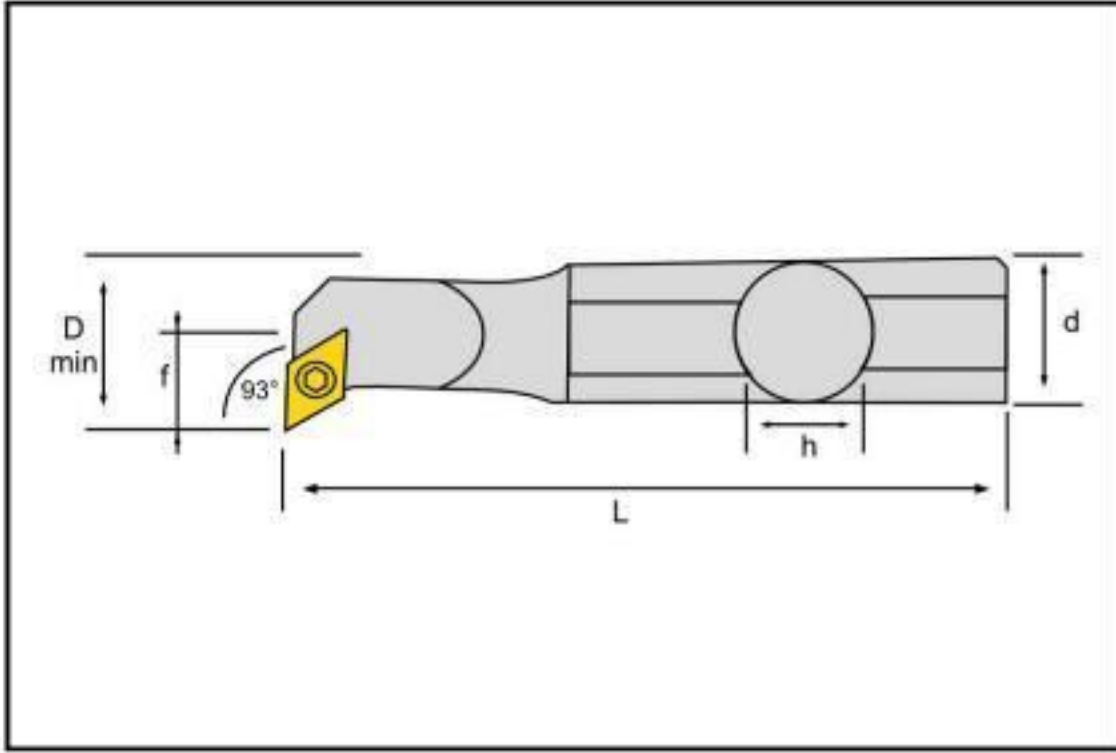

KOD CODE	ÖLÇÜLER DIMENSION (mm)					KESİCİ UÇ INSERT	YEDEK PARÇALAR SPARE PARTS			
	h	b	L	f	D min		Sıkma Vidası Clamp Screw	Altık Shim	Altık Vidası Shim Screw	Anahtar Torx Key
SDUCR/L										
S10K SDUCR/L-07	10	09	125	07	≥13	DCM 07 02..	SSV M2,5X7,5	-	-	T08
S12K SDUCR/L-07	12	11	125	09	≥16					
S16P SDUCR/L-07	16	15	170	11	≥21					
S16P SDUCR/L-11	16	15	170	11	≥21	DCM 11 T3..	SSV M3,5X11	-	-	T15
S20R SDUCR/L-11	20	18	200	13	≥25					
S25S SDUCR/L-11	25	23	250	17	≥32					
S32T SDUCR/L-11	32	30	300	22	≥40					
S40U SDUCR/L-11	40	37	350	27	≥50	DCM 07 02..	SSV M2,5X7,5	-	-	T08
S10K 16X10 SDUCR/L-07	16	15	150	07	≥13					
S12K 16X12 SDUCR/L-07	16	15	150	09	≥16					

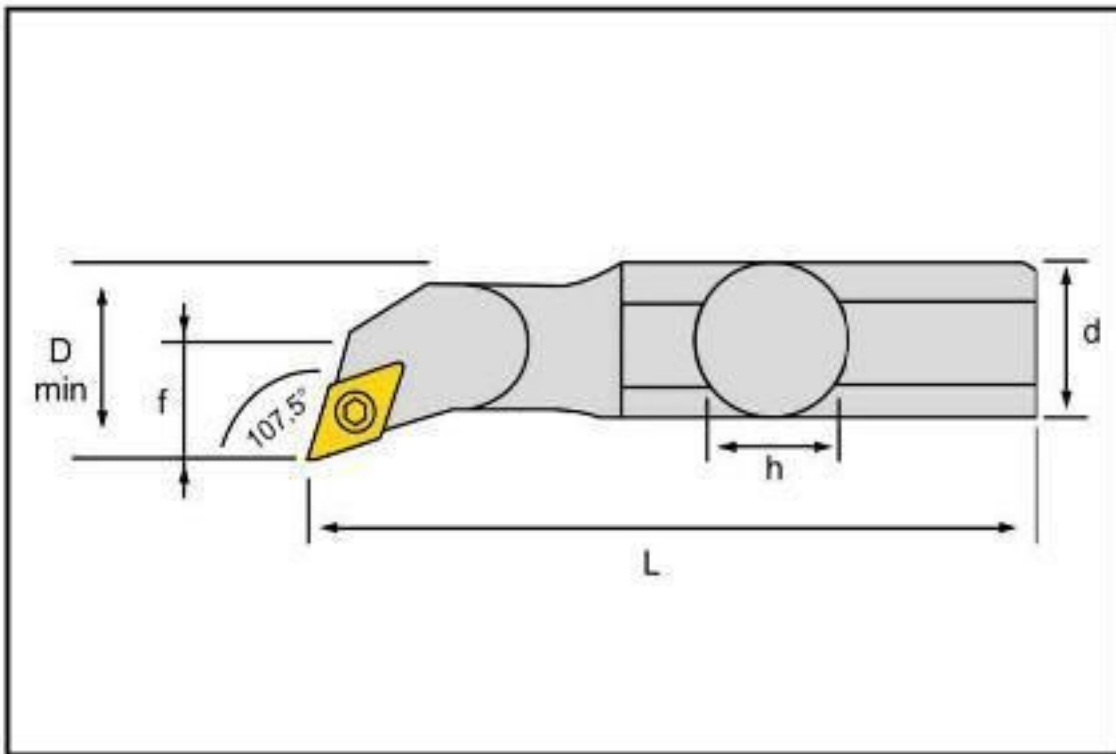

KOD CODE	ÖLÇÜLER DIMENSION (mm)					KESİCİ UÇ INSERT	YEDEK PARÇALAR SPARE PARTS			
	h	b	L	f	D min		Sıkma Vidası Clamp Screw	Altık Shim	Altık Vidası Shim Screw	Anahtar Torx Key
SDQCR/L										
S10K SDQCR/L-07	10	09	125	07	≥13	DCM 07 02..	SSV M2,5X7,5	-	-	T08
S12K SDQCR/L-07	12	11	125	09	≥16					
S16P SDQCR/L-07	16	15	170	11	≥21					
S16P SDQCR/L-11	16	15	170	11	≥21	DCM 11 T3..	SSV M3,5X11	-	-	T15
S20R SDQCR/L-11	20	18	200	13	≥25					
S25S SDQCR/L-11	25	23	250	17	≥32					
S32T SDQCR/L-11	32	30	300	22	≥40					
S40U SDQCR/L-11	40	37	350	27	≥50	DCM 07 02..	SSV M2,5X7,5	-	-	T08
S10K 16X10 SDQCR/L-07	16	15	150	07	≥13					
S12K 16X12 SDQCR/L-07	16	15	150	09	≥16					

S SİSTEM DELİK TORNA KATERLERİ S System Boring Bars

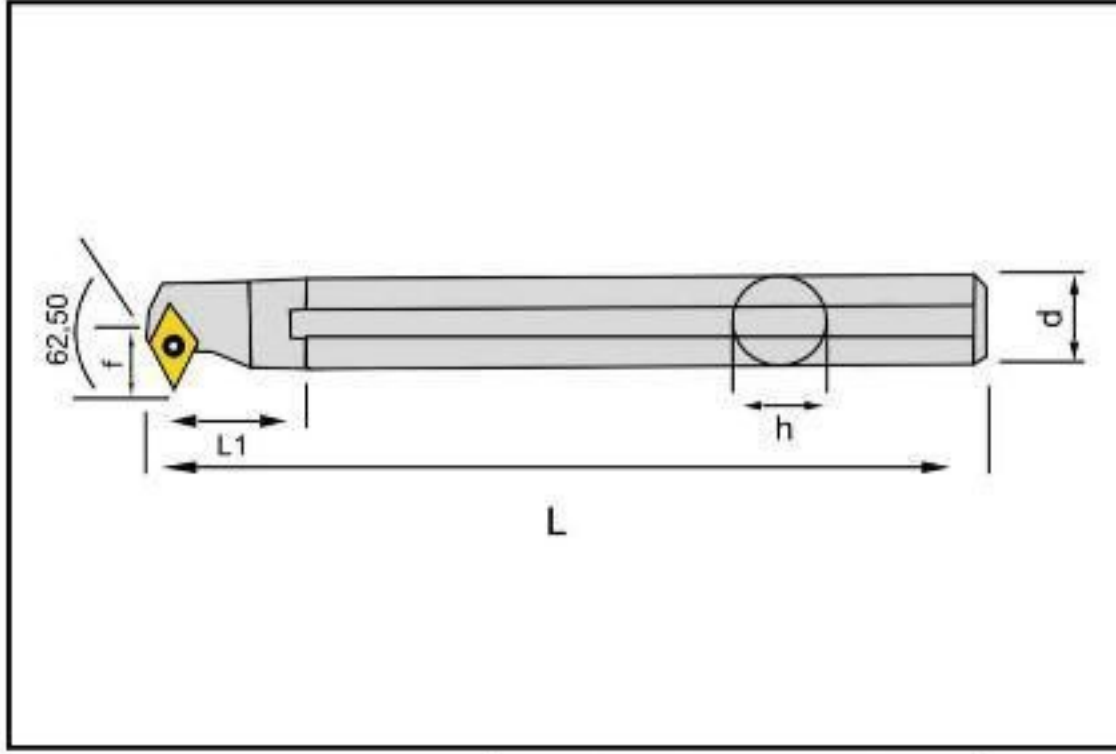

KOD CODE	ÖLÇÜLER DIMENSION (mm)					KESİCİ UÇ INSERT	YEDEK PARÇALAR SPARE PARTS			
	h	b	L	f	D min		Sıkma Vidası Clamp Screw	Altık Shim	Altık Vidası Shim Screw	Anahtar Torx Key
SD-CR/L										
S12K SD-CR/L-07	12	11	125	09	≥17	DCM 07 02..	SSV M2,5X7,5	-	-	T08
S16P SD-CR/L-11	16	15	170	11	≥21	DCM 11 T3..	SSV M3,5X11	-	-	T15
S20R SD-CR/L-11	20	18	200	13	≥25		SSV M3,5X14	BAX-DC11	SBV-M5.05 A3,5x11	
S25S SD-CR/L-11	25	23	250	17	≥32					
S32T SD-CR/L-11	32	30	300	22	≥40					
S40U SD-CR/L-11	40	37	350	27	≥50					
S12K 16X12 SD-CR/L-07	16	15	150	09	≥17	DCM 07 02..	SSV M2,5X7,5	-	-	T08

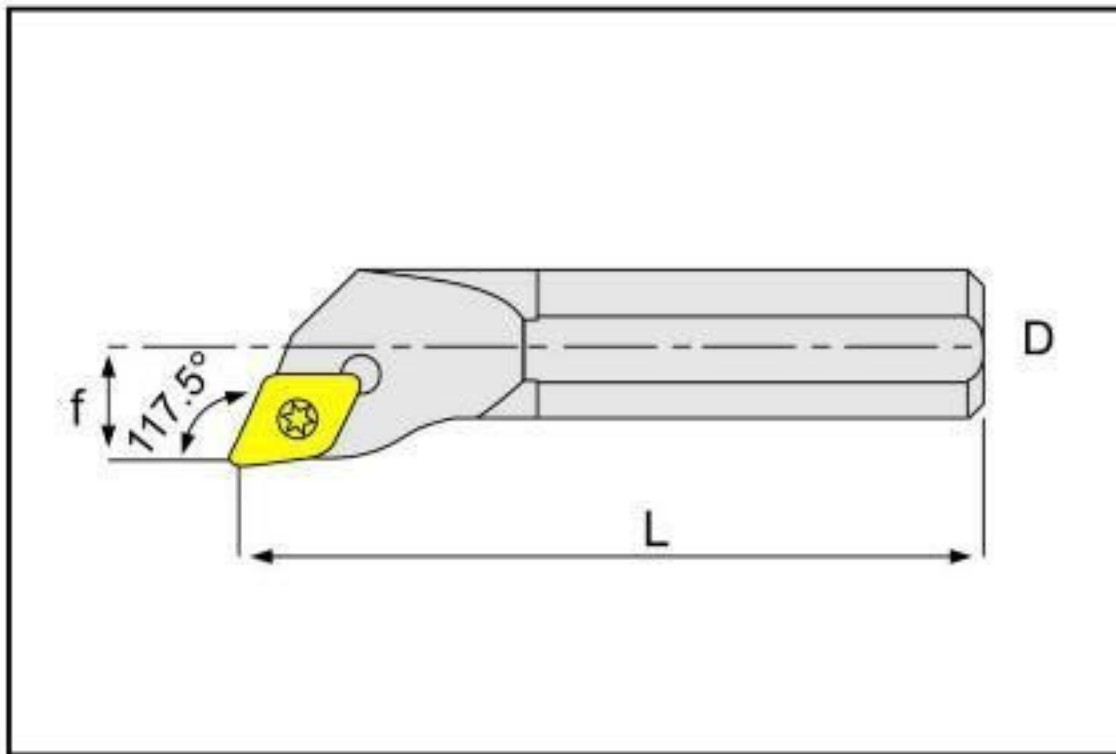

KOD CODE	ÖLÇÜLER DIMENSION (mm)					KESİCİ UÇ INSERT	YEDEK PARÇALAR SPARE PARTS			
	h	b	L	f	D min		Sıkma Vidası Clamp Screw	Altık Shim	Altık Vidası Shim Screw	Anahtar Torx Key
SDPCR/L										
S10K SDPCR/L-07	10	09	125	07	≥23	DCM 07 02..	SSV M2,5X7,5	-	-	T08
S12K SDPCR/L-07	12	11	125	09	≥16		SSV M3,5X11	-	-	
S16P SDPCR/L-11	16	15	170	11	≥21	DCM 11 T3..	SSV M3,5X14	BAX-DC11	SBV-M5.05 A3,5x11	T15
S20R SDPCR/L-11	20	18	200	13	≥25					
S25S SDPCR/L-11	25	23	250	17	≥32					
S32T SDPCR/L-11	32	30	300	22	≥40					
S40U SDPCR/L-11	40	37	350	27	≥50					

S SİSTEM DELİK TORNA KATERLERİ S System Boring Bars

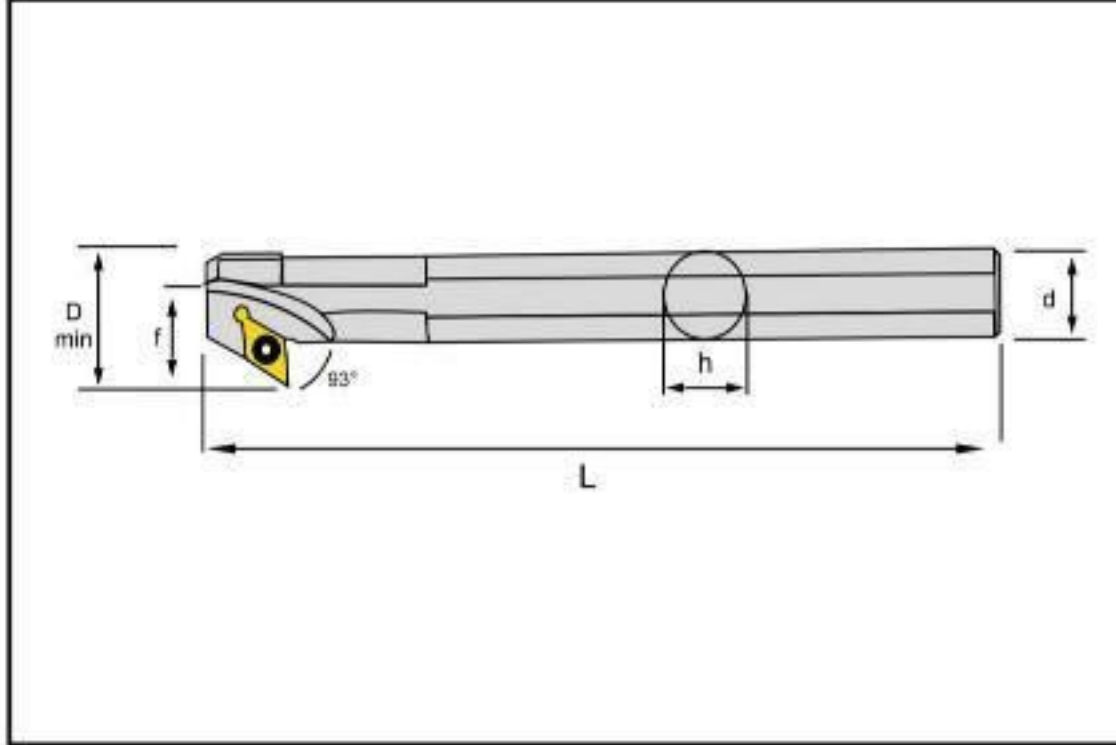

KOD CODE	ÖLÇÜLER DIMENSION (mm)					KESİCİ UÇ INSERT	YEDEK PARÇALAR SPARE PARTS			
	h	b	L	f	D min		Sıkma Vidası Clamp Screw	Altık Shim	Altık Vidası Shim Screw	Anahtar Torx Key
SDXCR/L										
S12K SDXCR/L-07	12	11	125	09	≥17	DCM 07 02..	SSV M2,5X7,5	-	-	T08
S16P SDXCR/L-11	16	15	170	11	≥21	DCM 11 T3..	SSV M3,5X11	-	-	T15
S20R SDXCR/L-11	20	18	200	13	≥25					
S25S SDXCR/L-11	25	23	250	17	≥32					
S32T SDXCR/L-11	32	30	300	22	≥40					
S40U SDXCR/L-11	40	37	350	27	≥50		SSV M3,5X14	BAX- DC11	SBV-M5.05 A3,5x11	

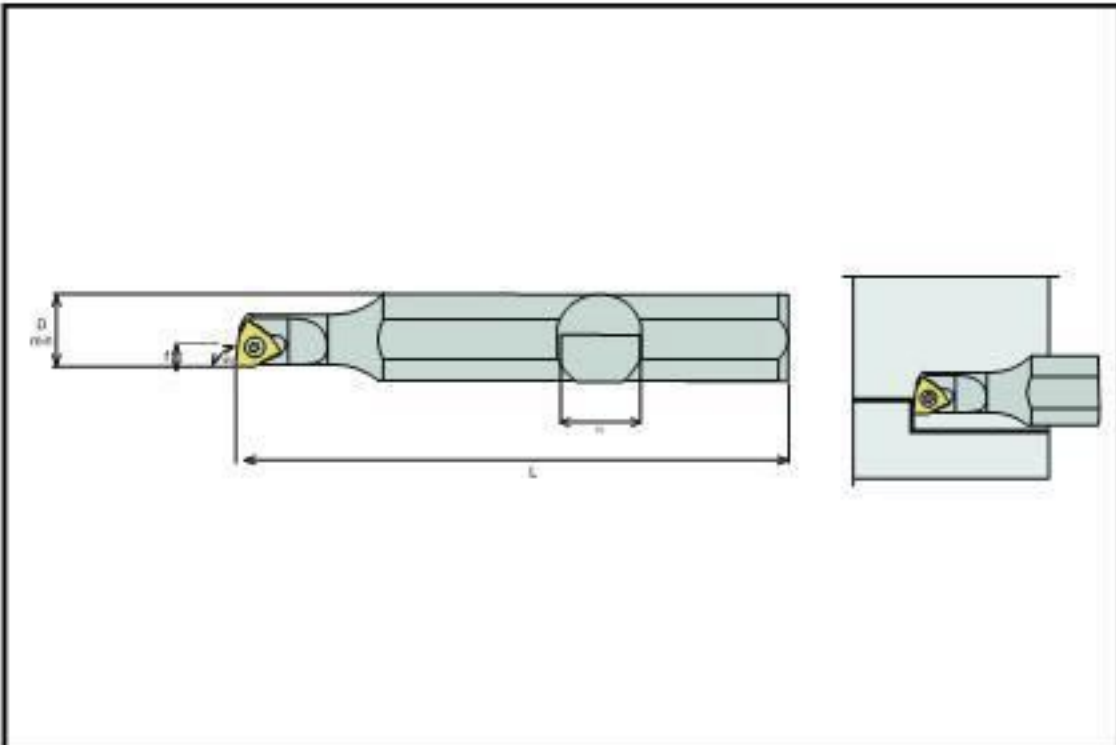

KOD CODE	ÖLÇÜLER DIMENSION (mm)					KESİCİ UÇ INSERT	YEDEK PARÇALAR SPARE PARTS			
	h	b	L	f	D min		Sıkma Vidası Clamp Screw	Altık Shim	Altık Vidası Shim Screw	Anahtar Torx Key
SWLCR										
S0608H SWLCR-03	08	05	100	04	≥08	WCM. 03 02 ..	SSV M2,5X7,5	-	-	T08
S0810K SWLCR-03	10	07	125	07	≥10					

S SİSTEM DELİK TORNA KATERLERİ

S System Boring Bars

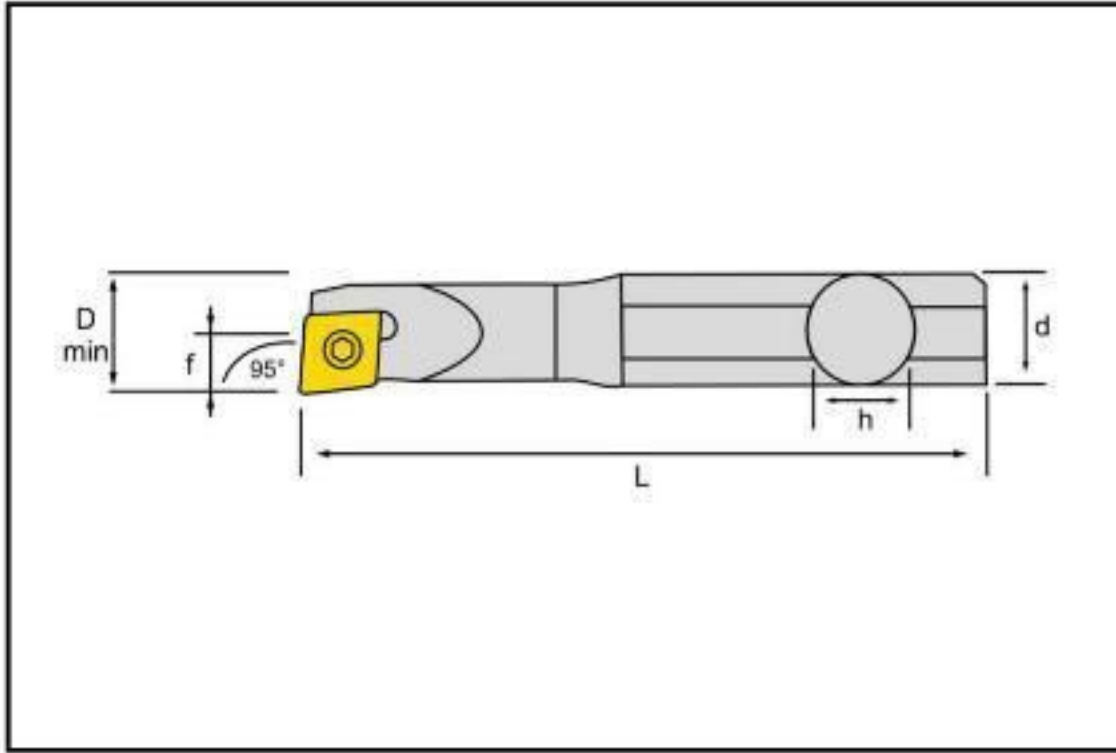

KOD CODE	ÖLÇÜLER DIMENSION (mm)					KESİCİ UÇ INSERT	YEDEK PARÇALAR SPARE PARTS			
	h	b	L	f	D min		Sıkma Vidası Clamp Screw	Altık Shim	Altık Vidası Shim Screw	Anahtar Torx Key
SCLCR/L										
S0608H SCLCR/L-06	06	7	100	4,5	≥8	CCM.06 02..		-	-	T08
S08H SCLCR/L-06	08	7	100	06	≥11					
S10K SCLCR/L-06	10	9	125	07	≥13					
S12K SCLCR/L-06	12	11	125	09	≥16	CCM.09 T3..		-	-	T15
S16P SCLCR/L-09	16	15	170	11	≥21					
S20R SCLCR/L-09	20	19	200	13	≥25					
S25S SCLCR/L-09	25	23	250	17	≥32					
S32T SCLCR/L-09	32	30	300	22	≥40	CCM.12 04..		BAX-CC09	SBV-M5.05 A3,5x11	T15
S32T SCLCR/L-12	32	30	300	22	≥40					
S40U SCLCR/L-12	40	37	350	27	≥50					

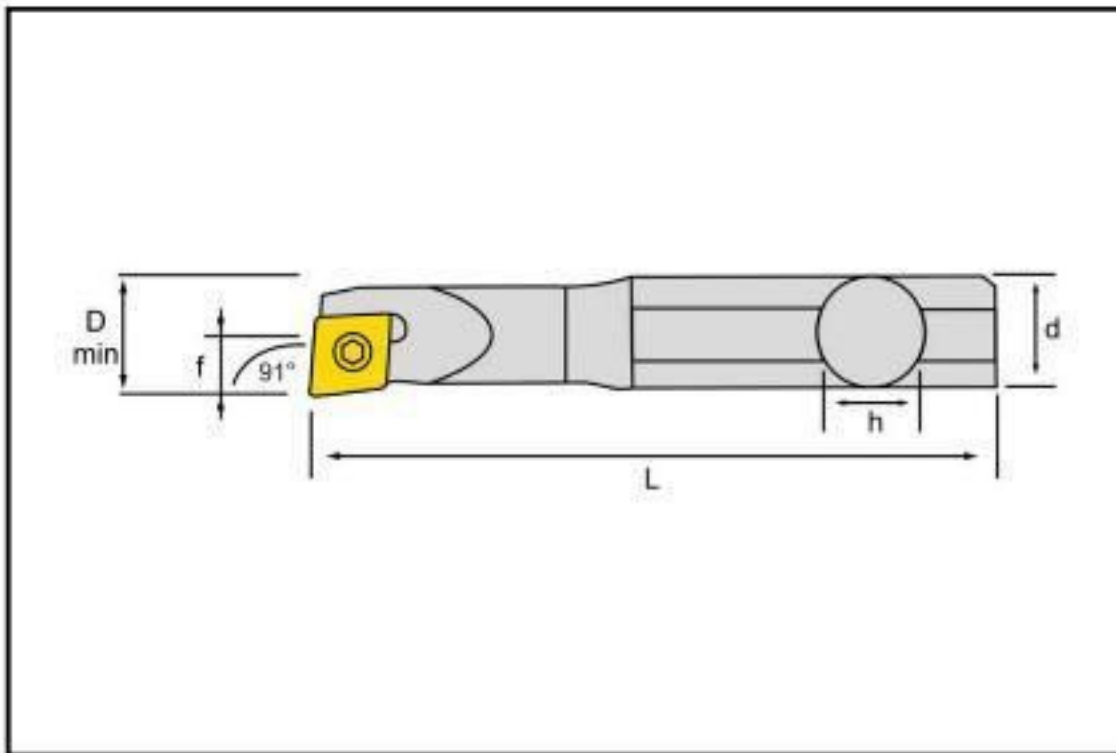

KOD CODE	ÖLÇÜLER DIMENSION (mm)					KESİCİ UÇ INSERT	YEDEK PARÇALAR SPARE PARTS			
	h	b	L	f	D min		Sıkma Vidası Clamp Screw	Altık Shim	Altık Vidası Shim Screw	Anahtar Torx Key
SCFCR/L										
S08H SCFCR/L-06	08	7	100	06	≥11	CCM.06 02..		-	-	T08
S10K SCFCR/L-06	10	9	125	07	≥13					
S12K SCFCR/L-06	12	11	125	09	≥16					
S16P SCFCR/L-09	16	15	170	11	≥21	CCM.09 T3..		-	-	T15
S20R SCFCR/L-09	20	19	200	13	≥25					
S25S SCFCR/L-09	25	23	250	17	≥32					
S25S SCFCR/L-12	25	23	250	17	≥32					
S32T SCFCR/L-12	32	30	300	22	≥40	CCM.12 04..		BAX-CC12	SBV-M5.05 A4.5x11	T15
S40U SCFCR/L-12	40	37	350	27	≥50					

S SİSTEM DELİK TORNA KATERLERİ S System Boring Bars

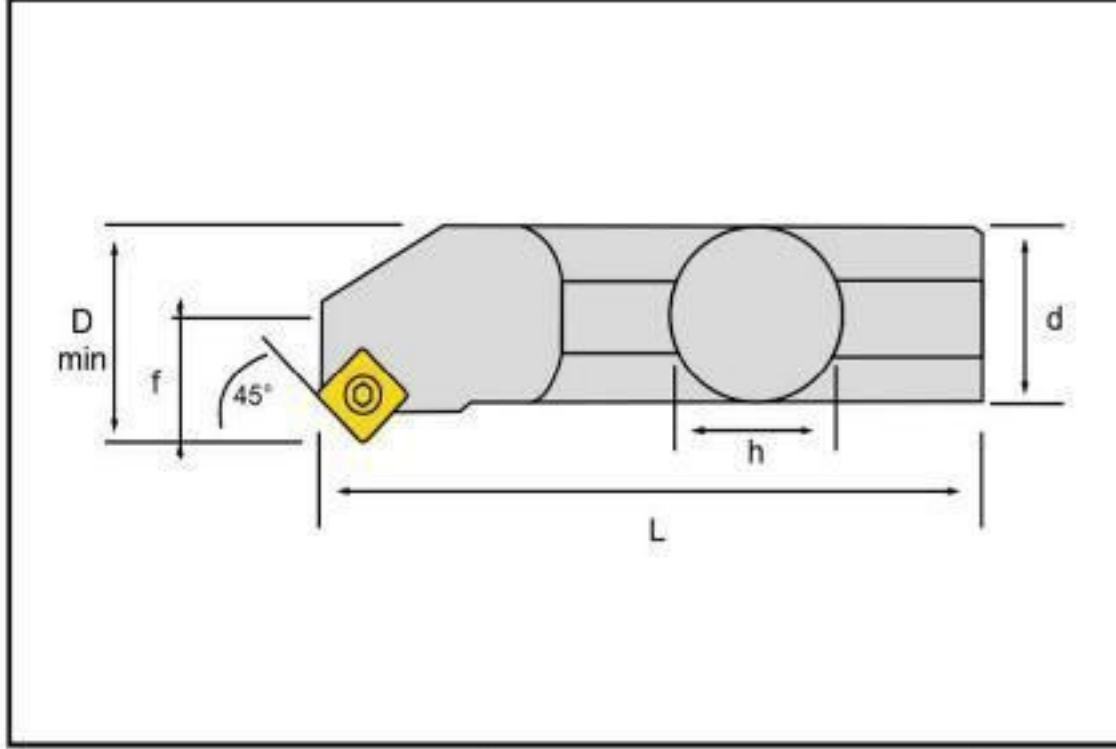

KOD CODE	ÖLÇÜLER DIMENSION (mm)					KESİCİ UÇ INSERT	YEDEK PARÇALAR SPARE PARTS			
	h	b	L	f	D min		Sıkma Vidası Clamp Screw	Altık Shim	Altık Vidası Shim Screw	Anahtar Torx Key
SSSCR/L										
S16P SSSCR/L-09	16	15	170	11	≥21	SCM.09 T3..	SSV M3,5X11	-	-	T15
S20R SSSCR/L-09	20	18	200	13	≥25		SSV M3,5X14	BAX-SC09	SBV-M5.05 A3,5x11	
S25S SSSCR/L-09	25	23	250	17	≥32		SSV M4X16	BAX-SC12	SBV-M5.05 A4,5x11	
S32T SSSCR/L-12	32	30	300	22	≥40	SCM.12 04..				T20
S40U SSSCR/L-12	40	37	350	27	≥50					

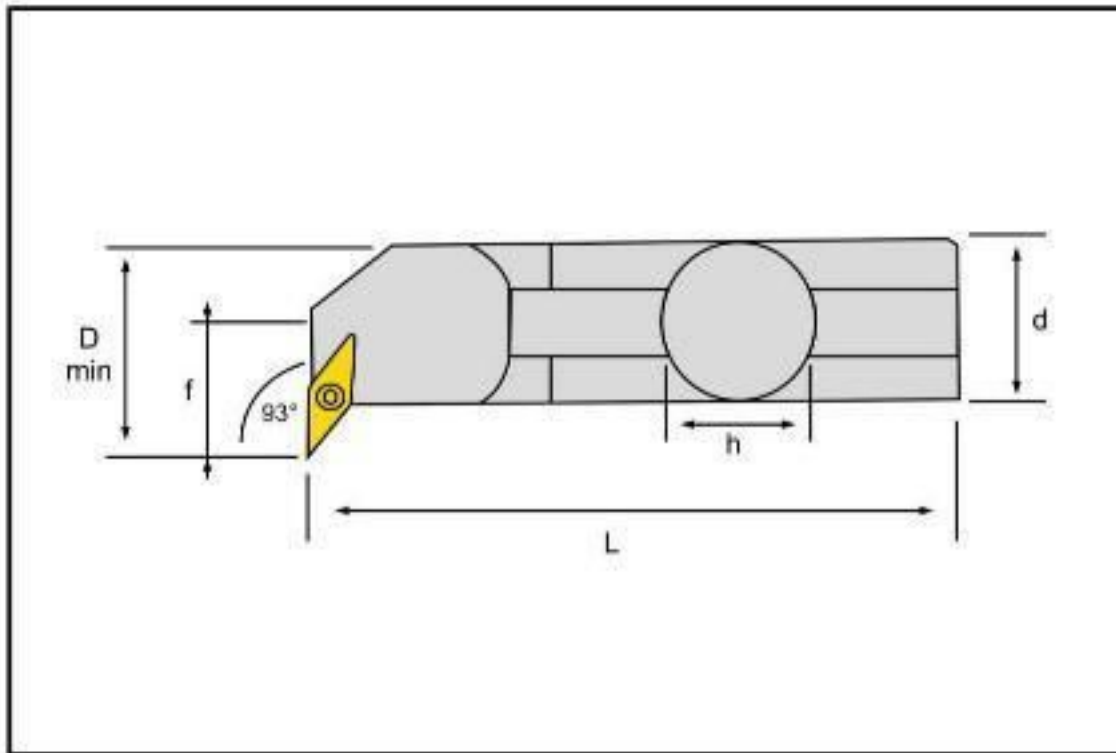

KOD CODE	ÖLÇÜLER DIMENSION (mm)					KESİCİ UÇ INSERT	YEDEK PARÇALAR SPARE PARTS			
	h	b	L	f	D min		Sıkma Vidası Clamp Screw	Altık Shim	Altık Vidası Shim Screw	Anahtar Torx Key
SVUBR/L										
S16P SVUBR/L-11	16	15	170	11	≥21	VBM. 11 03..	SSV M2,5X7,5	-	-	T08
S20R SVUBR/L-11	20	18	200	13	≥25		SSV M3,5X14	BAX-VB16	SBV-M5.05 A3,5x11	
S25S SVUBR/L-16	25	23	250	17	≥32					
S32T SVUBR/L-16	32	30	300	22	≥40	VBM. 16 04..				T15
S40U SVUBR/L-16	40	37	350	27	≥50					

S SİSTEM DELİK TORNA KATERLERİ S System Boring Bars

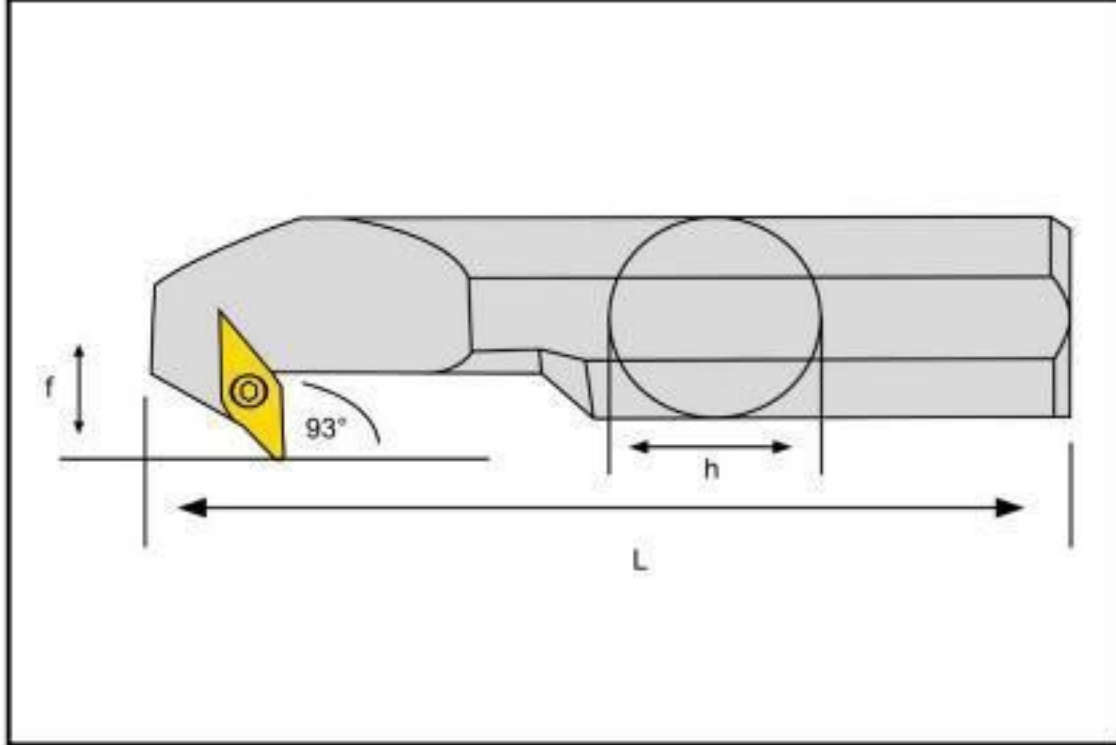

KOD CODE	ÖLÇÜLER DIMENSION (mm)					KESİCİ UÇ INSERT	YEDEK PARÇALAR SPARE PARTS			
	h	b	L	f	D min		Sıkma Vidası Clamp Screw	Altlık Shim	Altlık Vidası Shim Screw	Anahtar Torx Key
SVXBR/L										
S16P SVXBR/L-11	16	15	170	11	≥21	VBM. 11 03..	SSV M2,5X7,5	-	-	T08
S20R SVXBR/L-11	20	18	200	13	≥25					
S25S SVXBR/L-16	25	23	250	17	≥32	VBM. 16 04..	SSV M3,5X14	BAX- VB16	SBV-M5.05 A3,5x11	T15
S32T SVXBR/L-16	32	30	300	22	≥40					
S40U SVXBR/L-16	40	37	350	27	≥50					

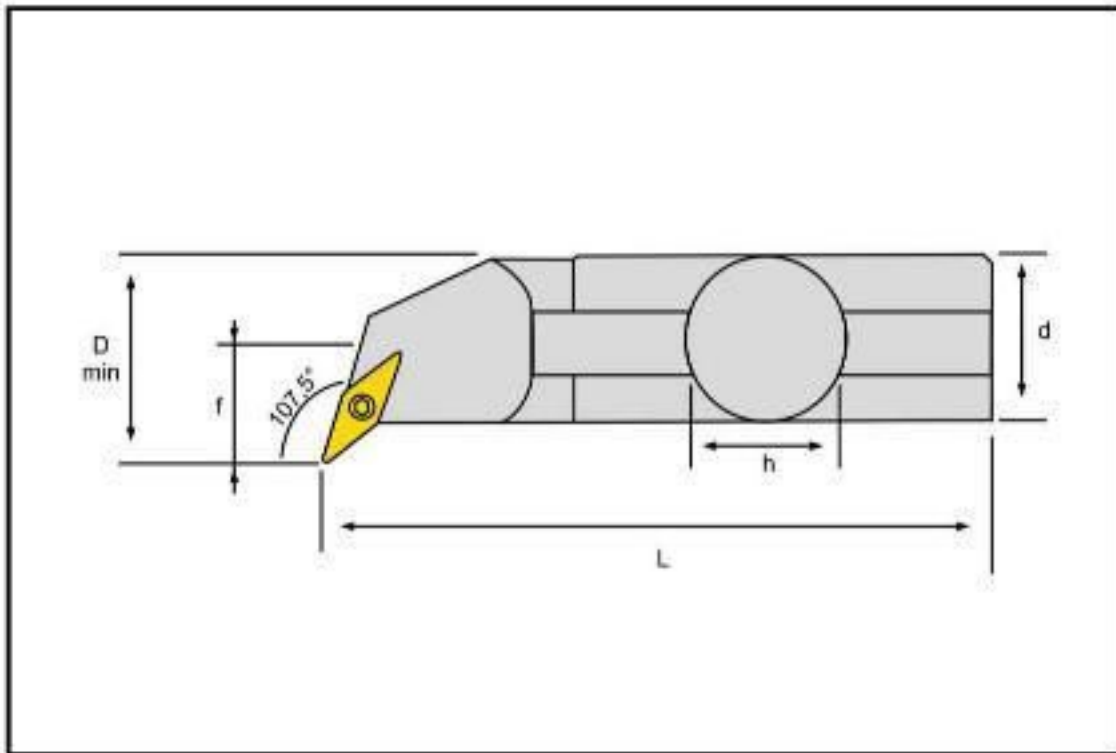

KOD CODE	ÖLÇÜLER DIMENSION (mm)					KESİCİ UÇ INSERT	YEDEK PARÇALAR SPARE PARTS			
	h	b	L	f	D min		Sıkma Vidası Clamp Screw	Altlık Shim	Altlık Vidası Shim Screw	Anahtar Torx Key
SVQBR/L										
S16P SVQBR/L-11	16	15	170	11	≥21	VBM. 11 03..	SSV M2,5X7,5	-	-	T08
S20R SVQBR/L-11	20	18	200	13	≥25					
S25S SVQBR/L-16	25	23	250	17	≥32	VBM. 16 04..	SSV M3,5X14	BAX- VB16	SBV-M5.05 A3,5x11	T15
S32T SVQBR/L-16	32	30	300	22	≥40					
S40U SVQBR/L-16	40	37	350	27	≥50					

S SİSTEM DELİK TORNA KATERLERİ S System Boring Bars

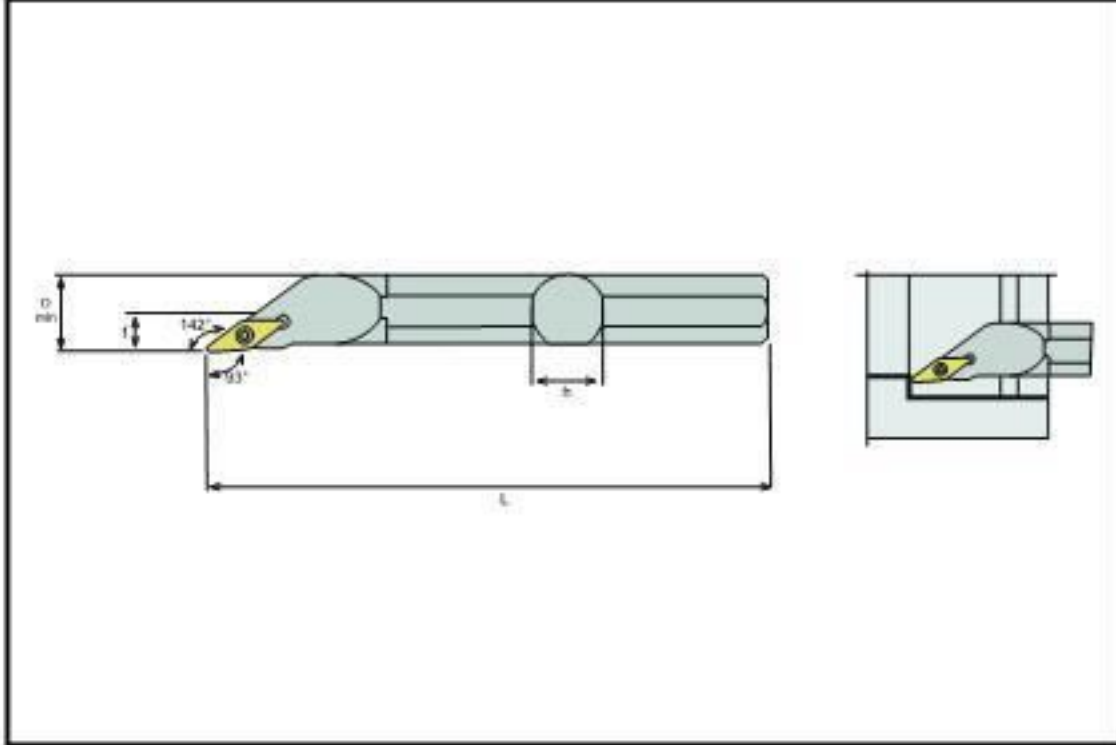

KOD CODE	ÖLÇÜLER DIMENSION (mm)					KESİCİ UÇ INSERT	YEDEK PARÇALAR SPARE PARTS			
	h	b	L	f	D min		Sıkma Vidası Clamp Screw	Altık Shim	Altık Vidası Shim Screw	Anahtar Torx Key
SVJBR/L										
S25S SVJBR/L-16	25	23	250	17	≥32	VBM. 16 04..	SSV M3,5X14	BAX- VB16	SBV-M5.05 A3,5x11	T15
S32T SVJBR/L-16	32	30	300	22	≥40					
S40U SVJBR/L-16	40	37	350	27	≥50					

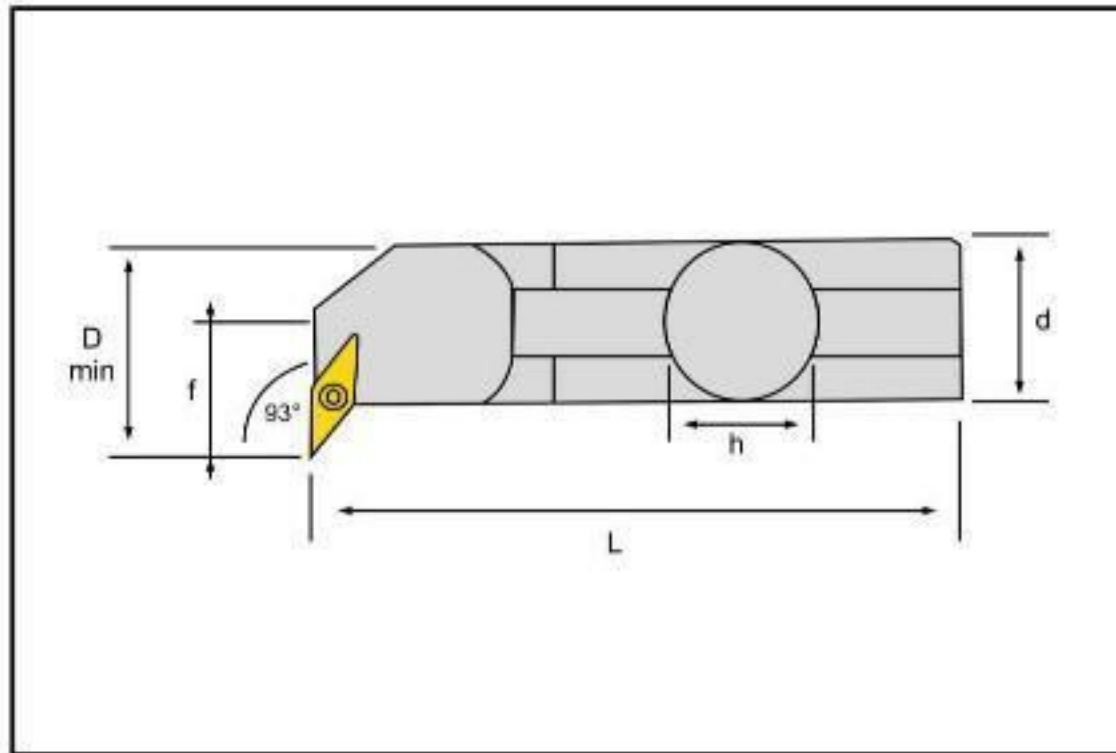

KOD CODE	ÖLÇÜLER DIMENSION (mm)					KESİCİ UÇ INSERT	YEDEK PARÇALAR SPARE PARTS			
	h	b	L	f	D min		Sıkma Vidası Clamp Screw	Altık Shim	Altık Vidası Shim Screw	Anahtar Torx Key
SVUCR/L										
S16P SVUCR/L-11	16	15	170	11	≥21	VCM. 11 03..	SSV M2,5X7,5	-	-	T08
S20R SVUCR/L-11	20	18	200	13	≥25					
S25S SVUCR/L-16	25	23	250	17	≥32	VCM. 16 04..	SSV M3,5X14	BAX- VC16	SBV-M5.05 A3,5x11	T15
S32T SVUCR/L-16	32	30	300	22	≥40					
S40U SVUCR/L-16	40	37	350	27	≥50					

S SİSTEM DELİK TORNA KATERLERİ

S System Boring Bars

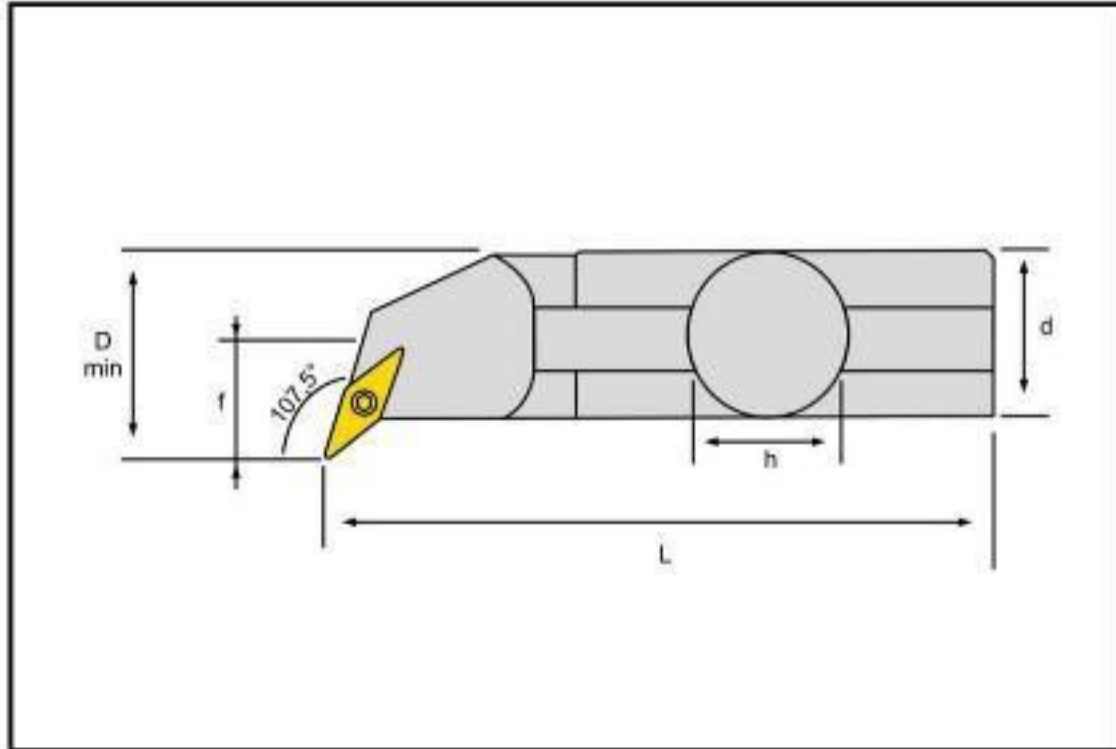

KOD CODE	ÖLÇÜLER DIMENSION (mm)					KESİCİ UÇ INSERT	YEDEK PARÇALAR SPARE PARTS			
	h	b	L	f	D min		Sıkma Vidası Clamp Screw	Altık Shim	Altık Vidası Shim Screw	Anahtar Torx Key
SVQCR/L										
S16P SVQCR/L-11	16	15	170	11	≥21	VCM. 11 03..	SSV M2,5X7,5	-	-	T08
S20R SVQCR/L-11	20	18	200	13	≥25					
S25S SVQCR/L-16	25	23	250	17	≥32	VCM. 16 04..	SSV M3,5X14	BAX- VC16	SBV-M5.05 A3,5x11	T15
S32T SVQCR/L-16	32	30	300	22	≥40					
S40U SVQCR/L-16	40	37	350	27	≥50					

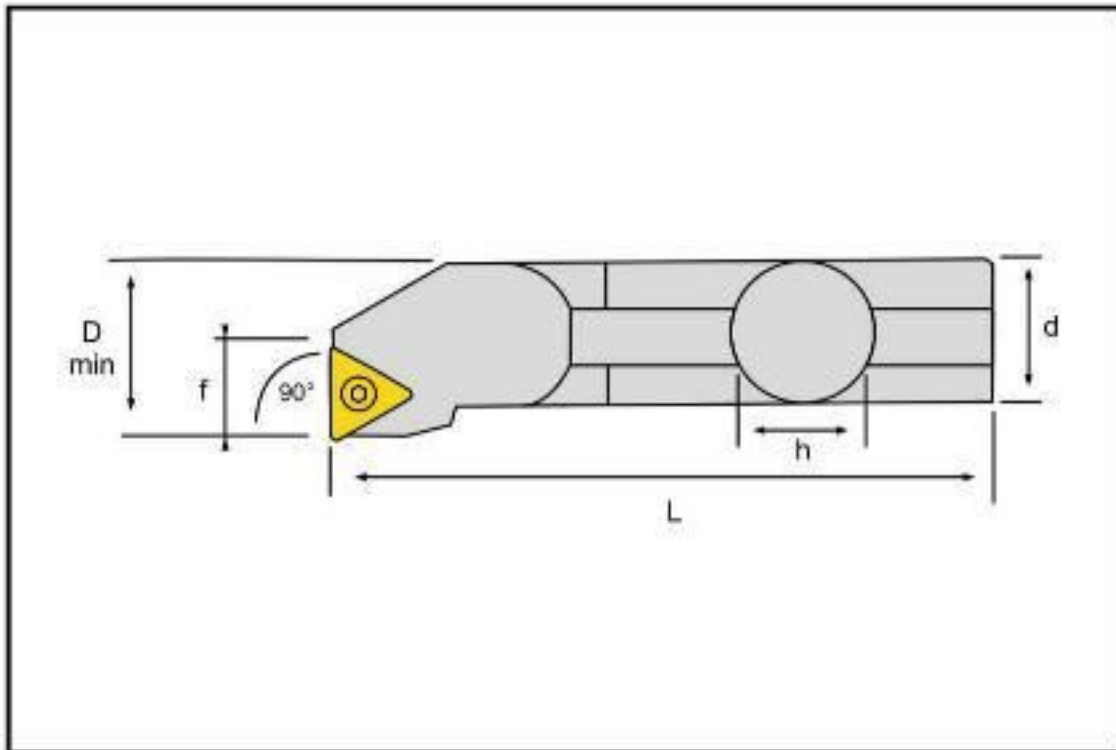

KOD CODE	ÖLÇÜLER DIMENSION (mm)					KESİCİ UÇ INSERT	YEDEK PARÇALAR SPARE PARTS			
	h	b	L	f	D min		Sıkma Vidası Clamp Screw	Altık Shim	Altık Vidası Shim Screw	Anahtar Torx Key
STUCR/L										
S10K STUCR/L-09	10	09	125	07	≥13	TCM.09 02..	SSV M2,2X5	-	-	T07
S12K STUCR/L-09	12	11	125	09	≥17					
S12K STUCR/L-11	12	11	125	09	≥17	TCM.11 02..	SSV M2,5X7,5	-	-	T08
S16P STUCR/L-11	16	15	170	11	≥21					
S20R STUCR/L-11	20	18	200	13	≥25	TCM. 16 T3.	SSV M3,5X11	-	-	T15
S16P STUCR/L-16	16	15	170	11	≥21					
S20R STUCR/L-16	20	18	200	13	≥25					
S25S STUCR/L-16	25	23	250	17	≥32					
S32T STUCR/L-16	32	30	300	22	≥40					
S40U STUCR/L-16	40	37	350	27	≥50	SSV M3,5X14	BAX- TC16	SBV-M5.05 A3,5x11	T15	

S SİSTEM DELİK TORNA KATERLERİ S System Boring Bars

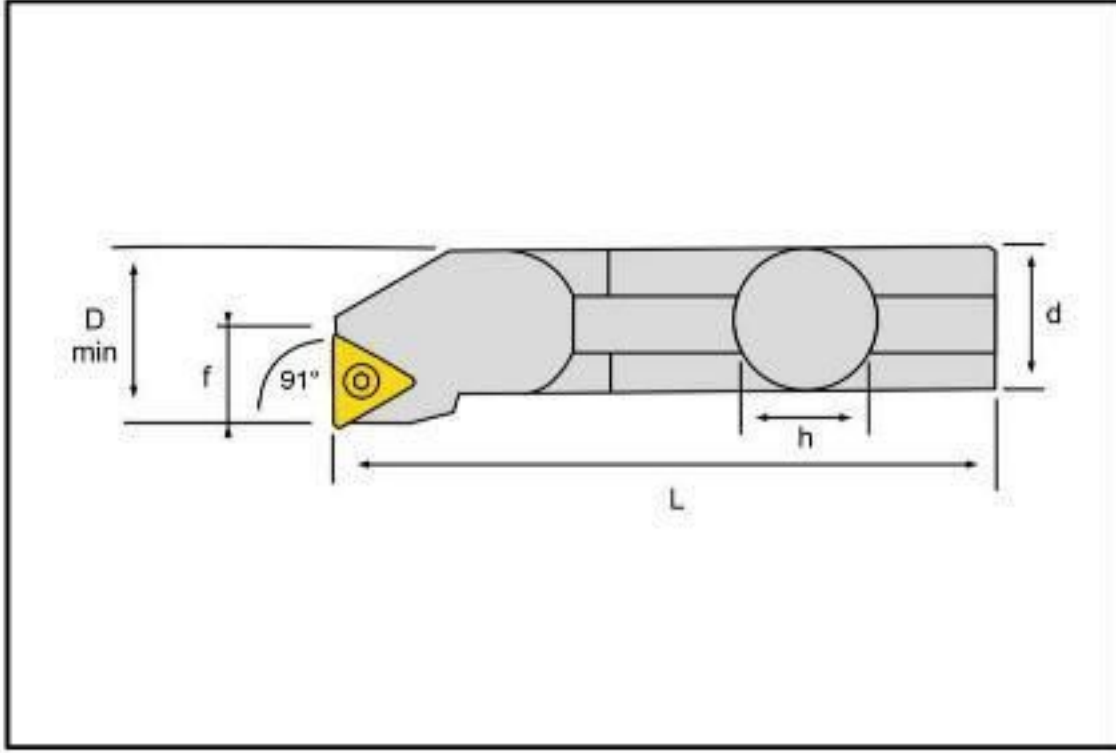

KOD CODE	ÖLÇÜLER DIMENSION (mm)					KESİCİ UÇ INSERT	YEDEK PARÇALAR SPARE PARTS			
	h	b	L	f	D min		Sıkma Vidası Clamp Screw	Altk Shim	Altk Vidası Shim Screw	Anahtar Torx Key
STFCR/L										
S0610F STFCR/L-06	10	09	125	04	≥08	TCM.06T1	SSV M2x4	-	-	T06
S10K STFCR/L-09	10	09	125	07	≥13	TCM.09 02..	SSV M2,2X7,5	-	-	T07
S12K STFCR/L-09	12	11	125	09	≥17					
S12K STFCR/L-11	12	11	125	09	≥17	TCM.11 02..	SSV M2,5X7,5	-	-	T08
S16P STFCR/L-11	16	15	170	11	≥21					
S20R STFCR/L-11	20	18	200	13	≥25	TCM. 16 T3..	SSV M3,5X11	-	-	T15
S16P STFCR/L-16	16	15	170	11	≥21					
S20R STFCR/L-16	20	18	200	13	≥25					
S25S STFCR/L-16	25	23	250	17	≥32					
S32T STFCR/L-16	32	30	300	22	≥40					
S40U STFCR/L-16	40	37	350	27	≥50		SSV M3,5X14	BAX- TC16	SBV-M5.05 A3,5x11	

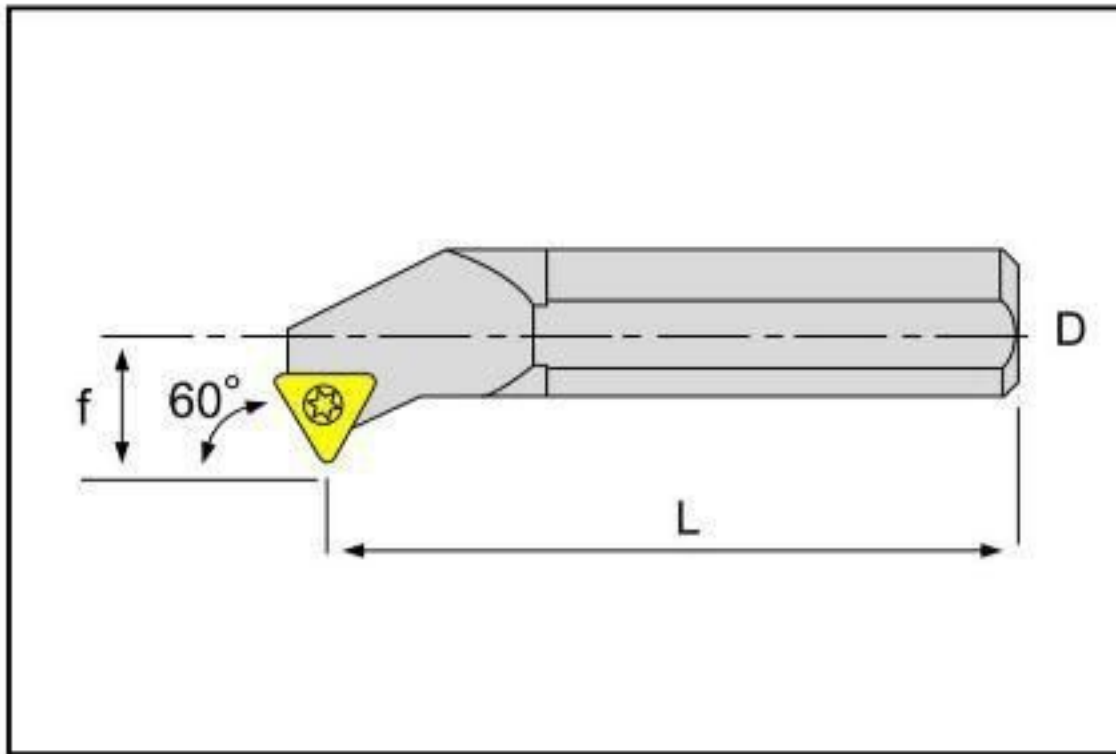

KOD CODE	ÖLÇÜLER DIMENSION (mm)					KESİCİ UÇ INSERT	YEDEK PARÇALAR SPARE PARTS			
	h	b	L	f	D min		Sıkma Vidası Clamp Screw	Altk Shim	Altk Vidası Shim Screw	Anahtar Torx Key
ST-CR/L										
S12K ST-CR/L-09	12	11	125	09	≥17	TCM.11 02..	SSV M2,5X7,5	-	-	T08
S12K ST-CR/L-11	12	11	125	09	≥17					
S16P ST-CR/L-11	16	15	170	11	≥21	TCM. 16 T3..	SSV M3,5X11	-	-	T15
S20R ST-CR/L-11	20	18	200	13	≥25					
S16P ST-CR/L-16	16	15	170	11	≥21					
S20R ST-CR/L-16	20	18	200	13	≥25					
S25S ST-CR/L-16	25	23	250	17	≥32					
S32T ST-CR/L-16	32	30	300	22	≥40		SSV M3,5X14	BAX- TC16	SBV-M5.05 A3,5x11	
S40U ST-CR/L-16	40	37	350	27	≥50					

DIŞ ÇAP KANAL AÇMA TAKIMLARI

EXTERNAL GROOVING TOOLHOLDERS



DIŞ ÇAP KANAL AÇMA TAKIMLARI External Grooving Toolholders

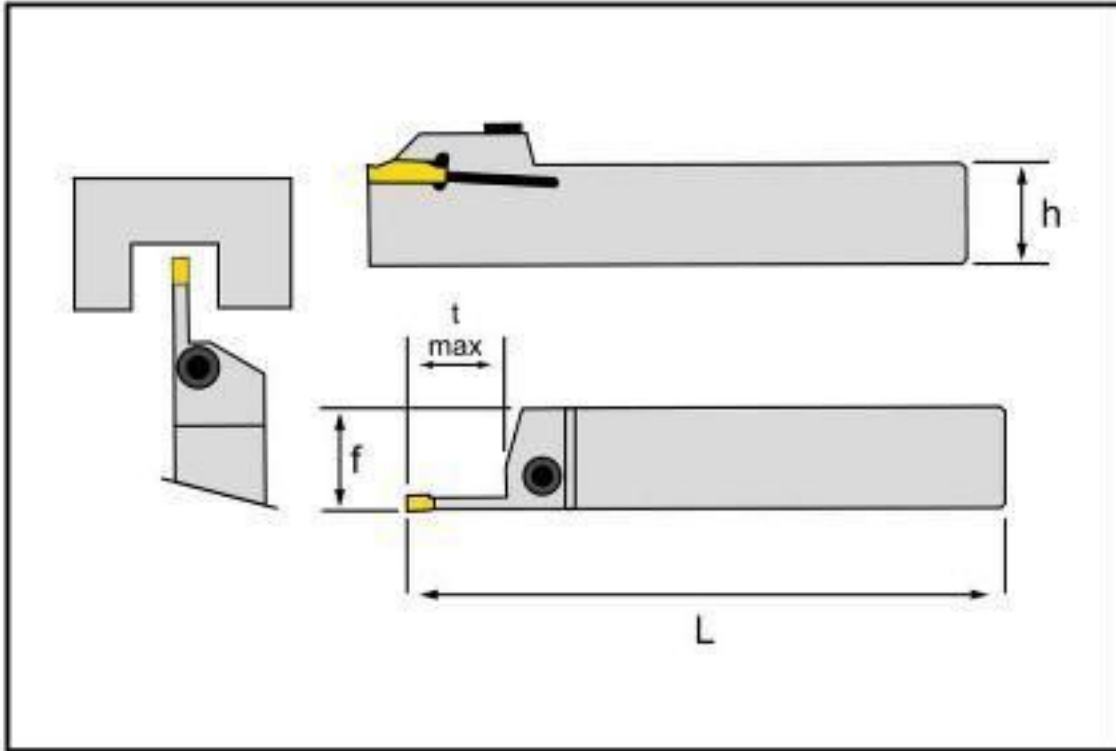

KOD CODE	ÖLÇÜLER DIMENSION (mm)					KESİCİ UÇ INSERT	YEDEK PARÇALAR SPARE PARTS			
	h	B	L	S	t_max		Sıkma Vidası Clamp Screw	Pul Stamp	Anahtar Allen Key	
BDKT R/L KORLOY										
1212 BDKT R/L -K2C	12	12	100	12,3	15	KRLY 2C	BKTV M5X12	-	AA4	
1616 BDKT R/L -K2C	16	16	100	16,3	15		BKTV M6x25	-	AA5	
2020 BDKT R/L -K2C	20	20	125	20,3	15		BKTV M5x12	-	AA4	
2525 BDKT R/L -K2C	25	25	150	25,3	15		KRLY 3C	BKTV M6x25	-	AA5
3232 BDKT R/L -K2C	32	32	170	32,3	15					
1212 BDKT R/L -K3C	12	12	100	12,3	15					
1616 BDKT R/L -K3C	16	16	100	16,4	15					
2020 BDKT R/L -K3C	20	20	125	20,4	20					
2525 BDKT R/L -K3C	25	25	150	25,4	22	KRLY 4C	BKTV M6x25	-	AA5	
3232 BDKT R/L -K3C	32	32	170	32,4	22					
2020 BDKT R/L -K4C	20	20	125	20,4	20					
2525 BDKT R/L -K4C	25	25	150	25,4	22	KRLY 5C	BKTV M6x25	-	AA5	
3232 BDKT R/L -K4C	32	32	170	32,4	22					
2020 BDKT R/L -K5C	20	20	125	20,5	20	KRLY 6C	BKTV M6x25	-	AA5	
2525 BDKT R/L -K5C	25	25	150	25,5	25					
3232 BDKT R/L -K5C	32	32	170	32,5	25	KRLY 8C	BKTV M6x25	-	AA5	
2525 BDKT R/L -K6C	25	25	150	25,6	25					
3232 BDKT R/L -K6C	32	32	170	32,6	25					
3232 BDKT R/L -K8C	32	32	170	32,8	32					



DIŞ ÇAP KANAL AÇMA TAKIMLARI External Grooving Toolholders

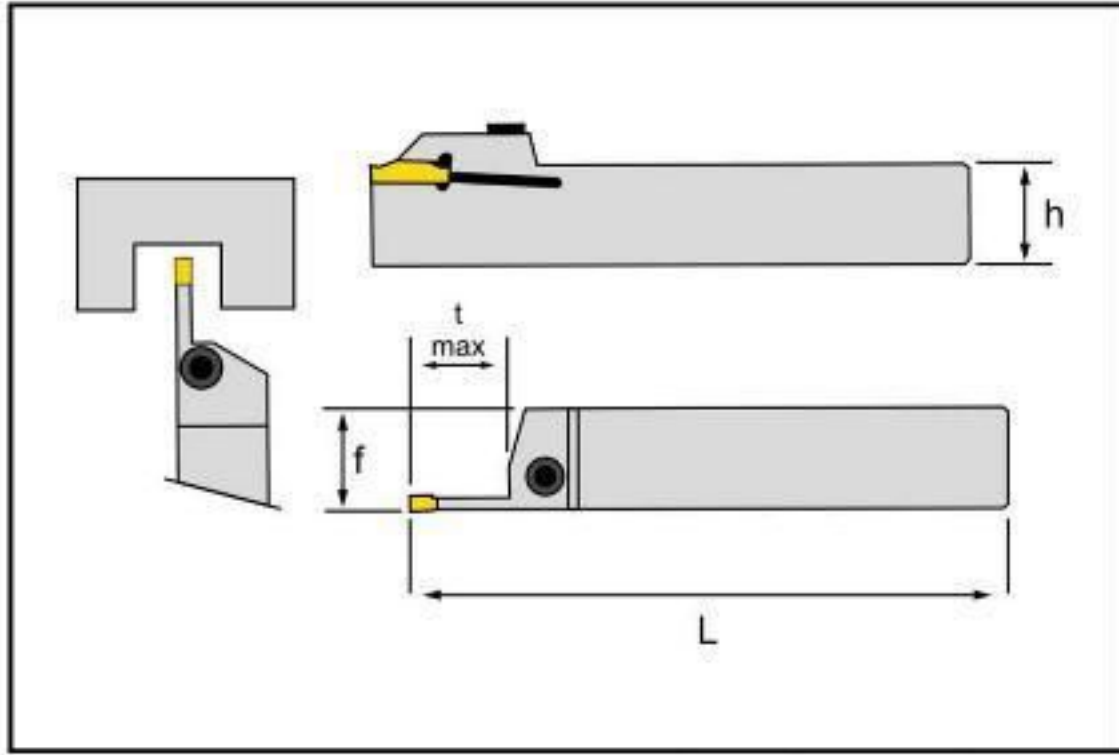

KOD CODE	ÖLÇÜLER DIMENSION (mm)					KESİCİ UÇ INSERT	YEDEK PARÇALAR SPARE PARTS		
	h	B	L	S	t max		Sıkma Vidası Clamp Screw	Pul Stamp	Anahtar Allen Key
BDKT R/L ISCAR									
1212 BDKT R/L -I2C	12	12	100	12,3	15	ISCAR -2C	BKTV M5X12	-	AA4
1616 BDKT R/L -I2C	16	16	100	16,3	15		BKTV M6x25	-	AA5
2020 BDKT R/L -I2C	20	20	125	20,3	15		BKTV M5x12	-	AA4
2525 BDKT R/L -I2C	25	25	150	25,3	15		BKTV M6x25	-	AA5
1212 BDKT R/L -I3C	12	12	100	12,3	15	ISCAR -3C	BKTV M5x12	-	AA4
1616 BDKT R/L -I3C	16	16	100	16,4	15		BKTV M6x25	-	AA5
2020 BDKT R/L -I3C	20	20	125	20,4	20				
2525 BDKT R/L -I3C	25	25	150	25,4	22				
2020 BDKT R/L -I4C	20	20	125	20,3	20	ISCAR-4C			
2525 BDKT R/L -I4C	25	25	150	25,4	22				

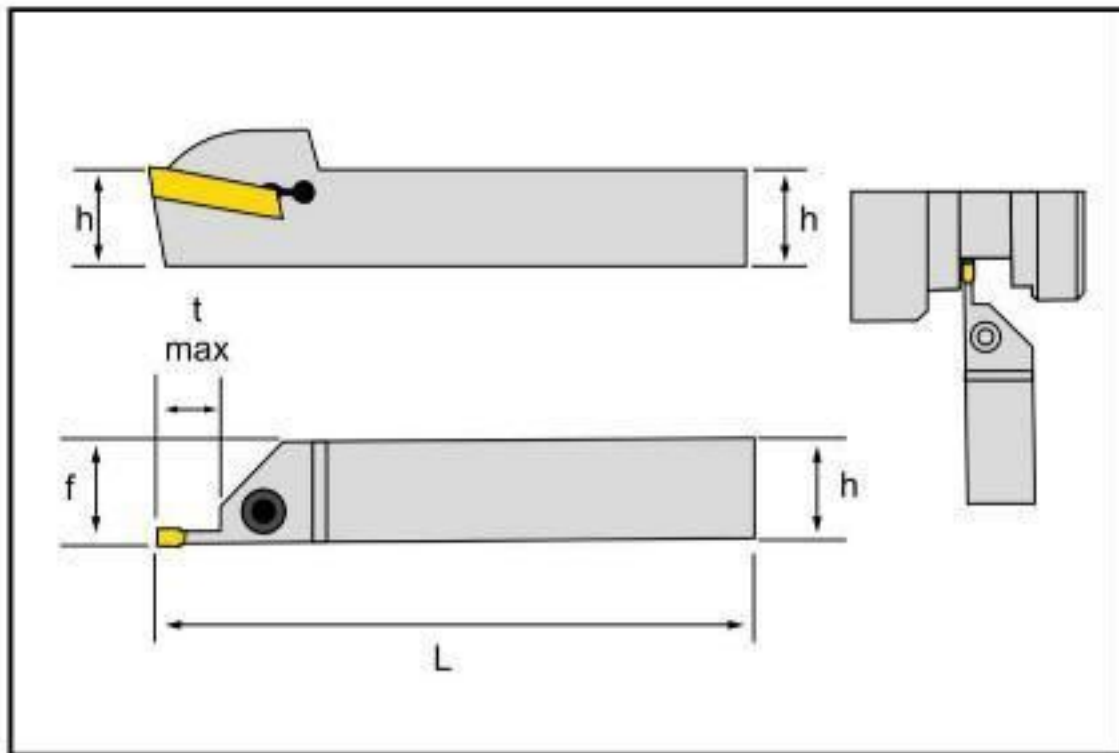

KOD CODE	ÖLÇÜLER DIMENSION (mm)					KESİCİ UÇ INSERT	YEDEK PARÇALAR SPARE PARTS		
	h	B	L	S	t max		Sıkma Vidası Clamp Screw	Pul Stamp	Anahtar Allen Key
BDKT R/L SANDVIK123									
1616 BDKT R/L -SDV123-2C	16	16	100	16,3	15	SDV123-2C			
2020 BDKT R/L -SDV123-2C	20	20	125	20,3	15				
2525 BDKT R/L -SDV123-2C	25	25	150	25,3	15				
1616 BDKT R/L -SDV123-3C	16	16	100	16,4	15	SDV123-3C	BKTV M6x25	-	AA5
2020 BDKT R/L -SDV123-3C	20	20	125	20,4	20				
2525 BDKT R/L -SDV123-3C	25	25	150	25,4	22				
2020 BDKT R/L -SDV123-4C	20	20	125	20,4	20	SDV123-4C			
2525 BDKT R/L -SDV123-4C	25	25	150	25,4	22				
2020 BDKT R/L -SDV123-5C	20	20	125	20,5	20	SDV123-5C			
2525 BDKT R/L -SDV123-5C	25	25	150	25,5	25				

DIŞ ÇAP KANAL AÇMA TAKIMLARI External Grooving Toolholders

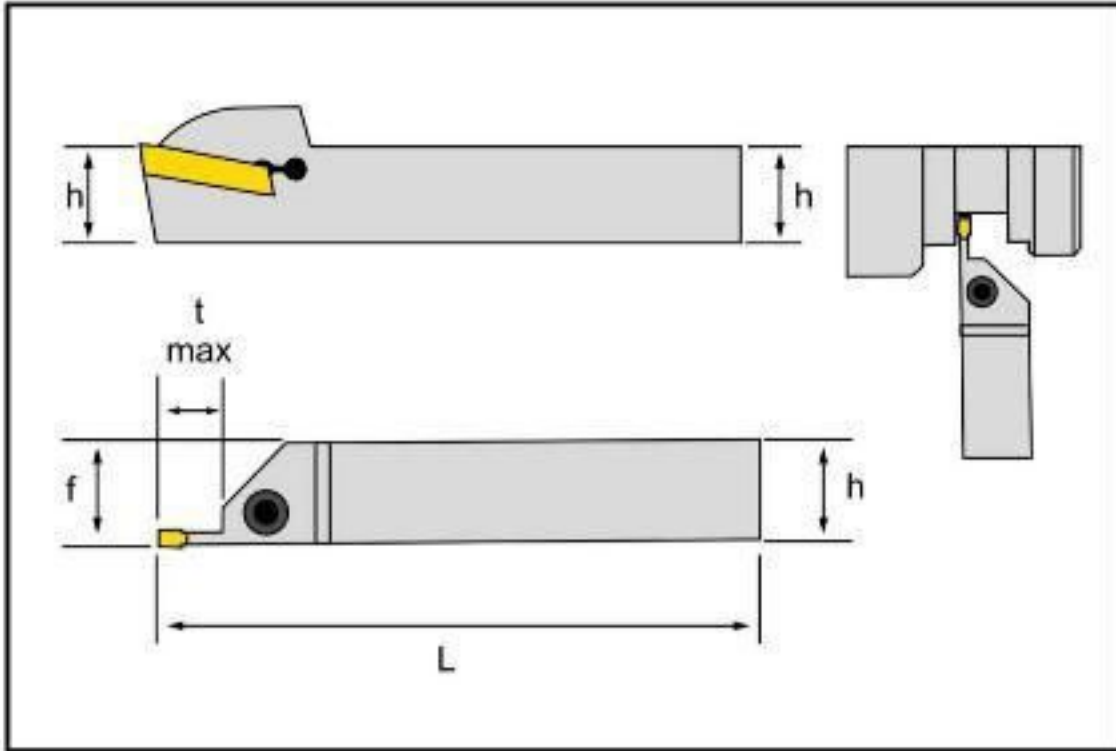

KOD CODE	ÖLÇÜLER DIMENSION (mm)					KESİCİ UÇ INSERT	YEDEK PARÇALAR SPARE PARTS		
	h	B	L	S	t max		Sıkma Vidası Clamp Screw	Pul Stamp	Anahtar Allen Key
BDKT R/L HORN S229									
2020 BDKT R/L -H-S229-2C	20	20	125	20,5	20	HRN S229-2C	BKTV M6x25	-	AA5
2525 BDKT R/L -H-S229-2C	25	25	150	25,5	22				
2020 BDKT R/L -H-S229-3C	20	20	125	20,5	20	HRN S229-3C			
2525 BDKT R/L -H-S229-3C	25	25	150	25,5	22				
2020 BDKT R/L -H-S229-4C	20	20	125	20,5	20	HRN S229-4C			
2525 BDKT R/L -H-S229-4C	25	25	150	25,5	22				
2020 BDKT R/L -H-S229-5C	20	20	125	20,5	20	HRN S229-5C			
2525 BDKT R/L -H-S229-5C	25	25	150	25,5	25				

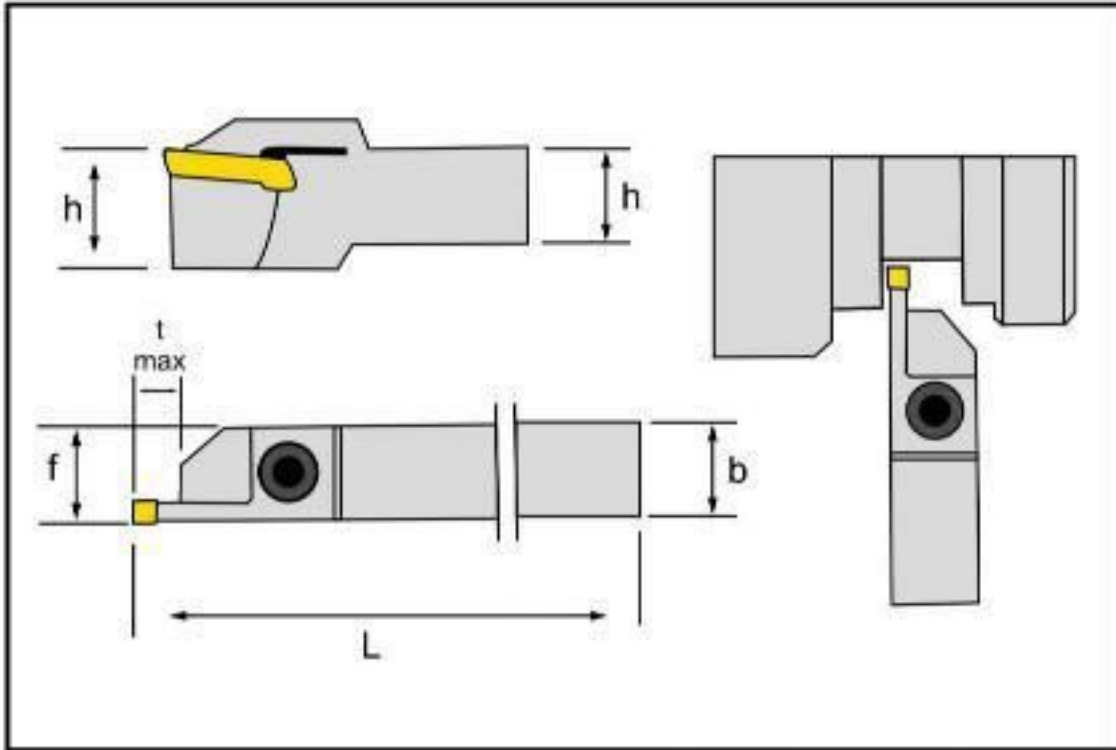

KOD CODE	ÖLÇÜLER DIMENSION (mm)					KESİCİ UÇ INSERT	YEDEK PARÇALAR SPARE PARTS		
	h	B	L	S	t max		Sıkma Vidası Clamp Screw	Pul Stamp	Anahtar Allen Key
BDKT R/L-HORN S224									
2020 BDKT R/L -H-S224-2C	20	20	125	20,3	15	HRN S224-2C	BKTV M6x25	-	AA5
2525 BDKT R/L -H-S224-2C	25	25	150	25,3	15				
2020 BDKT R/L -H-S224-3C	20	20	125	20,4	20	HRN S224-3C			
2525 BDKT R/L -H-S224-3C	25	25	150	25,4	22				
2020 BDKT R/L -H-S224-4C	20	20	125	20,4	20	HRN S224-4C			
2525 BDKT R/L -H-S224-4C	25	25	150	25,4	22				

DIŞ ÇAP KANAL AÇMA TAKIMLARI External Grooving Toolholders

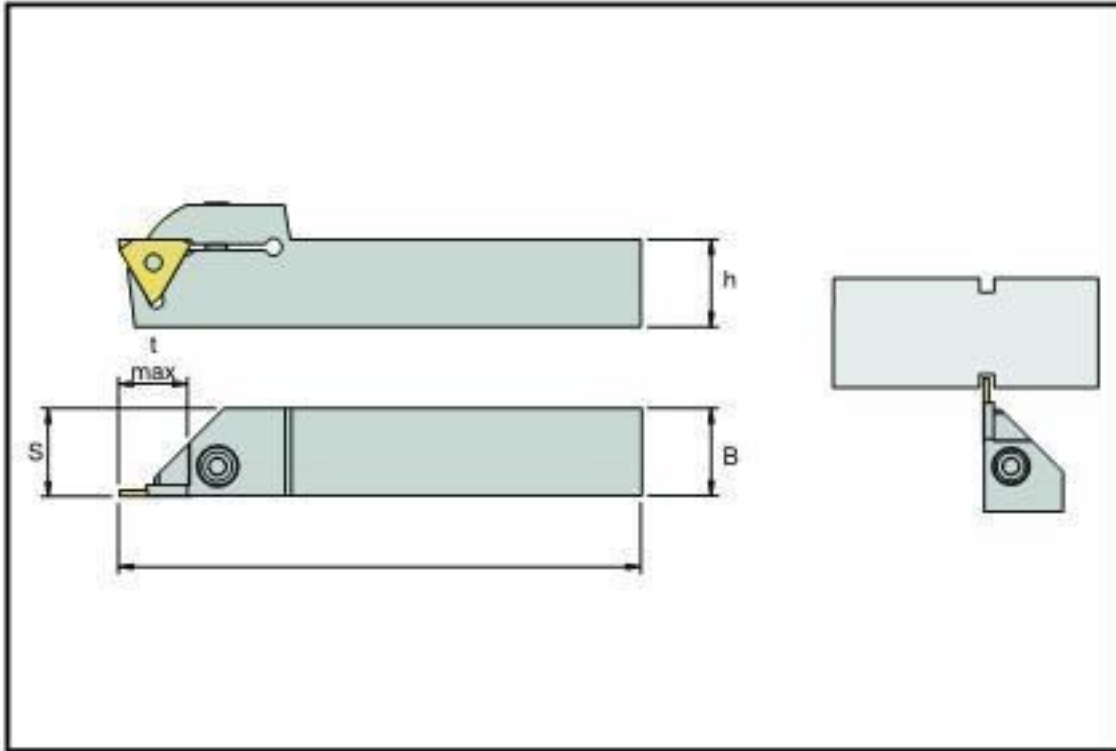



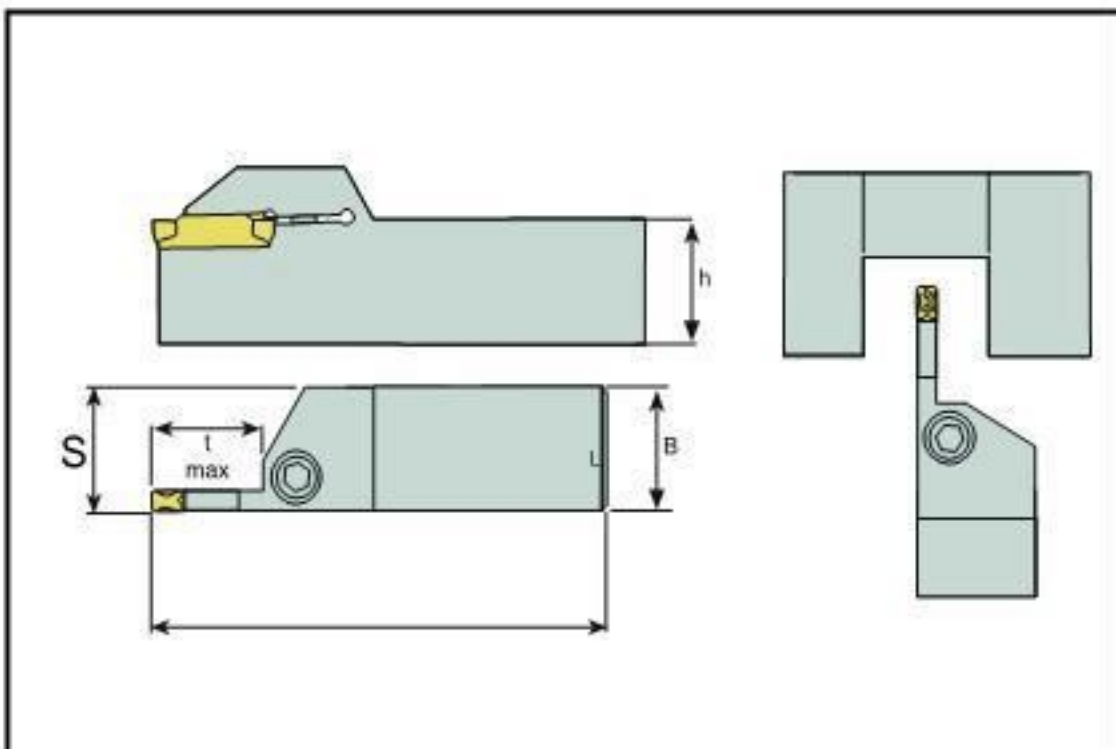

KOD CODE	ÖLÇÜLER DIMENSION (mm)					KESİCİ UÇ INSERT	YEDEK PARÇALAR SPARE PARTS		
	h	B	L	S	t t _{max}		Sıkma Vidası Clamp Screw	Pul Stamp	Anahtar Allen Key
BDKT R/L HORN S312									
1616 BDKT R/L -H-S312	16	16	100	16,2	6	HORN S312-05-2C			
2020 BDKT R/L -H-S312	20	20	125	20,2	6				
2525 BDKT R/L -H-S312	25	25	150	25,2	6				
							BKTV M6x25	-	AA5

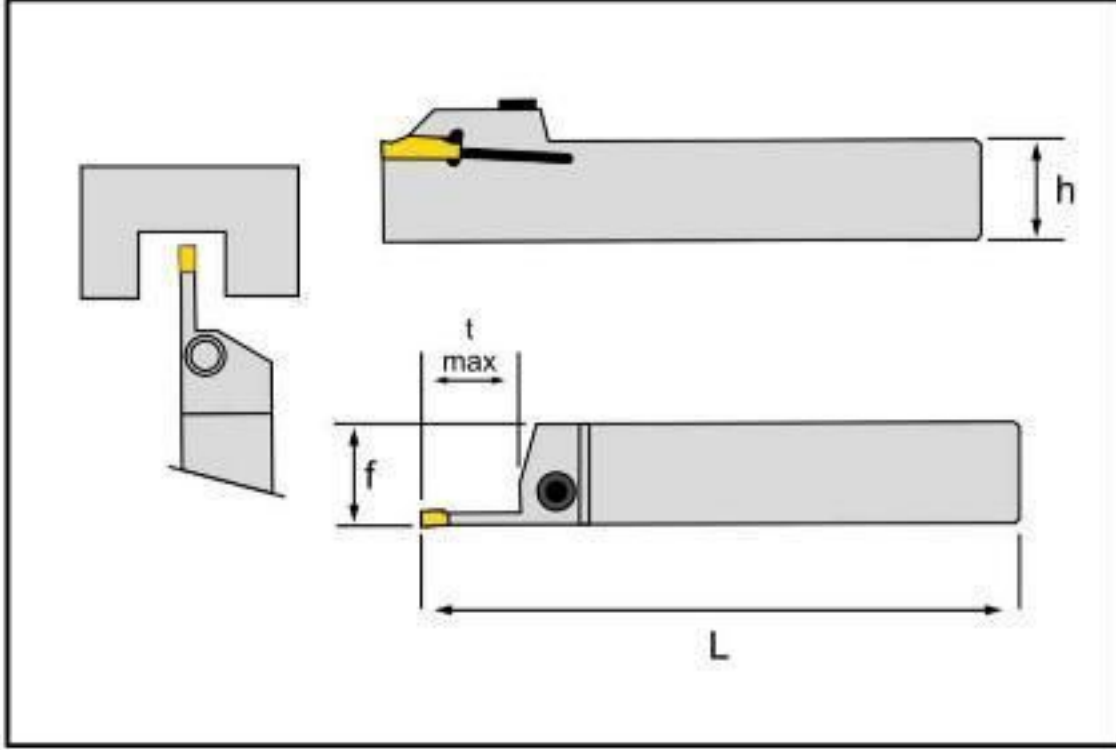

KOD CODE	ÖLÇÜLER DIMENSION (mm)					KESİCİ UÇ INSERT	YEDEK PARÇALAR SPARE PARTS		
	h	B	L	S	t t _{max}		Sıkma Vidası Clamp Screw	Pul Stamp	Anahtar Allen Key
BDKT R/L TGT									
1212 BDKT R/L -T-2C	12	12	100	12,3	15	TGTC-2C			
1616 BDKT R/L -T-2C	16	16	100	16,3	15				
2020 BDKT R/L -T-2C	20	20	125	20,3	17				
2525 BDKT R/L -T-2C	25	25	150	25,3	17				
1212 BDKT R/L -T-3C	12	12	100	12,3	15	TGTC-3C			
1616 BDKT R/L -T-3C	16	16	100	16,4	15				
2020 BDKT R/L -T-3C	20	20	125	20,4	22				
2525 BDKT R/L -T-3C	25	25	150	25,4	22				
							BKDT M5x12	-	AA4
							BKDT M6x25	-	AA5
							BKDT M5x12	-	AA4
							BKDT M6x25	-	AA5

DIŞ ÇAP KANAL AÇMA TAKIMLARI External Grooving Toolholders



KOD CODE	ÖLÇÜLER DIMENSION (mm)					KESİCİ UÇ INSERT	YEDEK PARÇALAR SPARE PARTS		
	H	B	L	S	t max		Sıkma Vidası Clamp Screw	Pul Stamp	Anahtar Allen Key
BDKT R/L ZCC2									
2020 BDKT R/L -ZCC2-2C	20	20	125	20,3	20	ZTBD 2002	BKTV M6x25	-	AA5
2525 BDKT R/L -ZCC2-2C	25	25	150	25,3	22				
2020 BDKT R/L -ZCC2-3C	20	20	125	20,3	20				
2525 BDKT R/L -ZCC2-3C	25	25	150	25,3	22				
2020 BDKT R/L -ZCC2-4C	20	20	125	20,5	20				
2525 BDKT R/L -ZCC2-4C	25	25	150	25,5	22				
2020 BDKT R/L -ZCC2-5C	20	20	125	20,5	20	ZTFD 0303			
2525 BDKT R/L -ZCC2-5C	25	25	150	25,5	25	ZTGD 0404			
						ZTHD 0504			



DIŞ ÇAP ALIN KANAL AÇMA TAKIMLARI Face External Grooving Toolholders

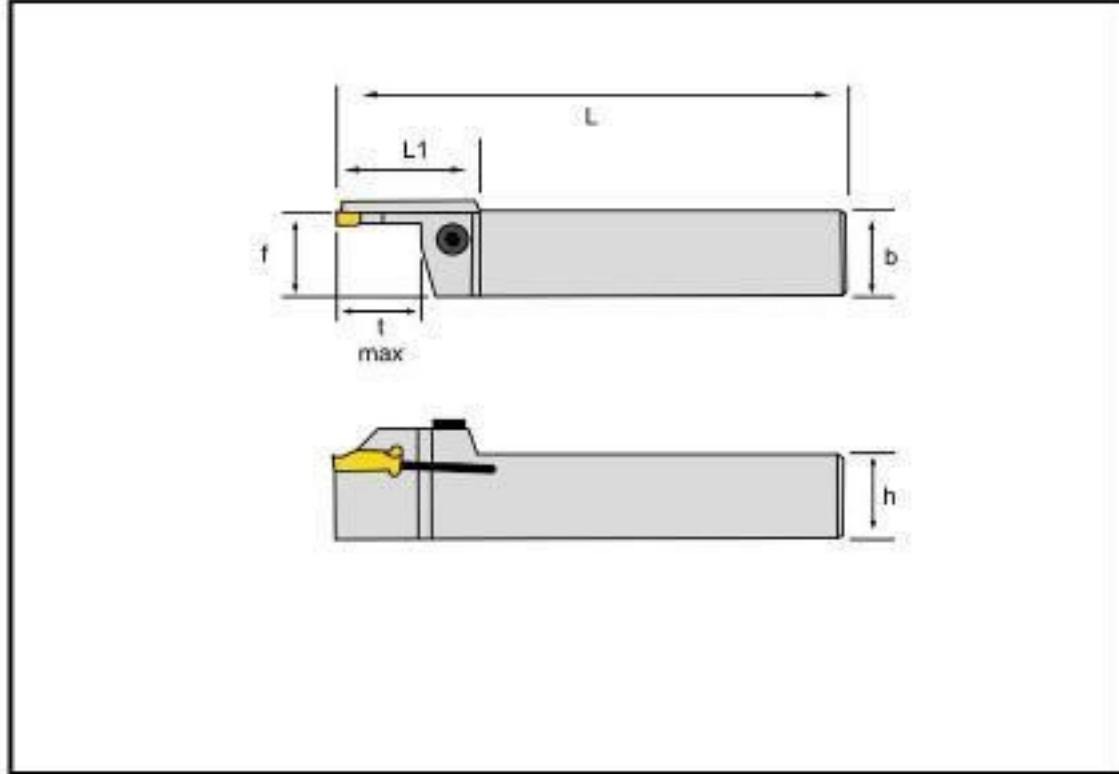

KOD CODE	ÖLÇÜLER DIMENSION (mm)							KESİCİ UÇ INSERT	YEDEK PARÇALAR SPARE PARTS		
	h	B	L	S	t max	ØD mix	ØD max		Sıkma Vidası Clamp Screw	Pul Stamp	Anahtar Allen Key
KORLOY ALIN BOŞALTMA TAKIMLARI											
2525 BDKT-A-K (Ø24X36)	25	25	150	26,5	17	24	36	KORLOY 3C	BDKT M6x25	-	AA5
2525 BDKT-A-K (Ø36x48)	25	25	150	26,5	17	36	48				
2525 BDKT-A-K (Ø48x70)	25	25	150	26,5	17	48	70				
2525 BDKT-A-K (Ø70x110)	25	25	150	26,5	17	70	110				
2525 BDKT-A-K (Ø100x150)	25	25	150	26,5	17	100	150				
2525 BDKT-A-K (Ø150x200)	25	25	150	26,5	17	150	200				
2525 BDKT-A-K (Ø24X36)	25	25	150	26,5	22	24	36	KORLOY 4C	BDKT M6x25	-	AA5
2525 BDKT-A-K (Ø36x48)	25	25	150	26,5	22	36	48				
2525 BDKT-A-K (Ø48x70)	25	25	150	26,5	22	48	70				
2525 BDKT-A-K (Ø70x110)	25	25	150	26,5	22	70	110				
2525 BDKT-A-K (Ø100x150)	25	25	150	26,5	22	100	150				
2525 BDKT-A-K (Ø150x200)	25	25	150	26,5	22	150	200				

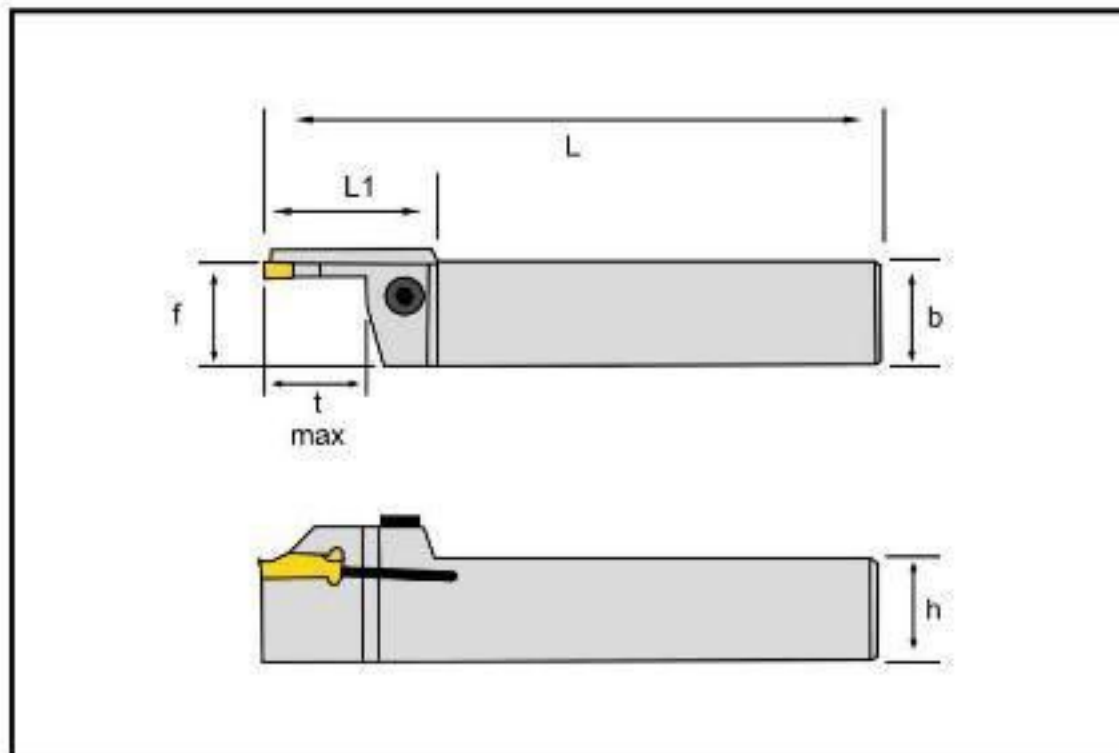





KOD CODE	ÖLÇÜLER DIMENSION (mm)							KESİCİ UÇ INSERT	YEDEK PARÇALAR SPARE PARTS		
	h	B	L	S	t max	ØD mix	ØD max		Sıkma Vidası Clamp Screw	Pul Stamp	Anahtar Allen Key
ISCAR ALIN BOŞALTMA TAKIMLARI											
2525 BDKT-A-I (Ø24X36)	25	25	150	26,5	22	24	36	ISCAR 4C	BDKT M6x25	-	AA5
2525 BDKT-A-I (Ø36x48)	25	25	150	26,5	22	36	48				
2525 BDKT-A-I (Ø48x70)	25	25	150	26,5	22	48	70				
2525 BDKT-A-I (Ø70x110)	25	25	150	26,5	22	70	110				
2525 BDKT-A-I (Ø100x150)	25	25	150	26,5	22	100	150				
2525 BDKT-A-I (Ø150x200)	25	25	150	26,5	22	150	200				

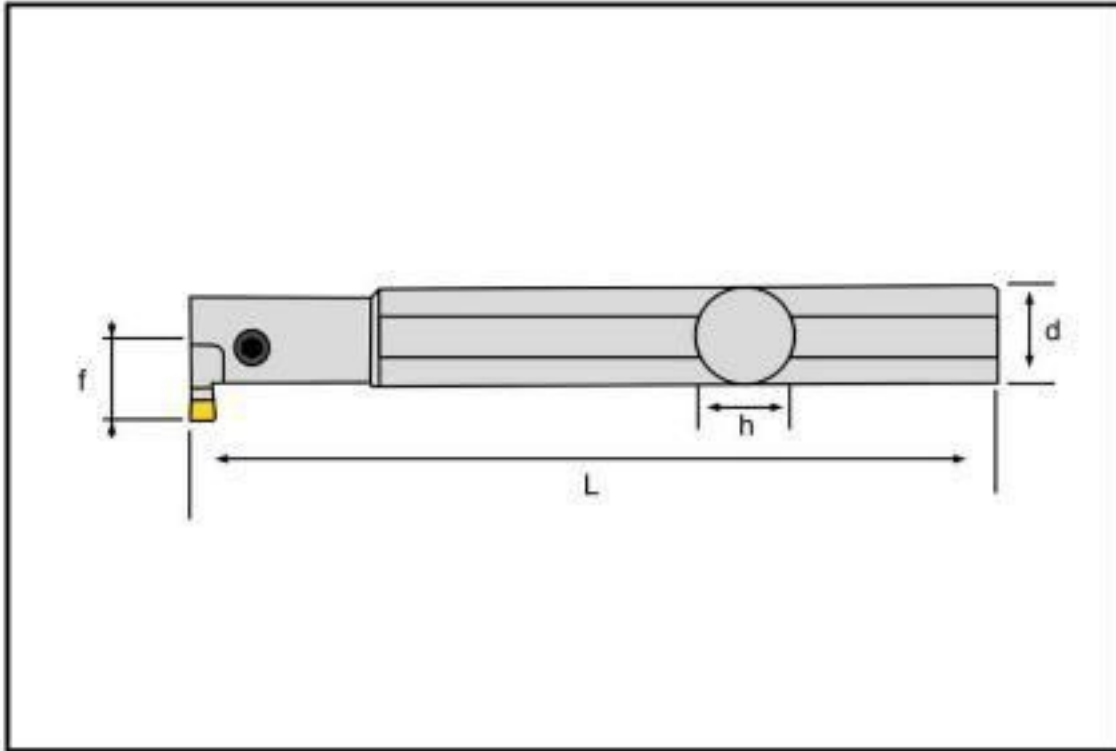

DELİK İÇİ KANAL AÇMA TAKIMLARI
INTERNAL GROOVING TOOLHOLDERS

DELİK İÇİ KANAL AÇMA TAKIMLARI Internal Grooving Toolholders



KOD CODE	ÖLÇÜLER DIMENSION (mm)							KESİCİ UÇ INSERT	YEDEK PARÇALAR SPARE PARTS		
	d	D	L	I	t _{max}	H	S		Sıkma Vidası Clamp Screw	Pul Stamp	Anahtar Allen Key
BIKT R/L KORLOY											
BIKT R/L 16-K2C	16	20	150	33	4	15	11,5	KORLOY 2C	BKTV M4x12	-	AA4
BIKT R/L 20-K2C	20	26	170	33	4	18	14,5		BKTV M6x25	-	AA5
BIKT R/L 25-K2C	25	32	200	45	4	23	18,5	KORLOY 3C	BKTV M6x25	-	AA5
BIKT R/L 20-K3C	20	26	170	33	6	18	15				
BIKT R/L 25-K3C	25	32	200	45	6	23	18,5	KORLOY 4C	BKTV M6x25	-	AA5
BIKT R/L 32-K3C	32	40	250	49	8	30	22				
BIKT R/L 40-K3C	40	48	300	54	8	37	27	KORLOY 5C	BKTV M6x25	-	AA5
BIKT R/L 20-K4C	20	26	170	33	6	18	14				
BIKT R/L 25-K4C	25	32	200	45	6	23	18,5				
BIKT R/L 32-K4C	32	40	250	49	6	30	22				
BIKT R/L 40-K4C	40	48	300	54	6	37	27				
BIKT R/L 25-K5C	25	32	200	45	7	23	18,5				
BIKT R/L 32-K5C	32	40	250	49	7	30	22				
BIKT R/L 40-K5C	40	48	300	54	7	37	27				



DELİK İÇİ KANAL AÇMA TAKIMLARI Internal Grooving Toolholders

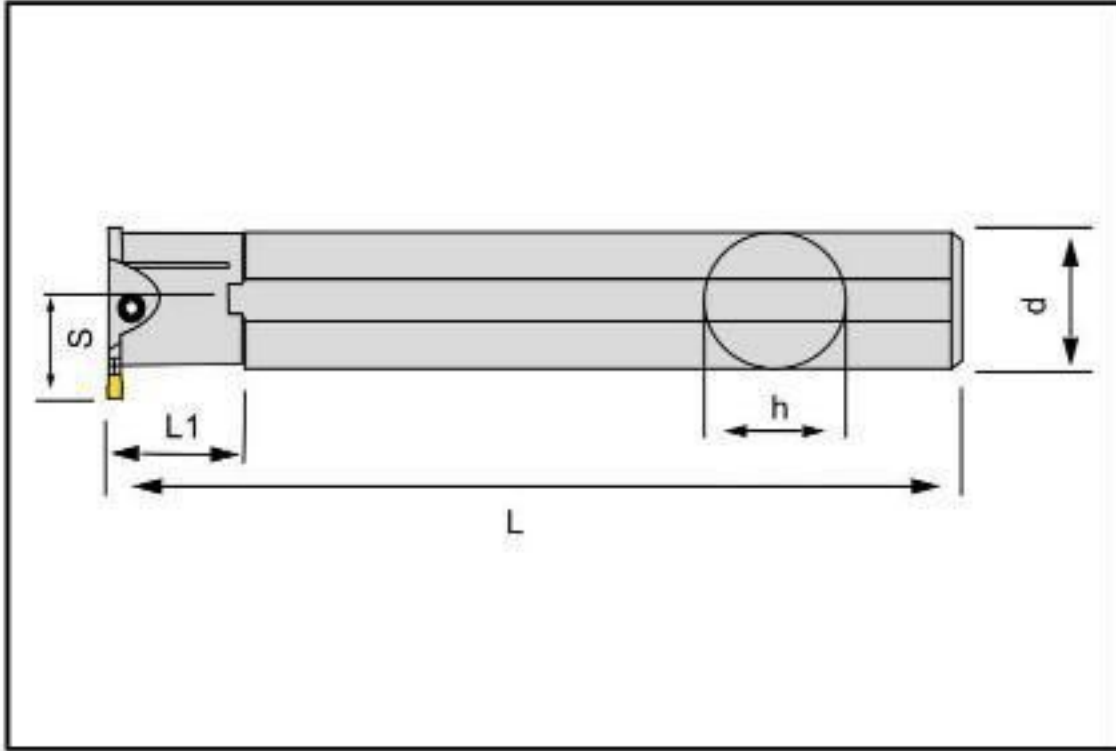

KOD CODE	ÖLÇÜLER DIMENSION (mm)								KESİCİ UÇ INSERT	YEDEK PARÇALAR SPARE PARTS		
	d	D	L	I	t _{max}	H	S	Sıkma Vidası Clamp Screw		Pul Stamp	Anahtar Allen Key	
BIKT R/L HORN-229												
BIKT R/L 25-H3C (S229)	25	32	200	43	7	23	18,9	HRN S229 3C				
BIKT R/L 32-H3C (S229)	32	40	250	65	7	30	21,5					
BIKT R/L 40-H3C (S229)	40	48	300	50	7	37	26,5					
BIKT R/L 25-H4C (S229)	25	31	200	40	7	23	18,9	HRN S229 4C				
BIKT R/L 32-H4C (S229)	32	37	250	65	7	30	21,5					
BIKT R/L 40-H4C (S229)	40	40	300	50	7	37	26,5					
BIKT R/L 25-H5C (S229)	25	32	200	45	7	23	18,9	HRN S229 5C				
BIKT R/L 32-H5C (S229)	32	40	250	50	7	30	21,5					
BIKT R/L 40-H5C (S229)	40	50	300	70	7	37	26,5					

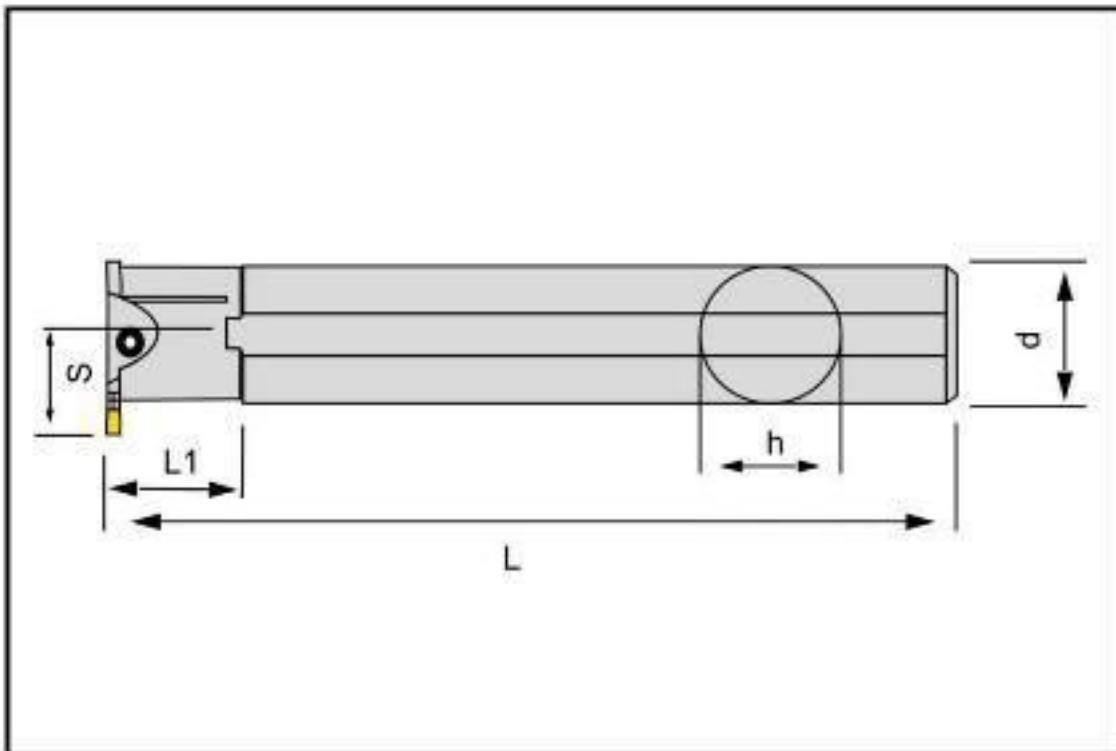

KOD CODE	ÖLÇÜLER DIMENSION (mm)								KESİCİ UÇ INSERT	YEDEK PARÇALAR SPARE PARTS		
	d	D	L	I	t _{max}	H	S	Sıkma Vidası Clamp Screw		Pul Stamp	Anahtar Allen Key	
BIKT R/L HORN-224												
BIKT R/L 20-HK2C (S224)	20	26	170	32	6	18	15	HRN S224 3C				
BIKT R/L 25-HK2C (S224)	25	32	200	42	6	23	18,9					
BIKT R/L 20-HK3C (S224)	20	26	170	33	6	18	15					
BIKT R/L 25-HK3C (S224)	25	32	200	43	6	23	18,9	HRN S224 4C				
BIKT R/L 32-HK3C (S224)	32	40	250	50	6	30	21,5					
BIKT R/L 20-HK4C (S224)	20	26	170	34	6	18	15					
BIKT R/L 25-HK4C (S224)	25	32	200	40	6	23	18,9	HRN S224 5C				
BIKT R/L 32-HK4C (S224)	32	40	250	50	6	30	21,5					

DELİK İÇİ KANAL AÇMA TAKIMLARI Internal Grooving Toolholders

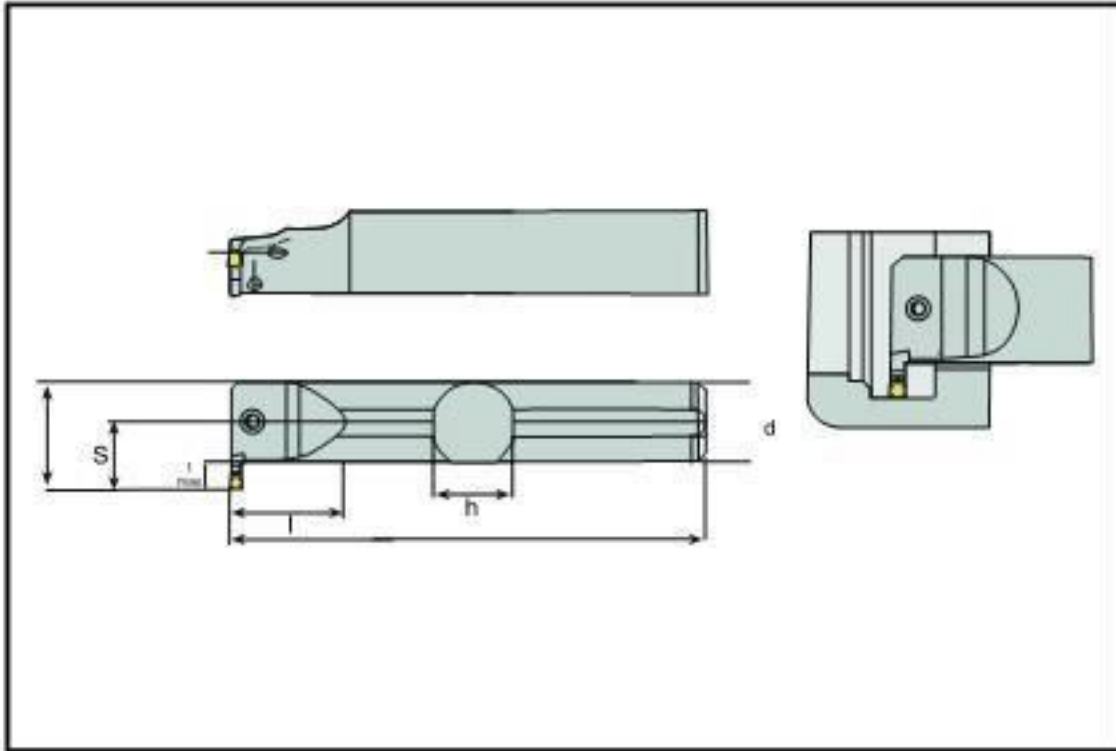

KOD CODE	ÖLÇÜLER DIMENSION (mm)							KEŞİCİ UÇ INSERT	YEDEK PARÇALAR SPARE PARTS		
	d	D	L	I	t _{max}	H	S		Sıkma Vidası Clamp Screw	Pul Stamp	Anahtar Allen Key
BIKT R/L ZCC-2											
BIKT R/L 20-ZCC2-3C (123)	20	26	170	32	5	18	15	ZTBD 2002	BKT M6x25	-	AA5
BIKT R/L 25-ZCC2-3C (123)	25	32	200	42	5	23	18				
BIKT R/L 32-ZCC2-3C (123)	32	40	250	42	6	30	22	ZTFD 0303	BKT M6x25	-	AA5
BIKT R/L 25-ZCC2-4C (123)	25	32	200	42	6	23	18				
BIKT R/L 32-ZCC2-4C (123)	32	40	250	42	7	30	22	ZTCD 0404	BKT M6x25	-	AA5
BIKT R/L 32-ZCC2-5C (123)	32	40	250	42	8	30	22				
BIKT R/L 40-ZCC2-5C (123)	40	48	300	53	8	37	27				





DIŞ VE İÇ ÇAP DIŞ AÇMA TAKIMLARI

EXTERNAL AND DIAMETER SCREWING TOOLS

DIŞ ve İÇ ÇAP DIŞ AÇMA TAKIMLARI External and Internal Threading Toolholders

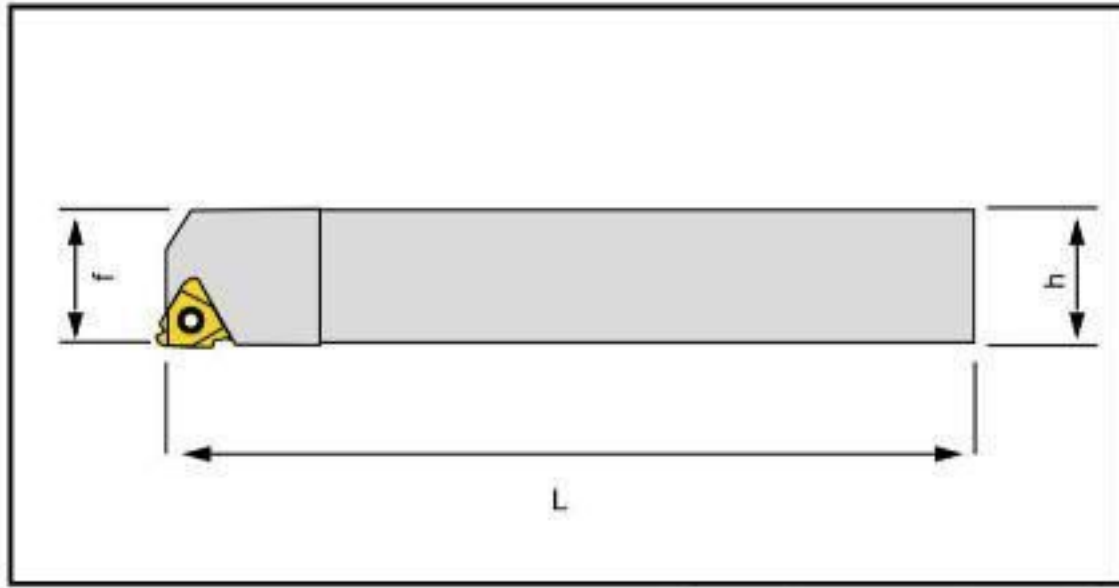

KOD CODE	ÖLÇÜLER DIMENSION (mm)				KESİCİ UÇ INSERT	YEDEK PARÇALAR SPARE PARTS			
	H	B	L	F		Sıkma Vidası Clamp Screw	Altık Shim	Altık Vidası Shim Screw	Anahtar Torx Key
SER/L DIŞ TAKIMLARI									
SER/L 0808 E11	08	08	70	11	11 ER/EL	SSV M2,5X7,5	-	-	T08
SER/L 1010 E11	10	10	70	11					
SER/L 1616 H11	16	16	100	16					
SER/L 1616 H16	16	16	100	16	16 ER/EL	SSV M3,5X14	BAX- ER/L-16	SBVA M5.05 A3,5x11	T15
SER/L 2020 K16	20	20	125	20					
SER/L 2525 M16	25	25	150	25					
SER/L 3232 P16	32	32	170	32	22 ER/EL	SSV M4X16	-	-	T15
SER/L 2525 M22	25	25	150	25					
SER/L 3232 P22	32	32	170	32					
SER/L 4040 S22	40	40	250	40					

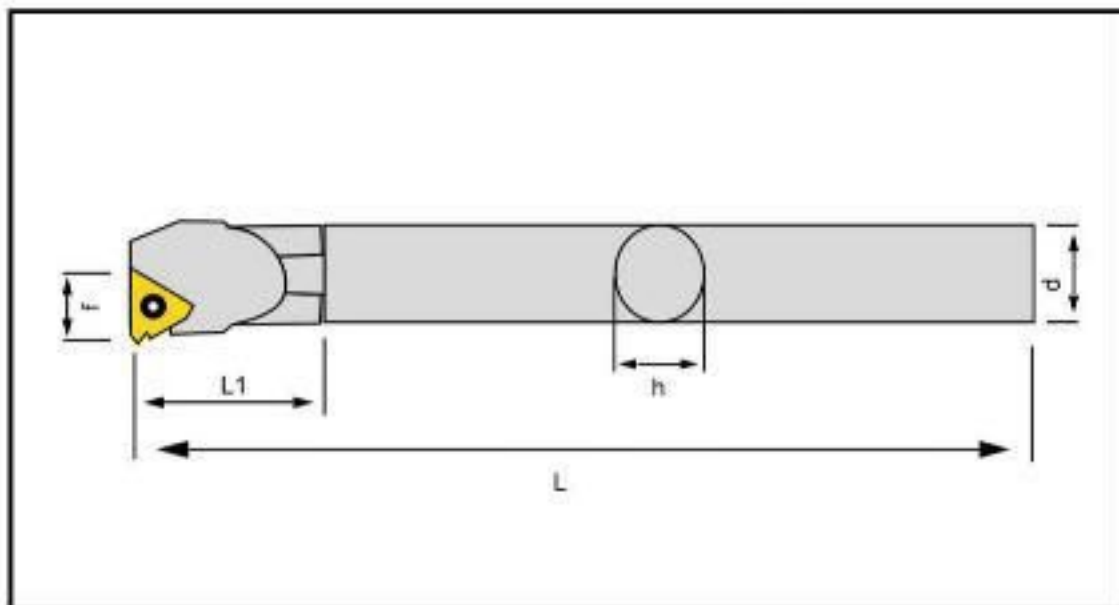

KOD CODE	ÖLÇÜLER DIMENSION (mm)						KESİCİ UÇ INSERT	YEDEK PARÇALAR SPARE PARTS			
	d1	D	L	L1	F	D min		Sıkma Vidası Clamp Screw	Altık Shim	Altık Vidası Shim Screw	Anahtar Allen Key
SIR/L İÇ DIŞ KATERİ											
SIR/L S16X07 M08	16	7	150	18	5,3	7,8	08 IR/L	SSV M2,2X5	-	-	T07
SIR/L S10 H11	10	10	100	-	7,4	12	11 IR/L	SSV M2,5X7,5	-	-	T08
SIR/L S12 K11	12	12	125	-	8,4	16					
SIR/L S16X10 M11	16	10	150	25	7,4	12					
SIR/L S16x13 M11	16	13	150	32	8,9	15	16 IR/L	SSV M3,5X11	-	-	T15
SIR/L S16x13 M16	16	16	150	32	10,2	16					
SIR/L S16 M16	16	13	150	-	11,7	19					
SIR/L S20x16 P16	20	16	170	40	11,7	19	16 IR/L	SSV M3,5X14	BAX- IR/L 16	SBVA M5.05 A3,5	T15
SIR/L S20 P16	20	20	170	-	13,7	24					
SIR/L S25 R16	25	25	200	-	16,2	29					
SIR/L S32 S16	32	32	250	-	19,7	36	22 IR/L	SSV M4X9	-	-	T22
SIR/L S40 T16	40	40	300	-	23,7	44					
SIR/L S20 P22	20	20	170	-	14	24					
SIR/L S25 R22	25	25	200	-	18,1	29					
SIR/L S32 S22	32	32	250	-	21,6	38					
SIR/L S40 T22	40	40	300	-	25,6	46					



S SISTEM FREZELER

S SYSTEM END MILLS

ST90 AP10 D22 L200 Z3

P115
150615

BLAX CUTTING TOOLS

BLAX CUTTING TOOLS

BLAX CUTTING TOOLS



TF90 CC06 D25x10 Z4 L120

TCM16

S SİSTEM FREZELER

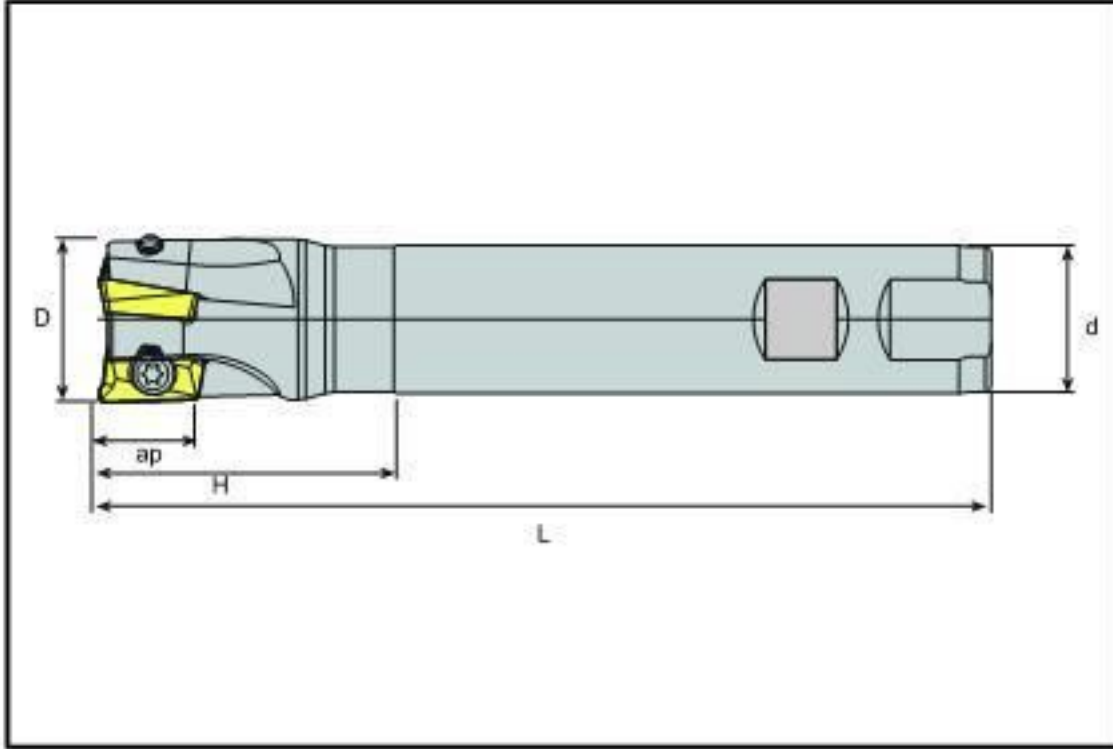
S System end mills



KOD CODE	ÖLÇÜLER DIMENSION (mm)						KESİCİ UÇ INSERT	YEDEK PARÇALAR SPARE PARTS	
	D	d	Z	L	H	ap		Sıkma Vidası Clamp Screw	Anahtar Torx Key
APKT-10 -BST90°									
BST90-AP10-D12-W16-L100-Z01	12	16	01	100	30	10	AP..1003	SSV M2,5X7,5	T08
BST90-AP10-D14-W16-L100-Z01	14	16	01	100	30	10			
BST90-AP10-D16-W16-L100-Z02	16	16	02	100	30	10			
BST90-AP10-D18-W16-L100-Z02	18	16	02	100	40	10			
BST90-AP10-D20-W20-L100-Z03	20	20	03	100	30	10			
BST90-AP10-D22-W20-L100-Z03	22	20	03	100	30	10			
BST90-AP10-D24-W25-L100-Z03	24	25	03	100	30	10			
BST90-AP10-D25-W25-L100-Z03	25	25	03	100	30	10			
BST90-AP10-D30-W25-L100-Z04	30	25	03	100	50	10			
BST90-AP10-D32-W32-L100-Z04	32	32	04	100	50	10			
BST90-AP10-D35-W32-L100-Z04	35	32	04	100	50	10			
BST90-AP10-D40-W32-L100-Z05	40	32	05	100	50	10			
BST90-AP10-D12-W16-L120-Z01	12	16	01	120	30	10			
BST90-AP10-D14-W16-L120-Z01	14	16	01	120	30	10			
BST90-AP10-D16-W16-L120-Z02	16	16	02	120	30	10			
BST90-AP10-D16-W16-L120-Z02-H	16	16	02	120	30	10			
BST90-AP10-D18-W16-L120-Z02	18	16	02	120	30	10			
BST90-AP10-D20-W20-L120-Z03	20	20	03	120	30	10			
BST90-AP10-D20-W20-L120-Z03-H	20	20	03	120	30	10			
BST90-AP10-D22-W20-L120-Z03	22	20	03	120	30	10			
BST90-AP10-D24-W20-L120-Z03	24	20	03	120	30	10			
BST90-AP10-D25-W25-L120-Z03	25	25	03	120	50	10			
BST90-AP10-D25-W25-L120-Z03-H	25	25	03	120	50	10			
BST90-AP10-D30-W25-L120-Z04	30	25	03	120	50	10			
BST90-AP10-D32-W32-L120-Z04	32	32	04	120	50	10			
BST90-AP10-D32-W32-L120-Z04-H	32	32	04	120	50	10			
BST90-AP10-D35-W32-L120-Z04	35	32	04	120	50	10			
BST90-AP10-D40-W32-L120-Z05	40	32	05	120	50	10			
BST90-AP10-D16-W16-L150-Z02	16	16	02	150	50	10			
BST90-AP10-D18-W16-L150-Z02	18	16	02	150	40	10			
BST90-AP10-D20-W20-L150-Z03	20	20	03	150	50	10			
BST90-AP10-D22-W20-L150-Z03	22	20	03	150	50	10			
BST90-AP10-D25-W25-L150-Z03	25	25	03	150	50	10			
BST90-AP10-D32-W25-L150-Z04	32	25	04	150	50	10			
BST90-AP10-D32-W32-L150-Z04	32	32	04	150	50	10			
BST90-AP10-D40-W32-L150-Z05	40	32	05	150	50	10			
BST90-AP10-D16-C16-L200-Z02	16	16	02	200	100	10			
BST90-AP10-D18-C16-L200-Z02	18	16	02	200	100	10			
BST90-AP10-D20-C20-L200-Z03	20	20	03	200	100	10			
BST90-AP10-D22-C20-L200-Z03	22	20	03	200	100	10			
BST90-AP10-D25-C25-L200-Z03	25	25	03	200	100	10			
BST90-AP10-D25-C25-L250-Z03	25	25	03	250	100	10			

S SİSTEM FREZELER

S System end mills

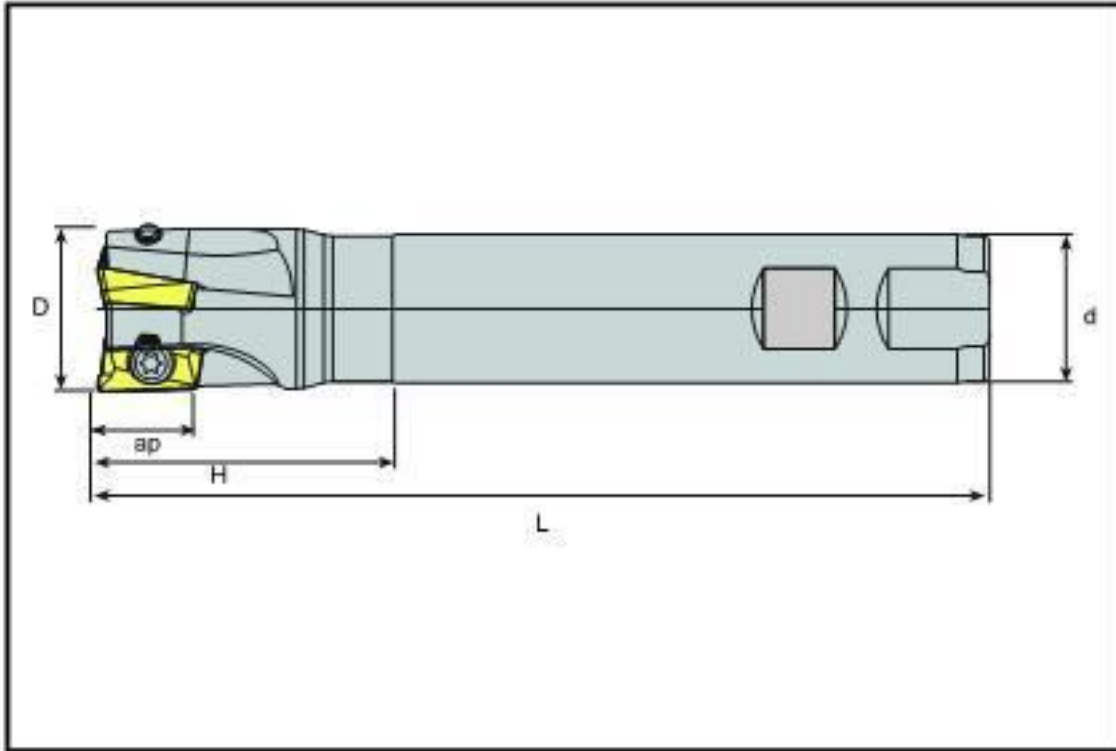

KOD CODE	ÖLÇÜLER DIMENSION (mm)						KESİCİ UÇ INSERT	YEDEK PARÇALAR SPARE PARTS	
	D	d	Z	L	H	ap		Sıkma Vidası Clamp Screw	Anahtar Torx Key
APKT-11-12 BST90°									
BST90-AP11-D16-W16-L120-Z02	16	16	02	120	50	11	AP..11T3..	SSV M2,5X7,5	T08
BST90-AP11-D20-W20-L120-Z03	20	20	03	120	50	11			
BST90-AP11-D25-W25-L120-Z03	25	25	03	120	50	11			
BST90-AP11-D26-W26-L120-Z03	26	25	03	120	50	11			
BST90-AP11-D32-W32-L120-Z04	32	32	04	120	50	11			
BST90-AP11-D16-W16-L150-Z02	16	16	02	150	50	11			
BST90-AP11-D20-W20-L150-Z03	20	20	03	150	50	11			
BST90-AP11-D25-W25-L150-Z03	25	25	03	150	50	11			
BST90-AP11-D26-W25-L150-Z03	26	25	03	150	50	11			
BST90-AP11-D32-W32-L150-Z04	32	32	04	150	50	11			
BST90-AP11-D16-C16-L200-Z02	16	16	02	200	100	11			
BST90-AP11-D20-C20-L200-Z03	20	20	03	200	100	11			
BST90-AP11-D25-C25-L200-Z03	25	25	03	200	100	11			
BST90-AP11-D26-C26-L200-Z03	26	25	03	200	100	11			
BST90-AP11-D32-C32-L200-Z04	32	32	04	200	100	11			
BST90-AP12-D20-W20-L150-Z02	20	20	02	150	30	12	AP..1204	SSV M3X9	T08
BST90-AP12-D21-W20-L150-Z02	21	20	02	150	30	12			
BST90-AP12-D25-W25-L150-Z03	25	25	02	150	40	12			
BST90-AP12-D32-W32-L150-Z03	32	32	03	150	35	12			
BST90-AP12-D21-C20-L200-Z02	21	20	02	200	30	12			
BST90-AP12-D26-C25-L200-Z03	26	25	03	200	35	12			

S SİSTEM FREZELER

S System end mills

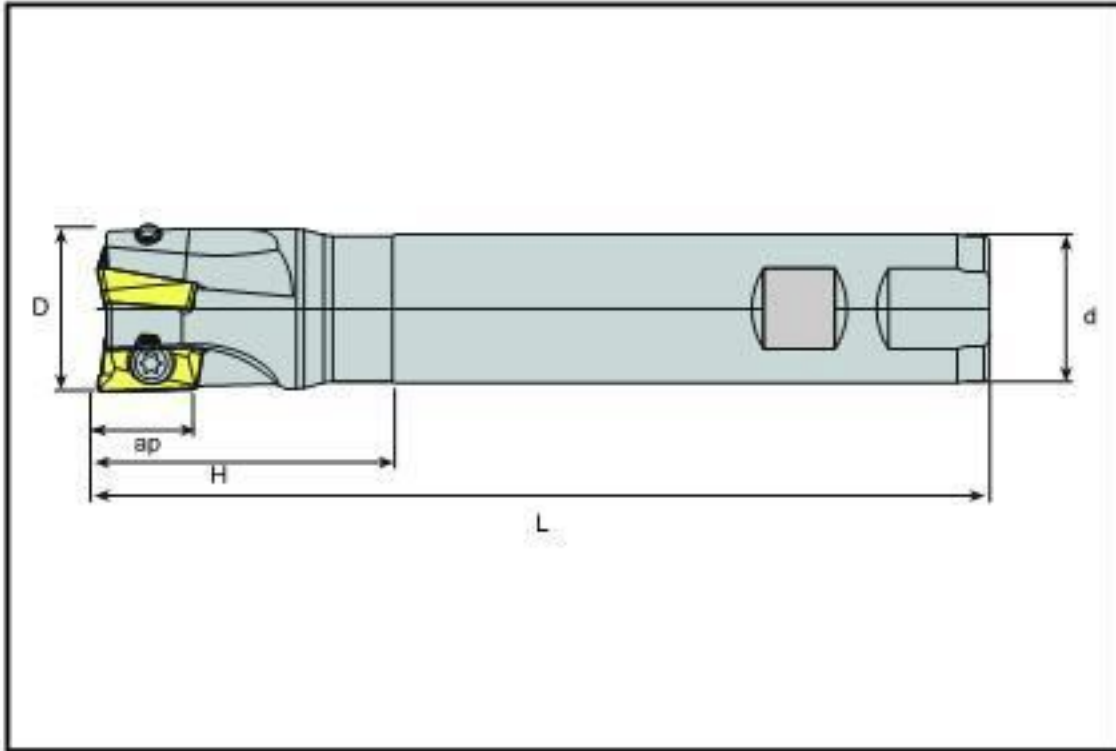

KOD CODE	ÖLÇÜLER DIMENSION (mm)						KESİCİ UÇ INSERT	YEDEK PARÇALAR SPARE PARTS	
	D	d	Z	L	H	ap		Sıkma Vidası Clamp Screw	Anahtar Torx Key
APKT-16-17 BST90°									
BST90-AP16-D25-W25-L120-Z02	25	25	02	120	35	16	AP..1604..	SSV M3,5X99	T15
BST90-AP16-D26-W25-L120-Z02	26	25	02	120	40	16			
BST90-AP16-D28-W25-L120-Z03	28	25	02	120	50	16			
BST90-AP16-D30-W25-L120-Z03	30	25	03	120	40	16			
BST90-AP16-D32-W32-L120-Z03	32	32	03	120	40	16			
BST90-AP16-D34-W32-L120-Z03	34	32	03	120	40	16			
BST90-AP16-D35-W32-L120-Z03	35	32	03	120	40	16			
BST90-AP16-D36-W36-L120-Z03	36	32	03	120	40	16			
BST90-AP16-D38-W32-L120-Z03	38	32	03	120	50	16			
BST90-AP16-D40-W32-L120-Z04	40	32	04	120	50	16			
BST90-AP16-D25-W25-L150-Z02	25	25	02	150	50	16			
BST90-AP16-D30-W25-L150-Z03	30	25	03	150	50	16			
BST90-AP16-D32-W32-L150-Z03	32	32	03	150	50	16			
BST90-AP16-D35-W32-L150-Z03	35	32	03	150	50	16			
BST90-AP16-D40-W32-L150-Z04	40	32	04	150	50	16			
BST90-AP16-D25-C25-L200-Z02	25	25	02	200	100	16			
BST90-AP16-D30-C25-L200-Z03	30	25	03	200	100	16			
BST90-AP16-D32-C32-L200-Z03	32	32	03	200	100	16			
BST90-AP16-D35-C32-L200-Z03	35	32	03	200	50	16			
BST90-AP16-D40-C32-L200-Z04	40	32	04	200	50	16			
BST90-AP17-D25-W25-L120-Z02	25	25	02	120	40	17	AP..1705..	SSV M3,5X9	T15
BST90-AP17-D32-W32-L150-Z03	32	32	03	150	45	17			
BST90-AP17-D26-C25-L200-Z02	26	25	02	200	40	17			
BST90-AP17-D26-C25-L250-Z02	26	25	02	250	40	17			
BST90-AP17-D30-C25-L300-Z02	30	25	02	300	40	17			

S SİSTEM FREZELER

S System end mills

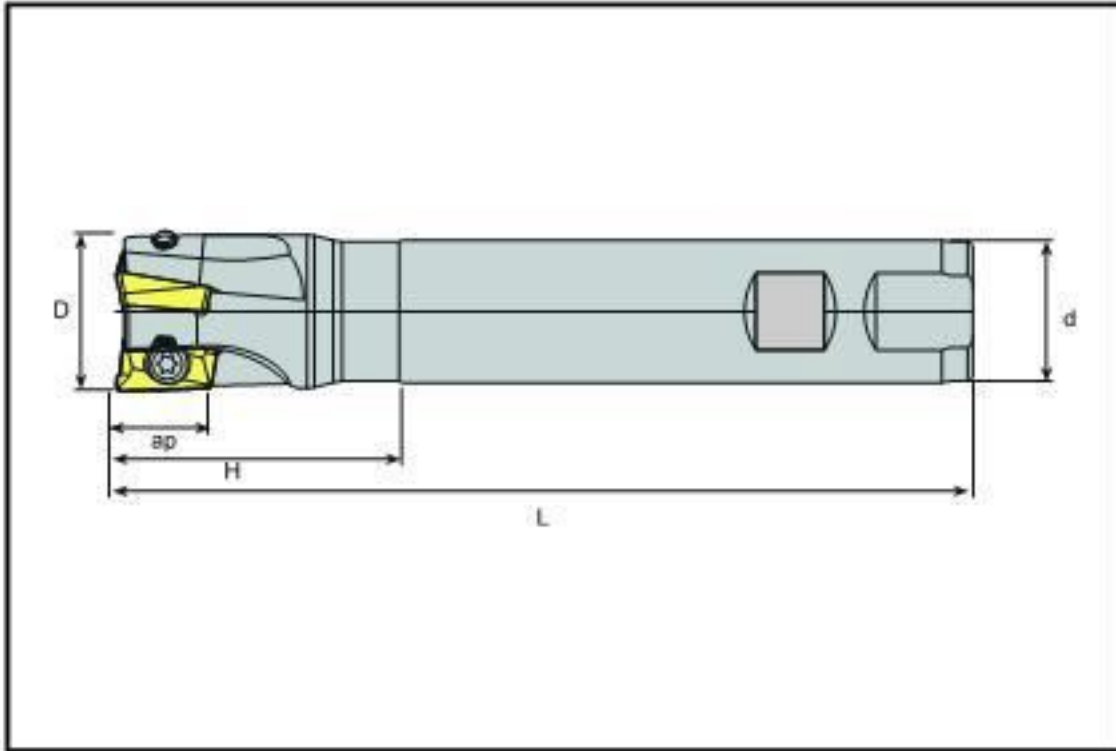

KOD CODE	ÖLÇÜLER DIMENSION (mm)						KESİCİ UÇ INSERT	YEDEK PARÇALAR SPARE PARTS	
	D	d	Z	L	H	ap		Sıkma Vidası Clamp Screw	Anahtar Torx Key
R390.11-R390.17 BST90°									
BST90-R390.11-D16-W16-L100-Z02-H	16	16	2	100	30	11	R390.11T3..	SSV M2,5X6	T08
BST90-R390.11-D20-W20-L100-Z03-H	20	20	3	100	30	11			
BST90-R390.11-D25-W25-L100-Z03-H	25	25	3	100	35	11			
BST90-R390.11-D16-W16-L150-Z03	16	16	2	150	50	11			
BST90-R390.11-D16-W16-L150-Z03-H	16	16	2	150	50	11			
BST90-R390.11-D20-W20-L150-Z03	20	20	3	150	50	11			
BST90-R390.11-D20-W20-L150-Z03-H	20	20	3	150	50	11			
BST90-R390.11-D25-W25-L150-Z03	25	25	3	150	50	11			
BST90-R390.11-D25-W25-L150-Z03-H	25	25	3	150	50	11	R390.1704..	SSV M3,5x11	T15
BST90-R390.17-D25-W25-L150-Z02	25	25	2	150	50	17			
BST90-R390.17-D25-W25-L150-Z02-H	25	25	2	150	50	17			
BST90-R390.17-D30-W25-L150-Z02	30	25	3	150	50	17			
BST90-R390.17-D30-W25-L150-Z02-H	30	25	3	150	50	17			



S SİSTEM FREZELER

S System end mills

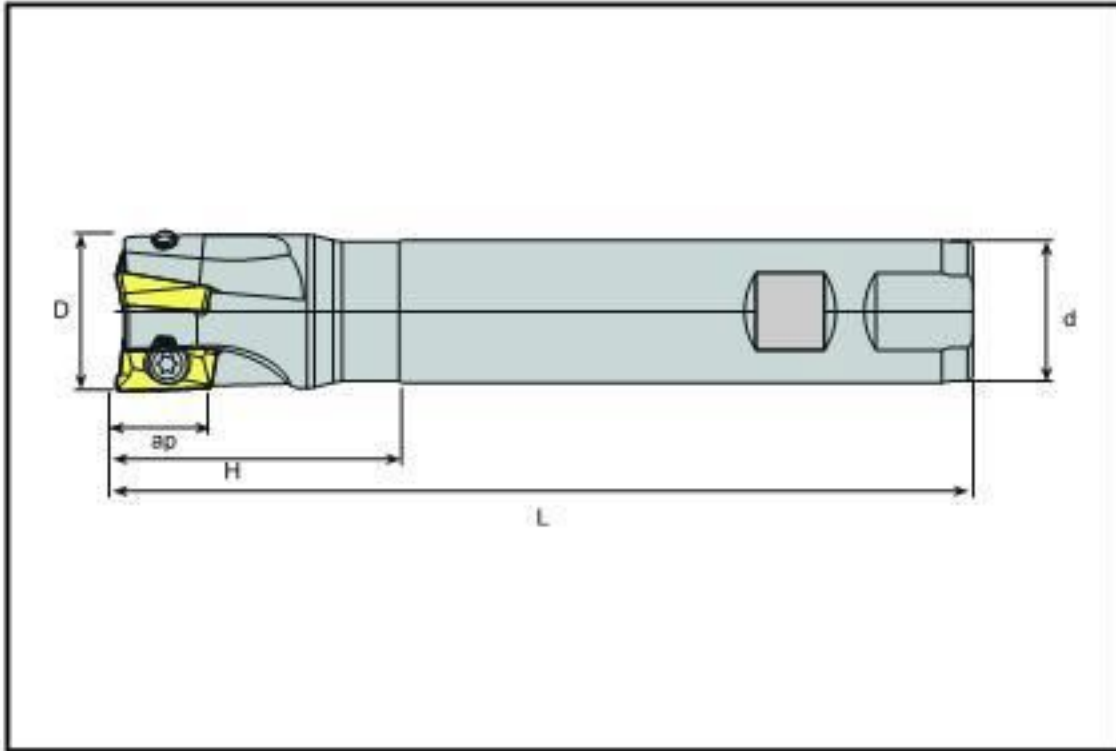

KOD CODE	ÖLÇÜLER DIMENSION (mm)						KESİCİ UÇ INSERT	YEDEK PARÇALAR SPARE PARTS	
	D	d	Z	L	H	ap		Sıkma Vidası Clamp Screw	Anahtar Torx Key
AX.T12- 17 BST90°									
BST90-AX1705-D25-C25-L150-Z02	25	25	02	150	35	14	AX.T 1705	SSV M4X11	T15
BST90-AX1705-D32-C32-L150-Z03	32	32	03	150	40	14			
BST90-AX1705-D32-C32-L250-Z03	32	32	03	250	70	14			
BST90-AX1235-D16-C14-L120-Z02	16	14	02	120	25	10	AX.T 1235	SSV M3X7	T08
BST90-AX1235-D16-C16-L150-Z02	16	16	02	150	30	10			
BST90-AX1235-D20-C20-L150-Z03	20	20	03	150	40	10			
BST90-AX1235-D20-C20-L150-Z03	20	20	03	150	40	10			
BST90-AX1235-D25-C20-L120-Z04-H	25	20	04	120	30	10			
BST90-AX1235-D25-C25-L150-Z03	25	25	03	150	50	10			

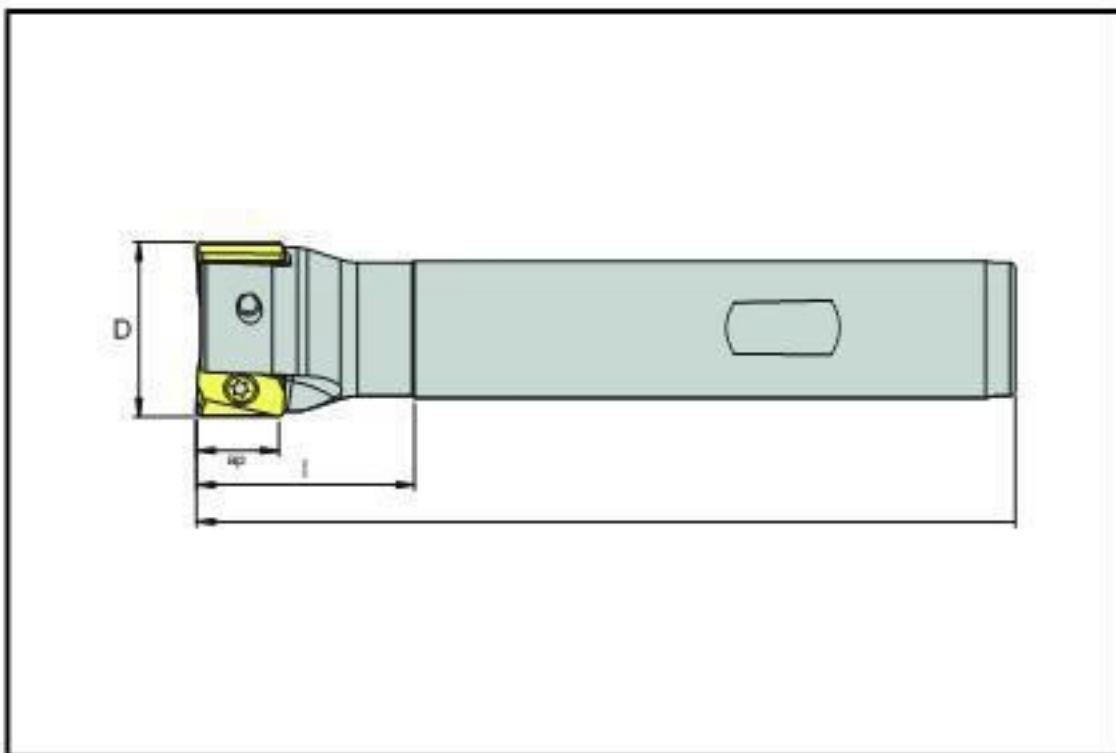

KOD CODE	ÖLÇÜLER DIMENSION (mm)						KESİCİ UÇ INSERT	YEDEK PARÇALAR SPARE PARTS	
	D	d	Z	L	H	ap		Sıkma Vidası Clamp Screw	Anahtar Torx Key
ANMX-16 BST90°									
BST90-AN1607-D32-C25-L150-Z2	32	25	02	150	50	15	AN.X-1607	SSV M4X11	T15
BST90-AN1607-D40-C32-L150-Z2	40	32	03	150	50	15			

S SİSTEM FREZELER

S System end mills

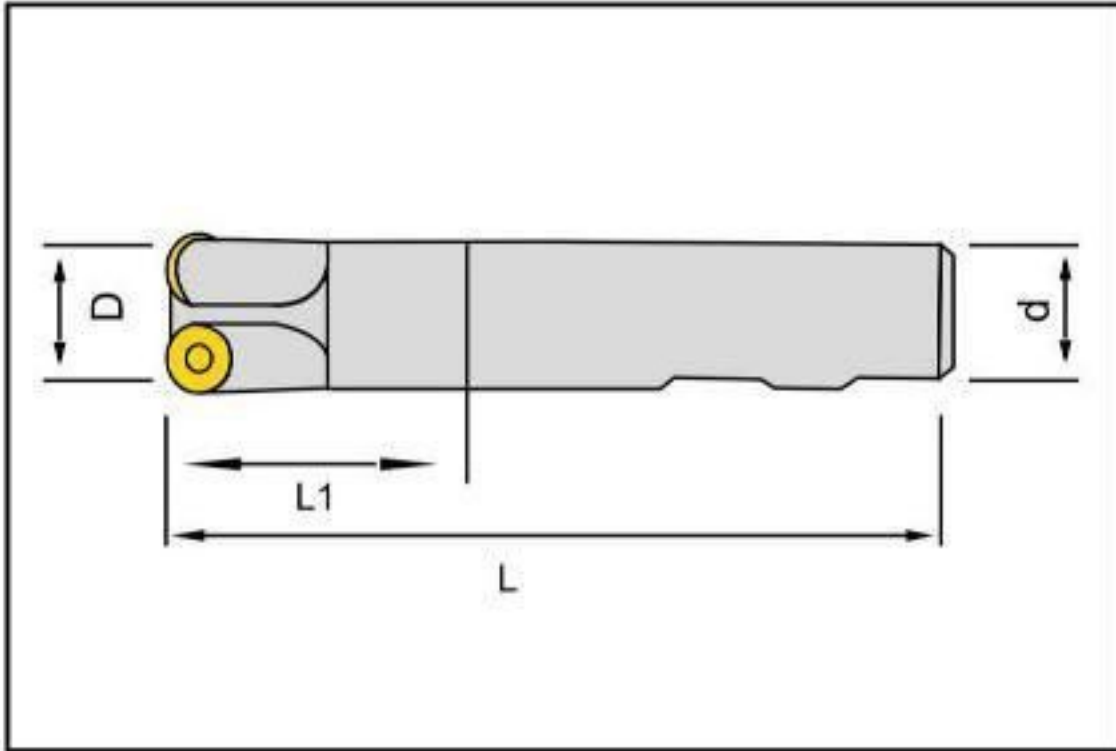

KOD CODE	ÖLÇÜLER DIMENSION (mm)						KESİCİ UÇ INSERT	YEDEK PARÇALAR SPARE PARTS			
	D	d	Z	L	H	ap		Sıkma Vidası Clamp Screw	Baskı Parçası Wedge Clamp	Baskı Vidası Screw	Anahtar Torx Key
RDMT08-10-12 BSTR											
BSTR-RD08-D16-W16-L120-Z02	16	16	02	120	60	04	RD..0803	SSV M2,5X6	-	-	T08
BSTR-RD08-D16-W16-L160-Z02	16	16	02	160	60	04					
BSTR-RD08-D20-W20-L120-Z02	20	20	02	120	60	04					
BSTR-RD08-D20-W20-L160-Z02	20	20	02	160	70	04					
BSTR-RD08-D20-C20-L200-Z02	20	20	02	200	100	04					
BSTR-RD08-D25-W25-L120-Z02	25	25	03	120	60	04					
BSTR-RD08-D25-W25-L160-Z02	25	25	03	160	70	04					
BSTR-RD08-D25-W25-L200-Z02	25	25	03	200	100	04					
BSTR-RD08-D32-W32-L120-Z02	32	32	04	120	60	04					
BSTR-RD08-D32-W32-L160-Z02	32	32	04	160	60	04					
BSTR-RD08-D32-C32-L200-Z02	32	32	04	200	200	04					
BSTR-RD10-D20-W20-L120-Z02	20	20	02	120	60	05	RD..1003	SSV M3,5X9	RTBP-1	T15	T15
BSTR-RD10-D20-W20-L160-Z02	20	20	02	160	60	05					
BSTR-RD10-D20-C20-L200-Z02	20	20	02	200	100	05					
BSTR-RD10-D25-W25-L120-Z02	25	25	02	120	60	05					
BSTR-RD10-D25-W25-L160-Z02	25	25	02	160	70	05					
BSTR-RD10-D25-C25-L200-Z02	32	25	02	200	100	05					
BSTR-RD10-D32-W32-L120-Z02	32	32	03	120	60	05					
BSTR-RD10-D32-W32-L160-Z02	32	32	03	160	70	05					
BSTR-RD10-D32-C32-L200-Z02	32	32	03	200	100	05					
BSTR-RD10-D40-W32-L120-Z04	40	32	04	120	60	05					
BSTR-RD10-D40-W32-L160-Z04	40	32	04	160	70	05					
BSTR-RD10-D40-C32-L200-Z04	40	32	04	200	50	05					
BSTR-RD12-D25-W25-L120-Z02	25	25	02	120	60	06	RD..1203	SSV M3,5X9	RTBP-1	SSV M3,5X9	T15
BSTR-RD12-D25-W25-L160-Z02	25	25	02	160	70	06					
BSTR-RD12-D25-C25-L200-Z02	25	25	02	200	100	06					
BSTR-RD12-D32-W32-L120-Z02	32	32	03	120	60	06					
BSTR-RD12-D32-W32-L160-Z02	32	32	03	160	70	06					
BSTR-RD12-D32-C32-L200-Z02	32	32	03	200	100	06					



BRAX
CUTTING TOOLS
HF30 D20L35 TCM11 M3.5
TOM.16
3007

BRAX
CUTTING TOOLS
ST90 AP16 D32 L120 Z3
M3.5
T118
3000

BRAX
CUTTING TOOLS
S190 AP16 D30 L150 Z3
M3.5
T118
3000

BRAX
CUTTING TOOLS
ST90 AP10 D22 L200 Z3
M3.5
T118
3000

BRAX
CUTTING TOOLS
T590 CC06 D30 L120 Z1
M3.5
T118
3000

BRAX
CUTTING TOOLS
T590 CC06 D30 L120 Z1
M3.5
T118
3000

BRAX
CUTTING TOOLS
ST00 AP10 D25 L120 Z3
M3.5
T118
3000

KÜRE UÇLU PARMAK FREZELER

Ball Nose end Mills

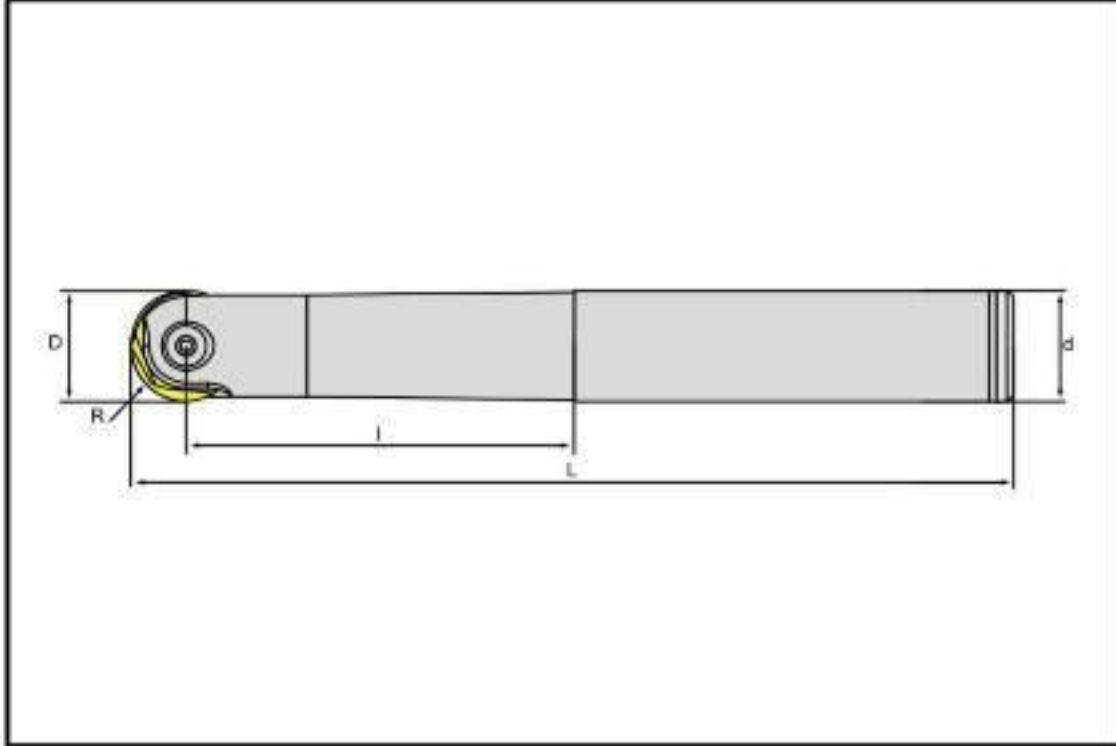

KOD CODE	ÖLÇÜLER DIMENSION (mm)					KESİCİ UÇ INSERT	YEDEK PARÇALAR SPARE PARTS	
	D	r	L	d	H		Sıkma Vidası Clamp Screw	Anahtar Allen Key
KÜRE UÇLU TARAMALAR BSRT P32..								
BSRT-P3208-D08-L130-d10	8	4	110	10	25	P3208	TC 170 3X7	T08
BSRT-P3210-D10-L130-d12	10	5	130	12	30	P3210	TC 172 4X0,5X9	T15
BSRT-P3212-D12-L150-d12	12	6	130	12	32	P3212	TC 174 5X0,5X9	T20
BSRT-P3216-D16-L175-d16	16	8	175	16	60	P3216	TC 176 5X0,5X12	T20
BSRT-P3220-D20-L200-d20	20	10	200	20	100	P3220	TC 178 5X0,5X12	T20
BSRT-P3225-D25-L200-d25	25	12,5	200	25	100	P3225	TC 181 6X0,75X20	AA3
BSRT-P3232-D32-L200-d32	32	16	200	32	100	P3232	TC 184 8X0,75X24	AA4

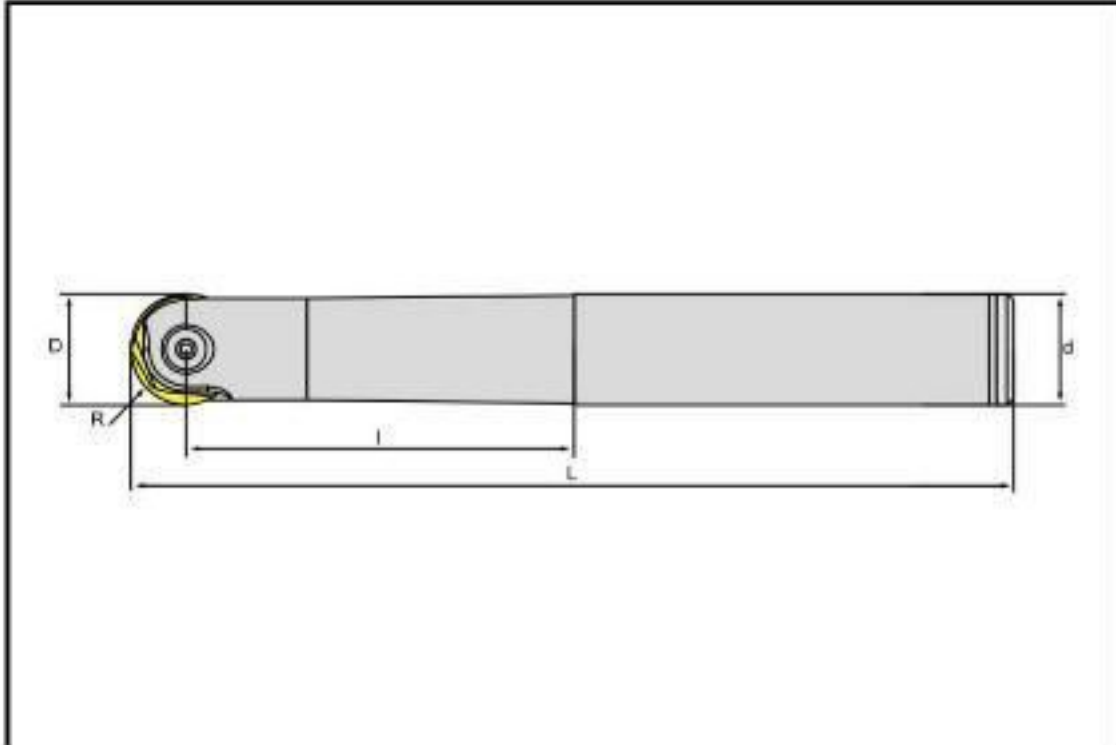

KOD CODE	ÖLÇÜLER DIMENSION (mm)					KESİCİ UÇ INSERT	YEDEK PARÇALAR SPARE PARTS	
	D	r	L	d	H		Sıkma Vidası Clamp Screw	Anahtar Allen Key
KÜRE UÇLU TARAMALAR BSRT-ROHX								
BSRT-ROHX1203-D12-L120-d12	12	6	12	120	35	ROHX 1203	TC 172 4X0,5X9	T15
BSRT-ROHX1203-D12-L160-d16	12	6	16	160	50			
BSRT-ROHX1604-D16-L160-d16	16	8	16	160	45	ROHX 1604	TC 176 5X0,5X12	
BSRT-ROHX1604-D16-L200-d20	16	8	20	200	65	ROHX2005	TC 176 5X0,5X15	
BSRT-ROHX2005-D20-L160-d20	20	10	20	160	55			
BSRT-ROHX2005-D20-L220-d25	20	10	25	220	80			



T KANAL FREZELER

T SYSTEM MILLING

TF90 GC06 D30x12 L120 Z1
B-AX
CUTTING TOOLS
PMS
T08

B-AX
CUTTING TOOLS
TF90 GC05 D25x10 Z1 L120
PMS
T08

100513
T08

T KANAL FREZELER

T System Milling

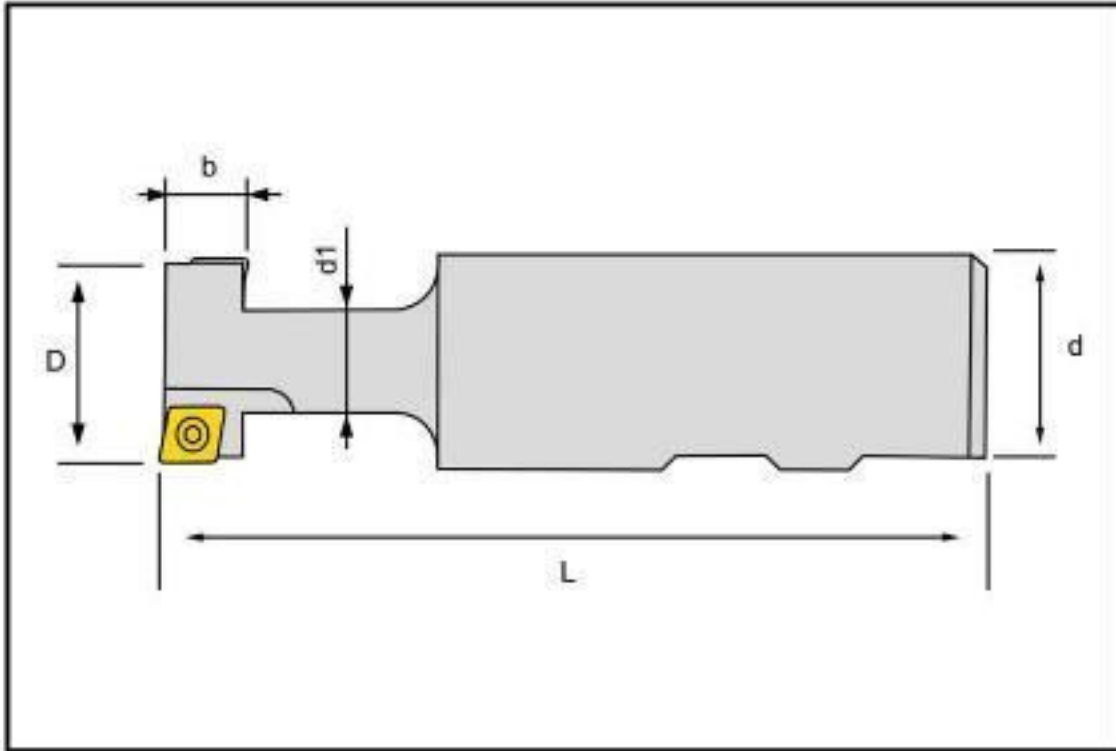

KOD CODE	ÖLÇÜLER DIMENSION (mm)					KESİCİ UÇ INSERT	YEDEK PARÇALAR SPARE PARTS	
	D	ap	T _{max}	d	Z		Sıkma Vidası Clamp Screw	Anahtar Torx Key
TK90° T FREZELER								
TF90 CC06 D17x8 L100 Z02	17	08	3.5	16	2	CC 06 02..	SSV M2,5x5	T08
TF90 CC06 D20x9 L100 Z02	20	09	5	16	2			
TF90 CC06 D23x10 L120 Z02	23	10	4.5	20	2			
TF90 CC06 D25x10 L120 Z04	25	10	4.5	20	2			
TF90 CC06 D30x12 L120 Z04	30	12	6	25	4			
TF90 CC06 D32x12 L120 Z04	32	12	7	25	4			
TF90 CC06 D35x12 L120 Z04	35	12	10	25	4			
TF90 CC09 D42x14 L120 Z04	42	14	10	25	4	CC 09 T3	SSV M3,5x9	T08
TF90 CC09 D45x14 L120 Z04	45	14	10	32	4	CC 06 02..	SSV M2,5x7,5	T08
TF90 CC06 D45x8 L120 Z06	45	08	10	32	6			
TF90 CC06 D45x10 L120 Z06	45	10	10	32	6			
TF90 CC06 D50x8 L120 Z08	50	08	12	32	6			
TF90 CC06 D50x10 L120 Z08	50	10	12	32	6			
TF90 CC06 D55x8 L120 Z08	55	08	15	32	8			
TF90 CC06 D55x10 L120 Z08	55	10	15	32	8			
TF90 CC06 D60x8 L120 Z08	60	08	17	32	8			
TF90 CC06 D60x10 L120 Z08	60	10	17	32	8			
TF90 CC12 D47x20 L120 Z08	47	20	17	32	4			

DİSK FREZELER

Disc Milling

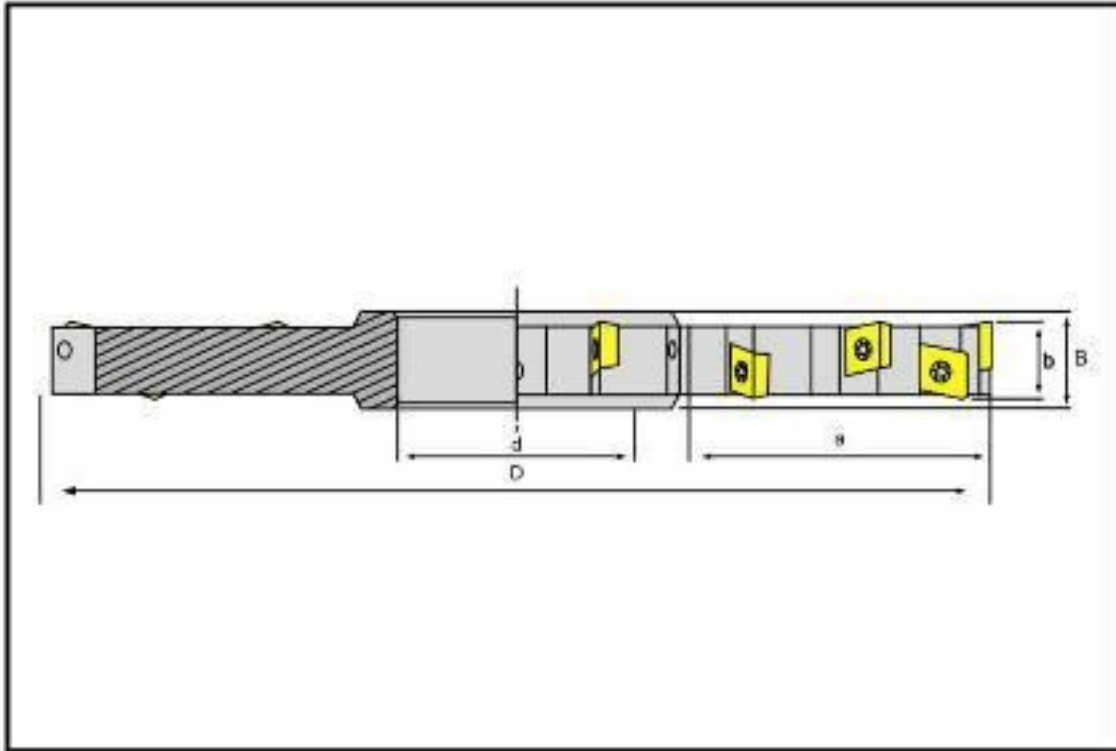

KOD CODE	ÖLÇÜLER DIMENSION (mm)					KESİCİ UÇ INSERT	YEDEK PARÇALAR SPARE PARTS	
	D	ap	T _{max}	d	Z		Sıkma Vidası Clamp Screw	Anahtar Torx Key
DİSK FREZELER								
BSDF CC06 D60x8 d27 Z08	60	8	15	22	10	CC 06 02..	SSV M2,5x7,5	T08
BSDF CC06 D80x8 d27 Z10	80	8	17	27	10			
BSDF CC06 D100x8 d32 Z12	100	8	25	32	12			
BSDF CC06 D125x8 d40 Z14	125	8	35	40	14			
BSDF CC06 D60x10 d27 Z08	60	10	14	27	8			
BSDF CC06 D80x10 d27 Z10	80	10	17	27	10			
BSDF CC06 D100x10 d32 Z12	100	10	25	32	12			
BSDF CC06 D125x10 d40 Z14	125	10	35	40	14			
BSDF CC06 D160x10 d40 Z16	160	10	52	40	16	CC 09 T3	SSV M3,5x9	T15
BSDF CC09 D80X12 d27 Z10	80	12	17	27	8			
BSDF CC09 D100X12 d32 Z12	100	12	25	32	10			
BSDF CC09 D125X12 d40 Z14	125	12	35	40	12			
BSDF CC09 D160X12 d40 Z16	160	12	52	40	14			
BSDF CC09 D80x14 d27 Z10	80	14	17	27	8			
BSDF CC09 D100x14 d32 Z12	100	14	25	32	10			
BSDF CC09 D125x14 d40 Z14	125	14	35	40	12			
BSDF CC09 D160x14 d40 Z16	160	14	52	40	14			



S SİSTEM PAH FREZELER

S System Chamfering and Mills

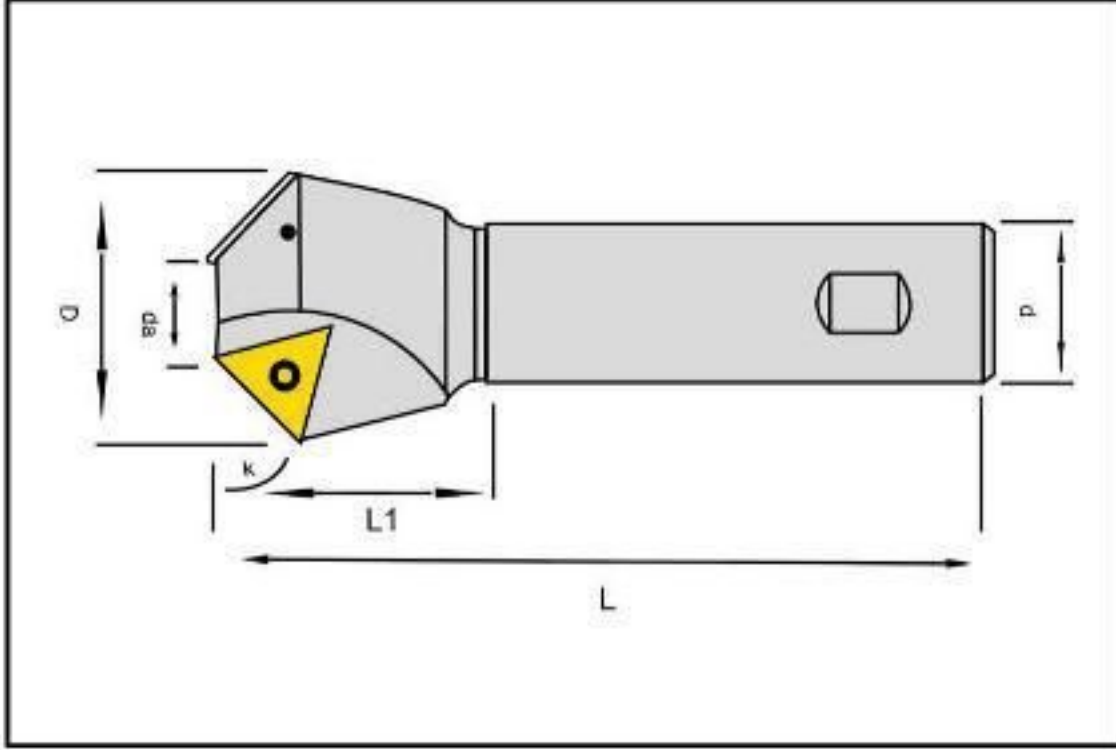

KOD CODE	ÖLÇÜLER DIMENSION (mm)						KESİCİ UÇ INSERT	YEDEK PARÇALAR SPARE PARTS	
	D1° D2°	D1	D2	L	Z	ap		Sıkma Vidası Clamp Screw	Anahtar Torx Key
HAVŞA FREZELER									
HF45 TC11 D4-15 L100 Z01	45°	4	15	100	01	16	TCM 11 02..	SSV M2,5x5	T08
HF45 TC16 D10-31 L100 Z02	45°	10	31	100	02	16	TCM 16 T3..	SSV M3,5X7,5	T15
HF45 TC16 D14-35 L100 Z02	45°	14	35	100	02	16			
HF45 TC16 D22-43 L100 Z03	45°	22	43	100	03	16			
HF45 TC16 D32-58 L100 Z04	45°	32	58	100	04	16			
HF30 TC16 D30-45 L100 Z02	30°	30	45	100	02	16			
HF30 TC16 D20-35 L100 Z02	30°	20	35	100	02	16			
HF30 TC16 D6-20 L100 Z01	30°	6	20	100	01	16			
HF25 TC16 D17-30 L100 Z01	25°	17	30	100	01	16			
HF22,5 TC16 D17-28 L100 Z01	22,5°	17	28	100	01	16			
HF20 TC16 D17-26 L100 Z01	20°	17	26	100	01	16			
HF20 TC16 D12-20 L100 Z01	20°	12	20	100	01	16			
HF17,5 TC16 D17-24 L100 Z01	17,5°	17	24	100	01	16			
HF15 TC16 D17-22 L100 Z01	15°	17	22	100	01	16			
HF10 TC16 D18-21 L100 Z01	10°	18	21	100	01	16			

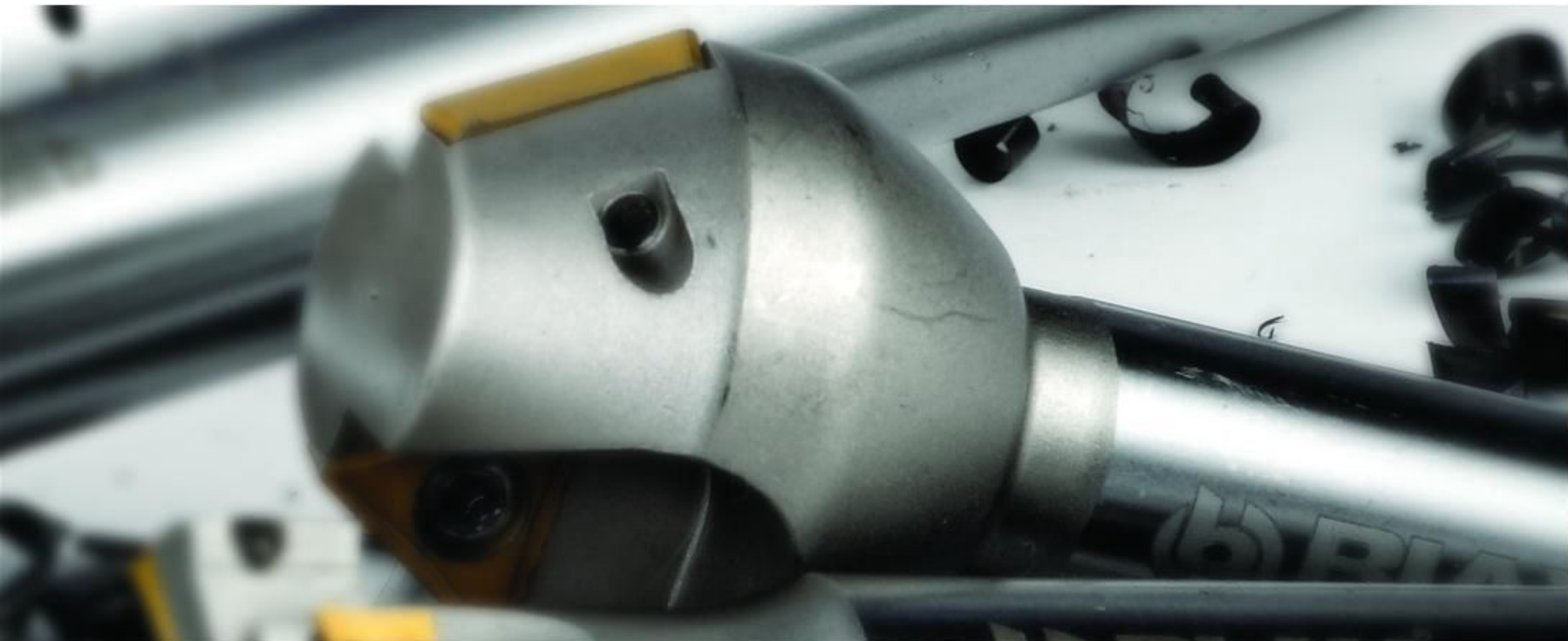

S SİSTEM MODÜLER FREZELER

S System Modular and Mills

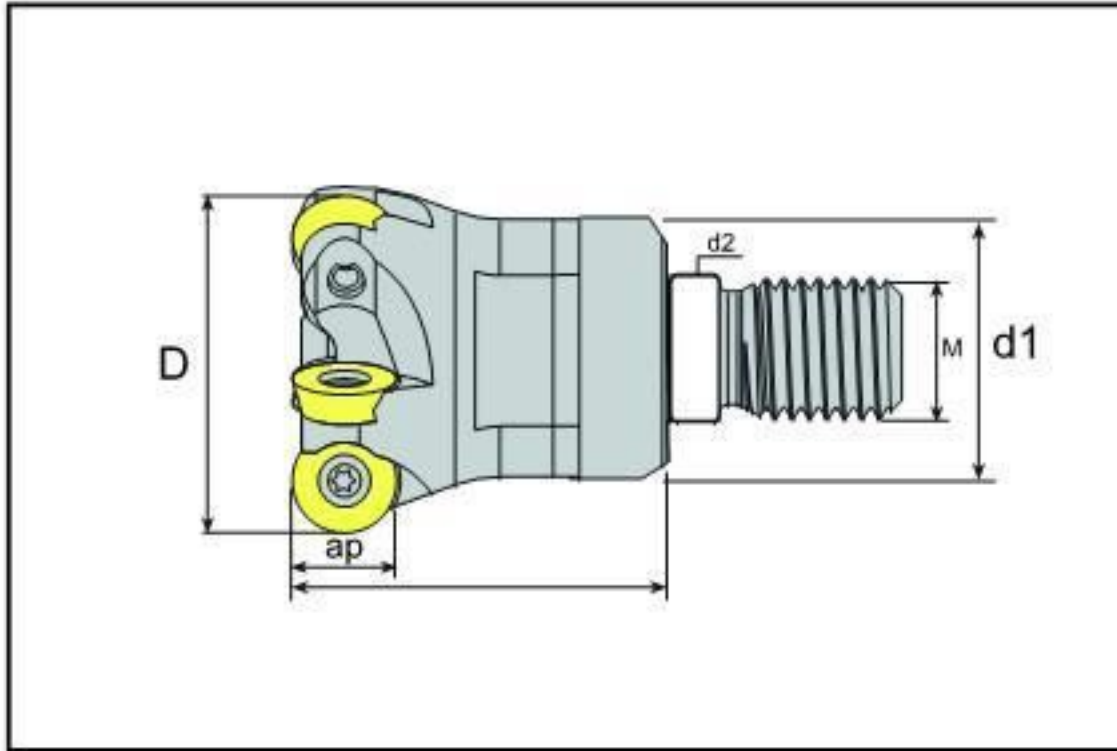

KOD CODE	ÖLÇÜLER DIMENSION (mm)						KESİCİ UÇ INSERT	YEDEK PARÇALAR SPARE PARTS	
	D	Z	d1	d2	L	ap		Sıkma Vidası Clamp Screw	Anahtar Torx Key
MODÜLER FREZELER RDMT									
MT-RD10-D20-M10-L30-Z02-H	20	2	18	10,5	30	5	RD..1003..	SSV M3,5x7,5	T15
MT-RD10-D25-M12-L35-Z03-H	25	3	21	12,5	35	5			
MT-RD10-D30-M16-L43-Z04-H	30	4	29	17	43	5			
MT-RD10-D32-M16-L43-Z04-H	32	4	29	17	43	5			
MT-RD10-D35-M16-L43-Z04-H	35	4	29	17	43	5			
MT-RD10-D40-M16-L43-Z05-H	40	5	29	17	43	5			
MT-RD10-D42-M16-L43-Z05-H	42	5	29	17	43	5			
MT-RD12-D24-M12-L35-Z02-H	24	2	21	12,5	35	6	RD..12T3..	SSV M3,5x7,5	T15
MT-RD12-D25-M12-L35-Z02-H	25	2	21	12,5	35	6			
MT-RD12-D32-M16-L43-Z03-H	32	3	29	17	43	6			
MT-RD12-D35-M16-L43-Z04-H	35	4	29	17	43	6			
MT-RD12-D40-M16-L43-Z04-H	40	4	29	17	43	6			
MT-RD12-D42-M16-L43-Z05-H	42	5	29	17	43	6			

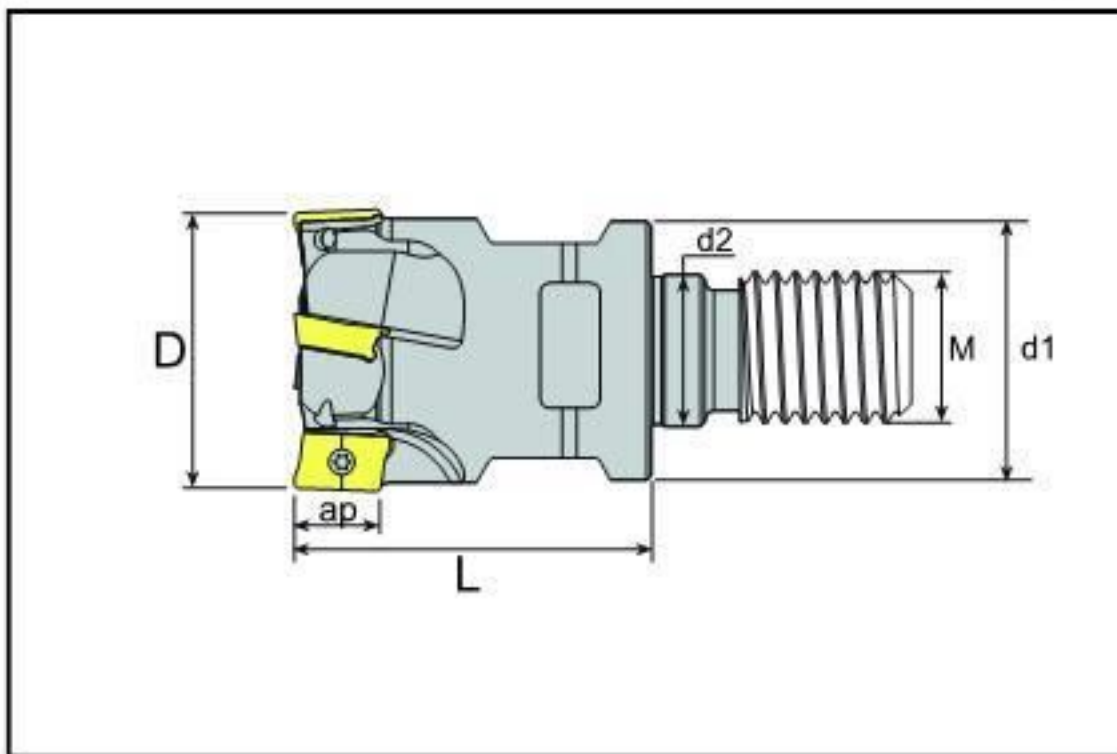



KOD CODE	ÖLÇÜLER DIMENSION (mm)						KESİCİ UÇ INSERT	YEDEK PARÇALAR SPARE PARTS	
	D	Z	d1	d2	L	ap		Sıkma Vidası Clamp Screw	Anahtar Torx Key
MODÜLER FREZELER APKT									
MT90-AP10-D16-M08-L30-Z02-H	16	2	14,75	8,5	30	10	AP.1003..	SSV M2,5x6	T15
MT90-AP10-D20-M10-L30-Z03-H	20	3	18	10,5	30	10			
MT90-AP10-D25-M12-L35-Z03-H	25	3	21	12,5	35	10			
MT90-AP10-D32-M16-L35-Z04-H	32	4	29	17	43	10			
MT90-AP10-D40-M16-L43-Z05-H	40	5	29	17	43	10			
MT90-AP10-D42-M16-L43-Z05-H	42	5	29	17	43	10			

S SİSTEM HELİSEL FREZELER

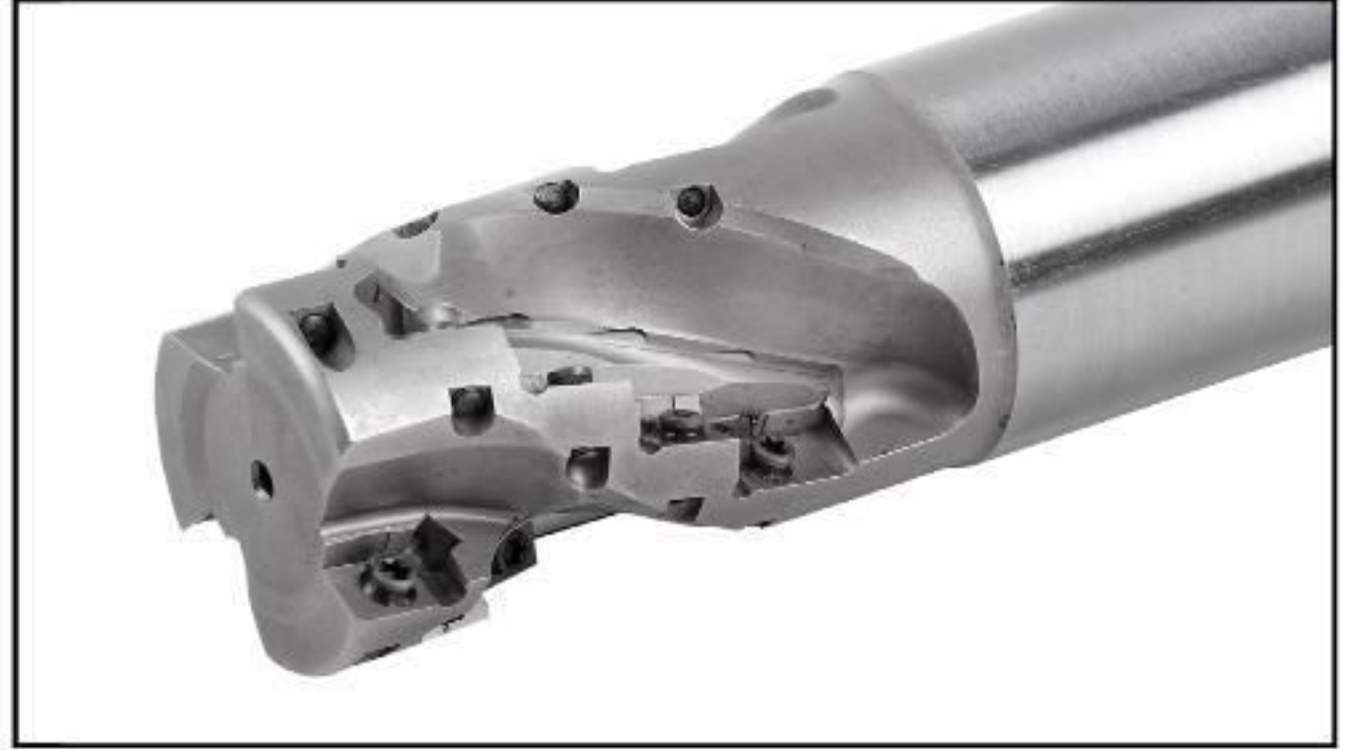
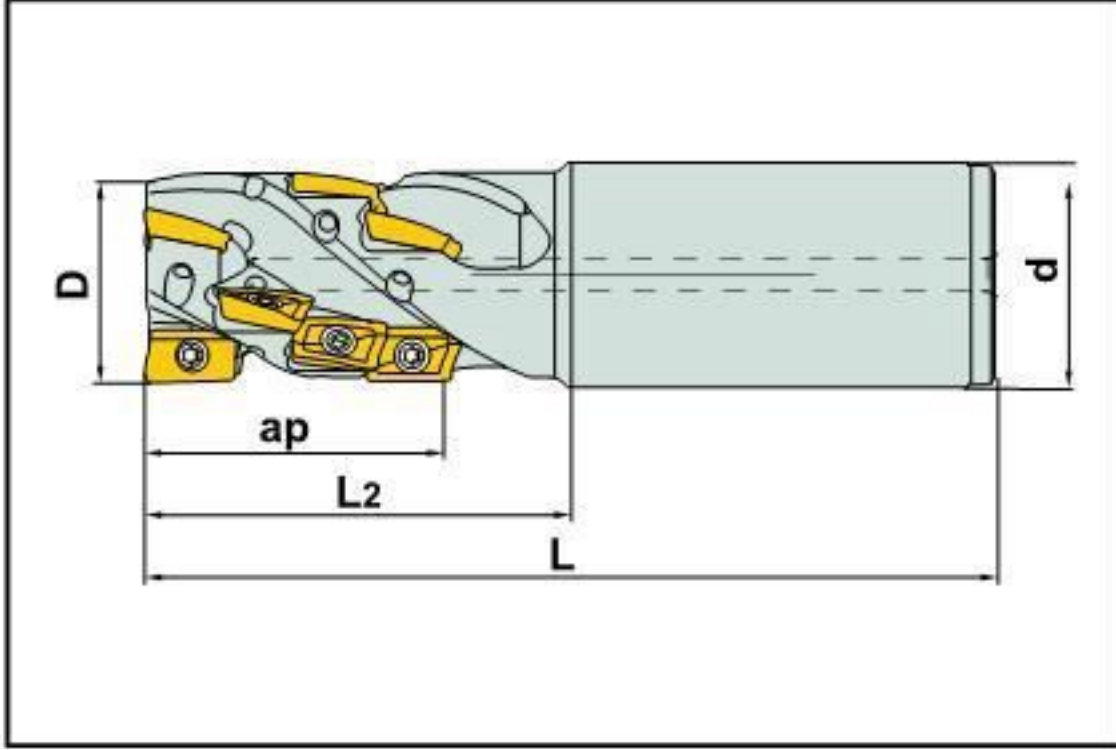
S System Helix end Mills



KOD CODE	ÖLÇÜLER DIMENSION (mm)					KESİCİ UÇ INSERT	YEDEK PARÇALAR SPARE PARTS	
	D	Z	d	L	ap		Sıkma Vidası Clamp Screw	Anahtar Torx Key
TK90° HELİSEL FREZELER						 AP.. 1003		
HT90-AP10-D20-L87-A20-Z06	20	6	20	87	28		SSV M2,5X7,5	T08
HT90-AP10-D25-L105-A25-Z08	25	8	25	105	37			
HT90-AP10-D32-L115-A32-Z15	32	15	32	115	46			
HT90-AP10-D40-L130-A32-Z18-H	40	18	32	130	55			

S SİSTEM KIRLANGIÇ FREZELER

S System Helix end Mills

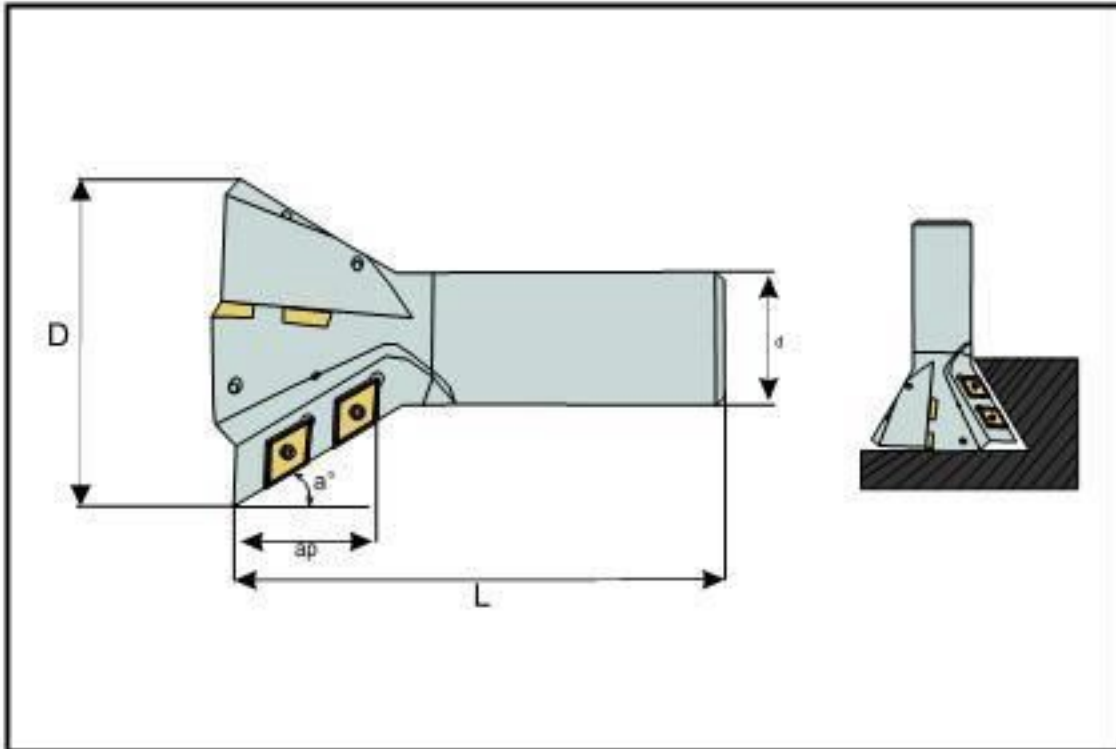

KOD CODE	ÖLÇÜLER DIMENSION (mm)					KESİCİ UÇ INSERT	YEDEK PARÇALAR SPARE PARTS	
	D	Z	d	L	a°		Sıkma Vidası Clamp Screw	Anahtar Torx Key
KIRLANGIÇ TAKIMLAR						 DC.11 T3..		
BKRF60-DC11-D31.96-L120-Z02	31,96	2	32	120	60		SSV M3,5x7,5	T15
BKRF60-DC11-D40.05-L120-Z02	40,05	2	32	120	60			
BKRF60-DC11-D50-L120-Z04	50	4	40	120	60			
BKRF55-DC11-D60-L120-Z04	60	4	40	120	55			
BKRF60-DC11-D80-L120-Z04	80	4	40	120	60			

YÜZEY FREZELER

FACE MILLING CUTTER



YÜZEY FREZELER

Face Milling Cutter

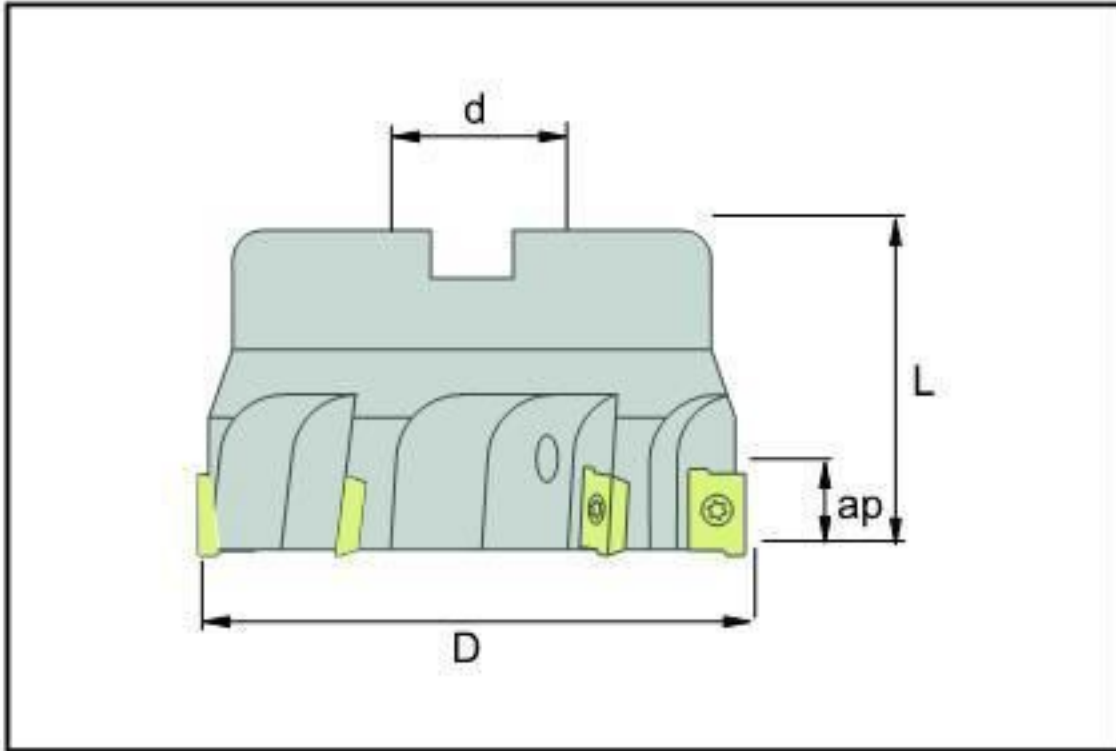

KOD CODE	ÖLÇÜLER DIMENSION (mm)					KESİCİ UÇ INSERT	YEDEK PARÇALAR SPARE PARTS	
	D	Z	d	L	ap		Sıkma Vidası Clamp Screw	Anahtar Torx Key
TK90° APKT-10						 AP. 1003..		
TK90-AP10-D40-A16-Z05-H	40	5	16	40	10		SSV M3,5x7,5	T08
TK90-AP10-D50-A22-Z06-H	50	6	22	40	10			
TK90-AP10-D63-A22-Z07-H	63	7	22	40	10			
TK90-AP10-D80-A27-Z08-H	80	8	27	50	10			
TK90-AP10-D100-A32-Z09-H	100	9	32	50	10			

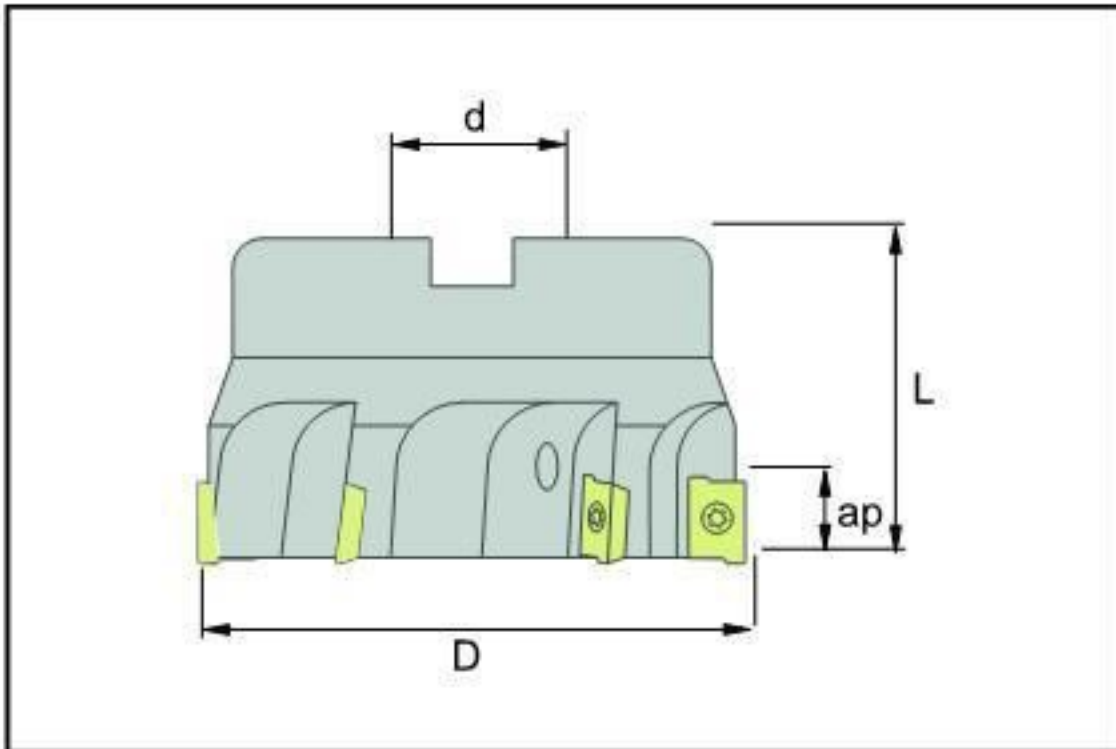

KOD CODE	ÖLÇÜLER DIMENSION (mm)					KESİCİ UÇ INSERT	YEDEK PARÇALAR SPARE PARTS	
	D	Z	d	L	ap		Sıkma Vidası Clamp Screw	Anahtar Torx Key
TK90° APKT-16						 AP. 1604..		
TK90-AP16-D40-A16-Z04-H	40	4	16	40	16		SSV M3,5x11	T15
TK90-AP16-D50-A22-Z05-H	50	5	22	40	16			
TK90-AP16-D63-A22-Z06-H	63	6	22	40	16			
TK90-AP16-D80-A27-Z07-H	80	7	27	50	16			
TK90-AP16-D100-A32-Z08-H	100	8	32	50	16			
TK90-AP16-D125-B40-Z09	125	9	40	63	16			
TK90-AP16-D160-C40-Z10	160	10	40	63	16			

YÜZEY FREZELER Face Milling Cutter

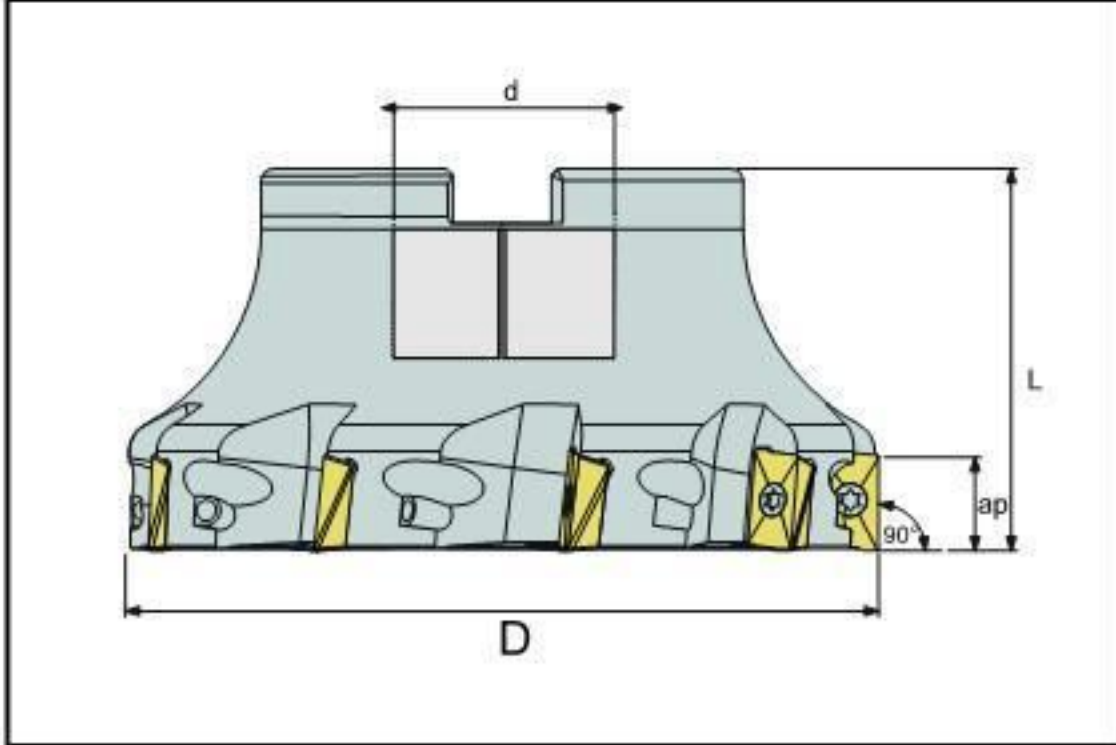

KOD CODE	ÖLÇÜLER DIMENSION (mm)					KESİCİ UÇ INSERT	YEDEK PARÇALAR SPARE PARTS	
	D	Z	d	L	ap		Sıkma Vidası Clamp Screw	Anahtar Torx Key
TK90° ADKT-15								
TK90-AD1505-D40-A16-Z04-H	40	4	16	40	15	AD. 1505..	SSV M4x11	T15
TK90-AD1505-D50-A22-Z05-H	50	5	22	40	15			
TK90-AD1505-D63-A22-Z06-H	63	6	22	40	15			
TK90-AD1505-D80-A27-Z07-H	80	7	27	50	15			
TK90-AD1505-D100-A32-Z08-H	100	8	32	50	15			
TK90-AD1505-D125-B40-Z09	125	9	40	63	15			

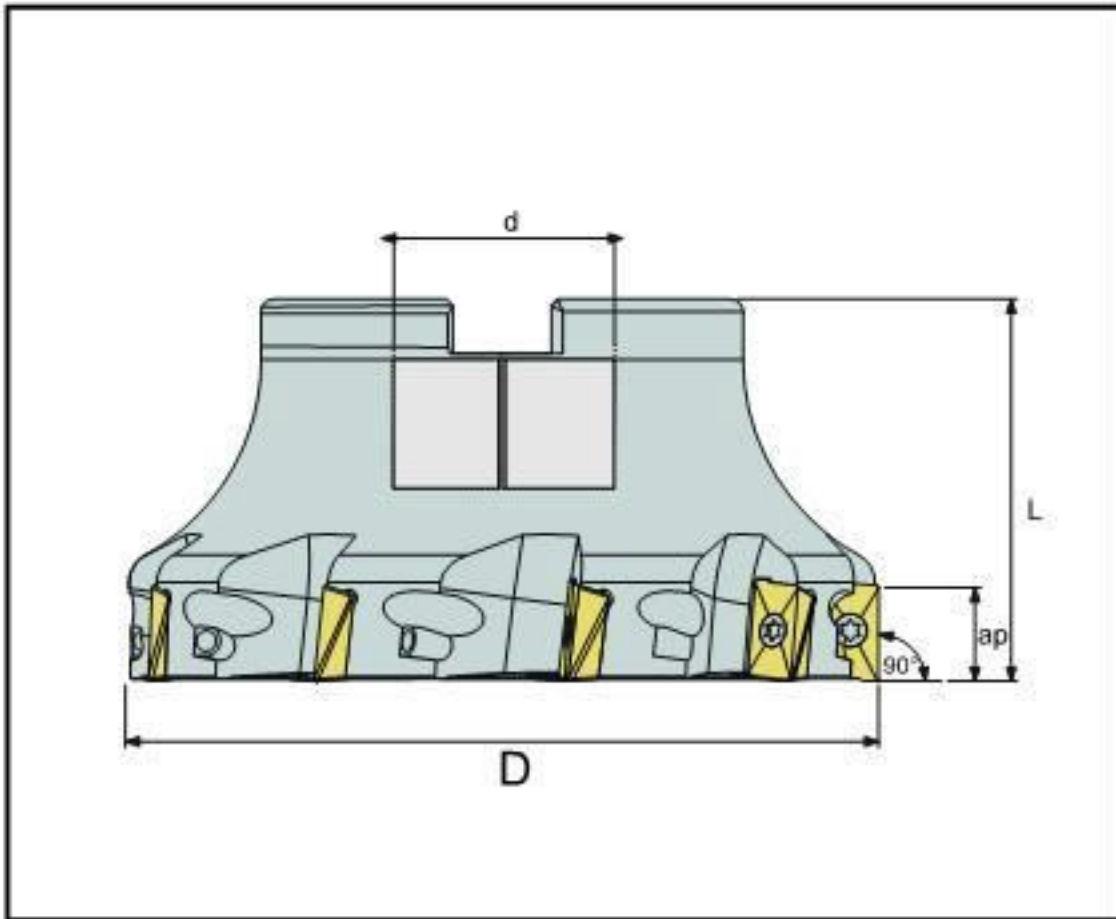

KOD CODE	ÖLÇÜLER DIMENSION (mm)					KESİCİ UÇ INSERT	YEDEK PARÇALAR SPARE PARTS	
	D	Z	d	L	ap		Sıkma Vidası Clamp Screw	Anahtar Torx Key
TK90° R390.11T3-R390.17T4								
TK90-R390.11-D40-A16-Z05-H	40	5	16	40	11	R390.11T3	SSV M2,5x7,5	T08
TK90-R390.11-D50-A22-Z06-H	50	6	22	40	11			
TK90-R390.11-D63-A22-Z07-H	63	7	22	40	11			
TK90-R390.17-D40-A16-Z04-H	40	4	16	40	17	R390.17T4	SSV M3,5x9	T15
TK90-R390.17-D50-A22-Z05-H	50	5	22	40	17			
TK90-R390.17-D63-A22-Z06-H	63	6	22	40	17			
TK90-R390.17-D80-A27-Z07-H	80	7	27	50	17			
TK90-R390.17-D100-A32-Z08-H	100	8	32	50	17			
TK90-R390.17-D125-D40-Z09	125	9	40	63	17			

YÜZEY FREZELER Face Milling Cutter

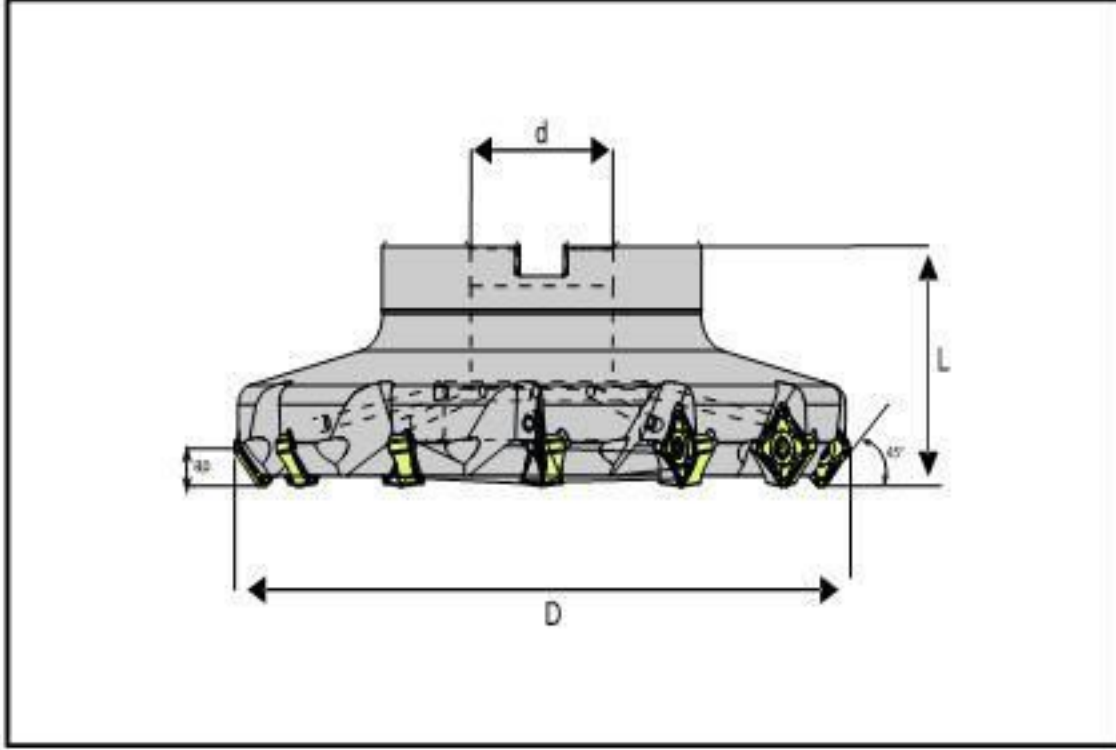

KOD CODE	ÖLÇÜLER DIMENSION (mm)					KESİCİ UÇ INSERT	YEDEK PARÇALAR SPARE PARTS	
	D	Z	d	L	ap		Sıkma Vidası Clamp Screw	Anahtar Torx Key
TK45° SN-1206								
TK45C-SN1206-D50-A22-Z05-H	50	5	22	40	6	SN-1206	SSV M4x11	T15
TK45C-SN1206-D63-A22-Z07-H	63	7	22	40	6			
TK45C-SN1206-D80-A27-Z08-H	80	8	27	50	6			
TK45C-SN1206-D100-A32-Z10-H	100	10	32	50	6			
TK45C-SN1206-D125-B40-Z11	125	11	40	63	6			
TK45C-SN1206-D160-C40-Z12	160	12	40	63	6			
TK45C-SN1206-D200-C60-Z14	200	14	60	63	6			

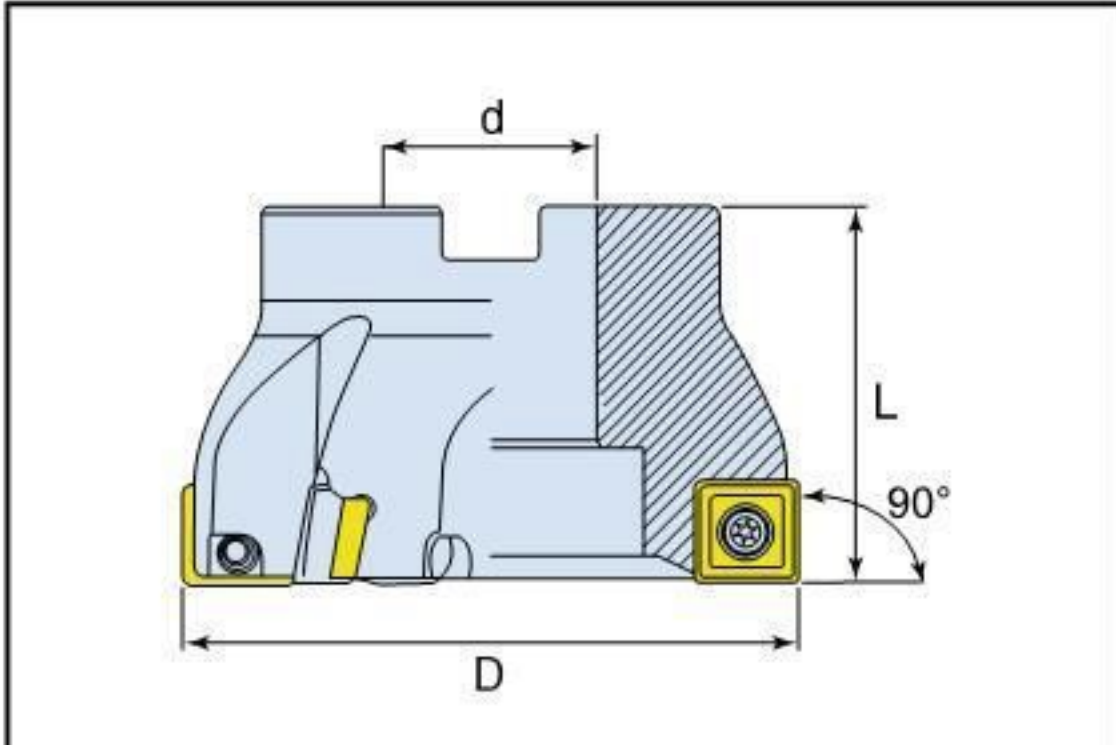

KOD CODE	ÖLÇÜLER DIMENSION (mm)					KESİCİ UÇ INSERT	YEDEK PARÇALAR SPARE PARTS	
	D	Z	d	L	ap		Sıkma Vidası Clamp Screw	Anahtar Torx Key
TK90° R290 - 12T3								
TK90-R290.12-D50-A22-Z04-H	50	4	22	40	12	R290 - 12T3	SSV M3,5x9	T15
TK90-R290.12-D63-A22-Z05-H	63	5	22	40	12			
TK90-R290.12-D80-A27-Z07-H	80	7	27	50	12			
TK90-R290.12-D100-A32-Z09-H	100	9	32	50	12			
TK90-R290.12-D125-B40-Z11	125	11	40	63	12			

YÜZEY FREZELER Face Milling Cutter

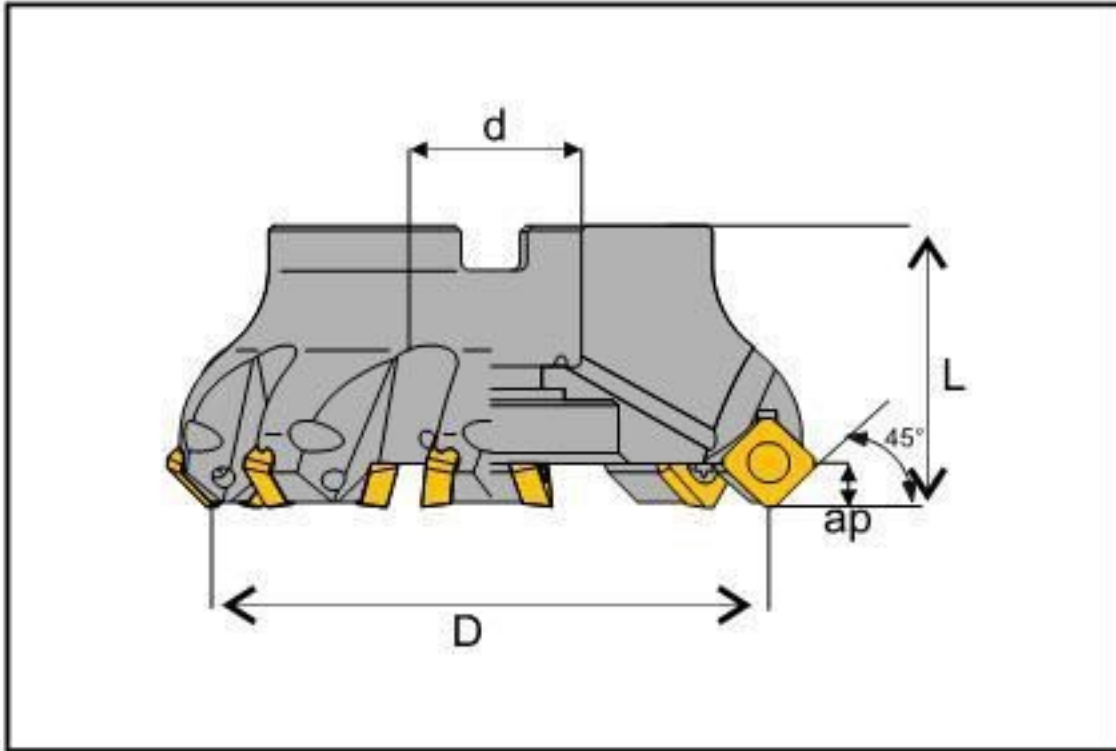

KOD CODE	ÖLÇÜLER DIMENSION (mm)					KESİCİ UÇ INSERT	YEDEK PARÇALAR SPARE PARTS	
	D	Z	d	L	ap		Sıkma Vidası Clamp Screw	Anahtar Torx Key
TK45° SE-12T3								
TK45C-SE12T3-D50-A22-Z04-H	40	4	22	40	6	SE 12T3	SSV M3,5x9	T15
TK45C-SE12T3-D63-A22-Z05-H	63	5	22	40	6			
TK45C-SE12T3-D80-A27-Z06-H	80	6	27	50	6			
TK45C-SE12T3-D100-A32-Z07-H	100	7	32	50	6			
TK45C-SE12T3-D125-B40-Z08	125	8	40	63	6			
TK45C-SE12T3-D160-C40-Z10	160	10	40	63	6			
TK45C-SE12T3-D200-C60-Z12	200	12	60	63	6			

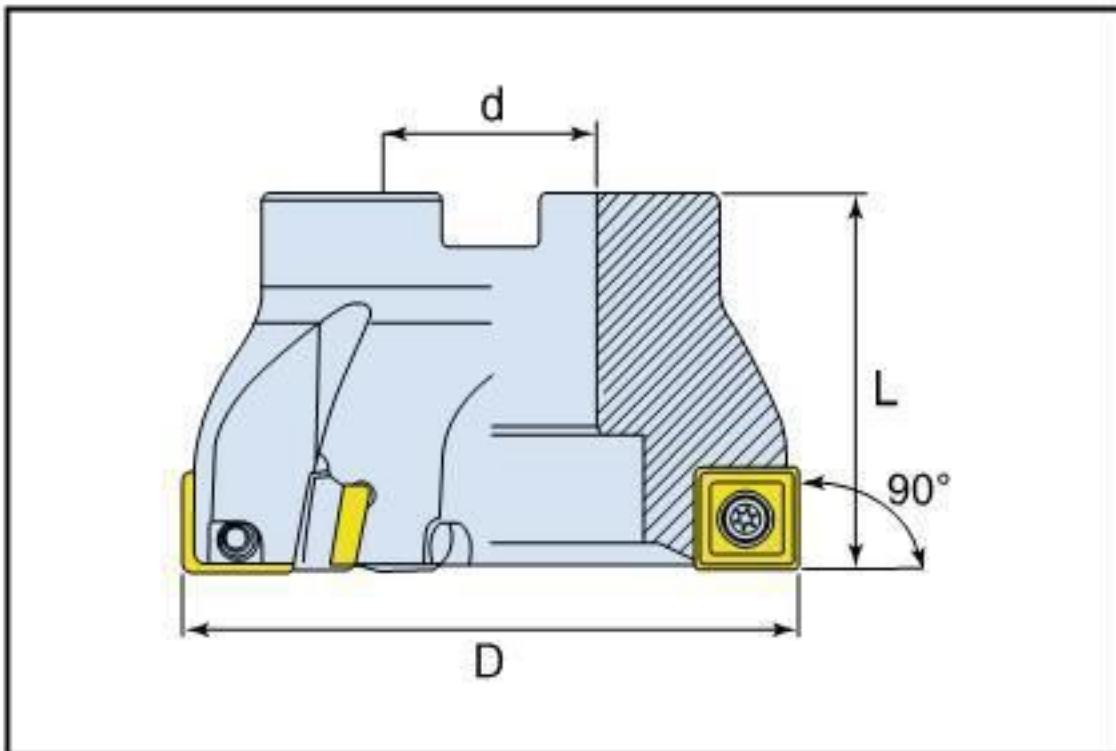

KOD CODE	ÖLÇÜLER DIMENSION (mm)					KESİCİ UÇ INSERT	YEDEK PARÇALAR SPARE PARTS	
	D	Z	d	L	ap		Sıkma Vidası Clamp Screw	Anahtar Torx Key
TK90° SD-1305								
TK90C-SD1305-D50-A22-Z04-H	50	4	22	40	12	SD 1305	SSV M5x11	T20
TK90C-SD1305-D63-A22-Z05-H	63	5	22	40	12			
TK90C-SD1305-D80-A27-Z06-H	80	7	27	50	12			
TK90C-SD1305-D100-A32-Z07-H	100	9	32	50	12			

YÜZEY FREZELER Face Milling Cutter

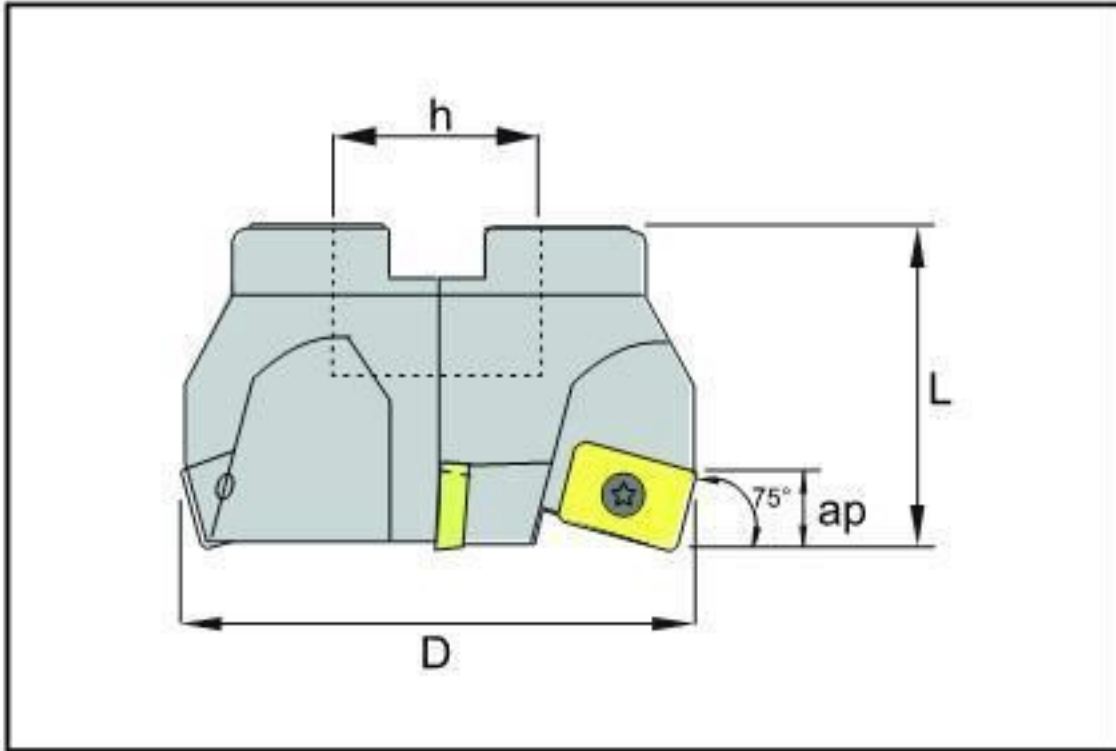

KOD CODE	ÖLÇÜLER DIMENSION (mm)					KESİCİ UÇ INSERT	YEDEK PARÇALAR SPARE PARTS	
	D	Z	d	L	ap		Sıkma Vidası Clamp Screw	Anahtar Torx Key
TK75° APKT-16								
TK75C-AP16-D63-A22-03	63	3	22	40	10	APKT-16	SSV M3,5X9	T15
TK75C-AP16-D80-A27-04	80	4	27	40	10			
TK75C-AP16-D100-A32-06	100	6	32	50	10			
TK75C-AP16-D125-B40-07	125	7	40	63	10			

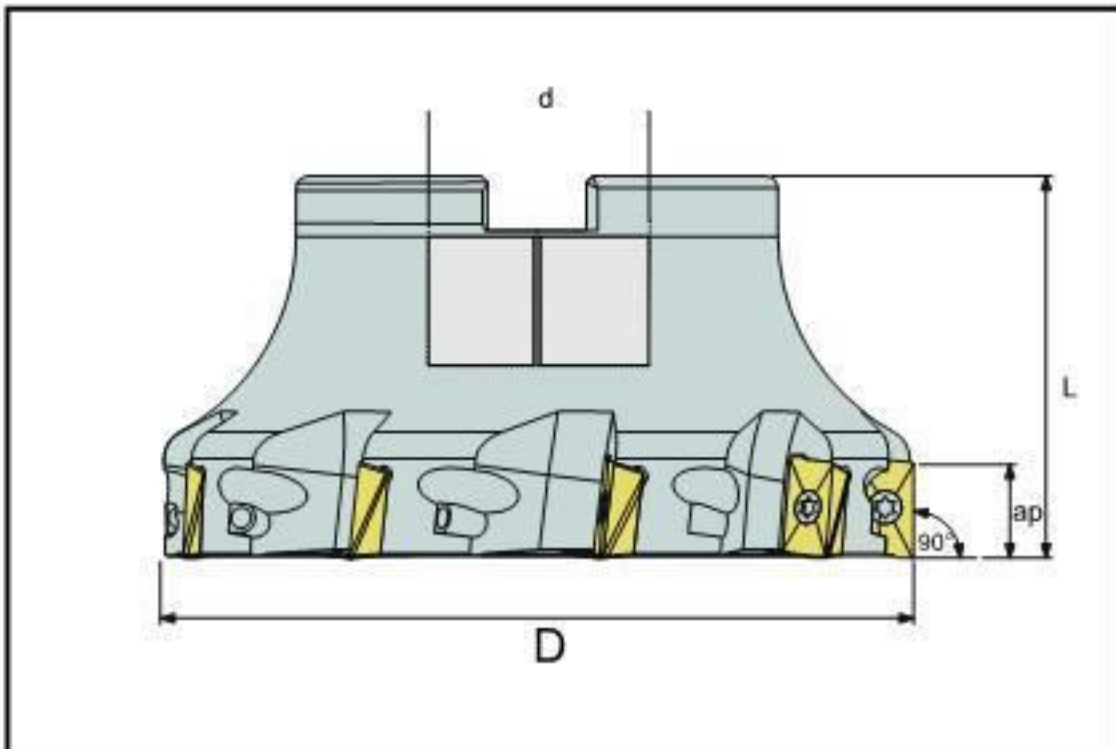

KOD CODE	ÖLÇÜLER DIMENSION (mm)					KESİCİ UÇ INSERT	YEDEK PARÇALAR SPARE PARTS	
	D	Z	d	L	ap		Sıkma Vidası Clamp Screw	Anahtar Torx Key
TK90° XO..1204								
TK90C-XO12-D40-A16-Z05-H	40	5	16	40	11	XO.1204	SSV M3,5X9	T15
TK90C-XO12-D50-A22-Z07-H	50	7	22	40	11			
TK90C-XO12-D63-A22-Z08-H	63	8	22	40	11			
TK90C-XO12-D80-A27-Z10-H	80	10	27	50	11			

YÜZEY FREZELER Face Milling Cutter

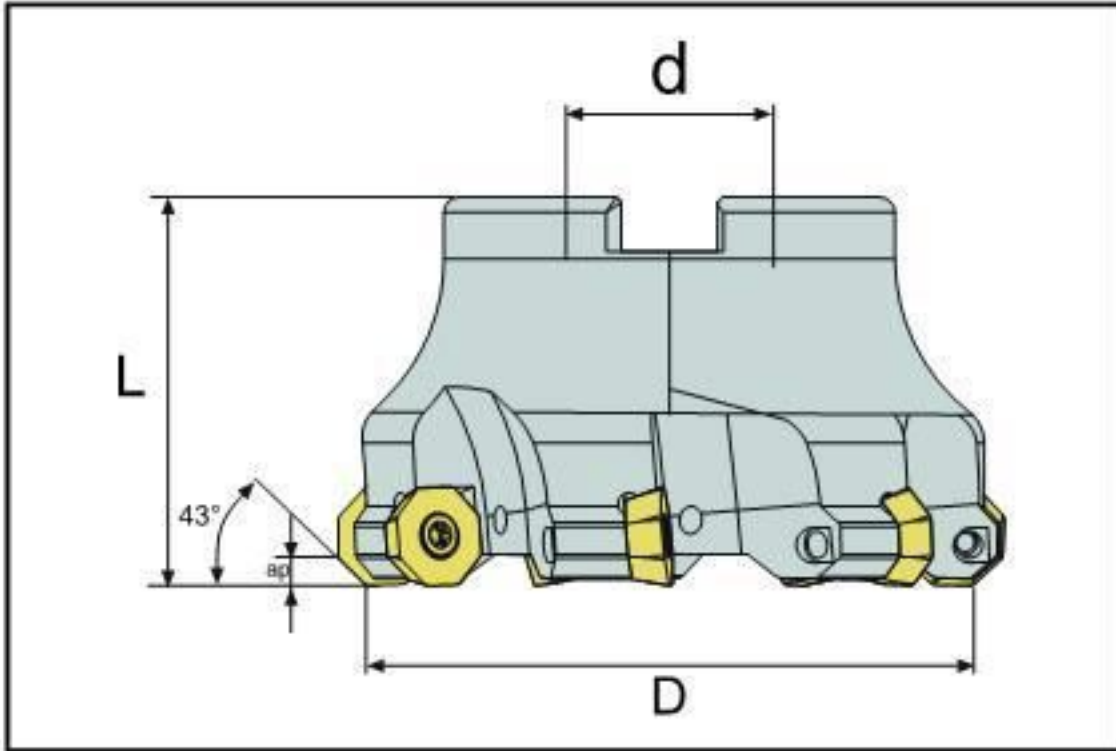

KOD CODE	ÖLÇÜLER DIMENSION (mm)					KESİCİ UÇ INSERT	YEDEK PARÇALAR SPARE PARTS	
	D	Z	d	L	ap		Sıkma Vidası Clamp Screw	Anahtar Torx Key
TK43° OD0504								
TK43C-OD0504-D40-A16-Z04-H	40	4	16	40	3,5	OD..0504..	SSV M3,5X9	T15
TK43C-OD0504-D50-A22-Z05-H	50	5	22	40	3,5			
TK43C-OD0504-D63-A22-Z06-H	63	6	22	40	3,5			
TK43C-OD0504-D80-A27-Z07-H	80	7	27	50	3,5			
TK43C-OD0504-D100-A32-Z08-H	100	8	32	50	3,5			

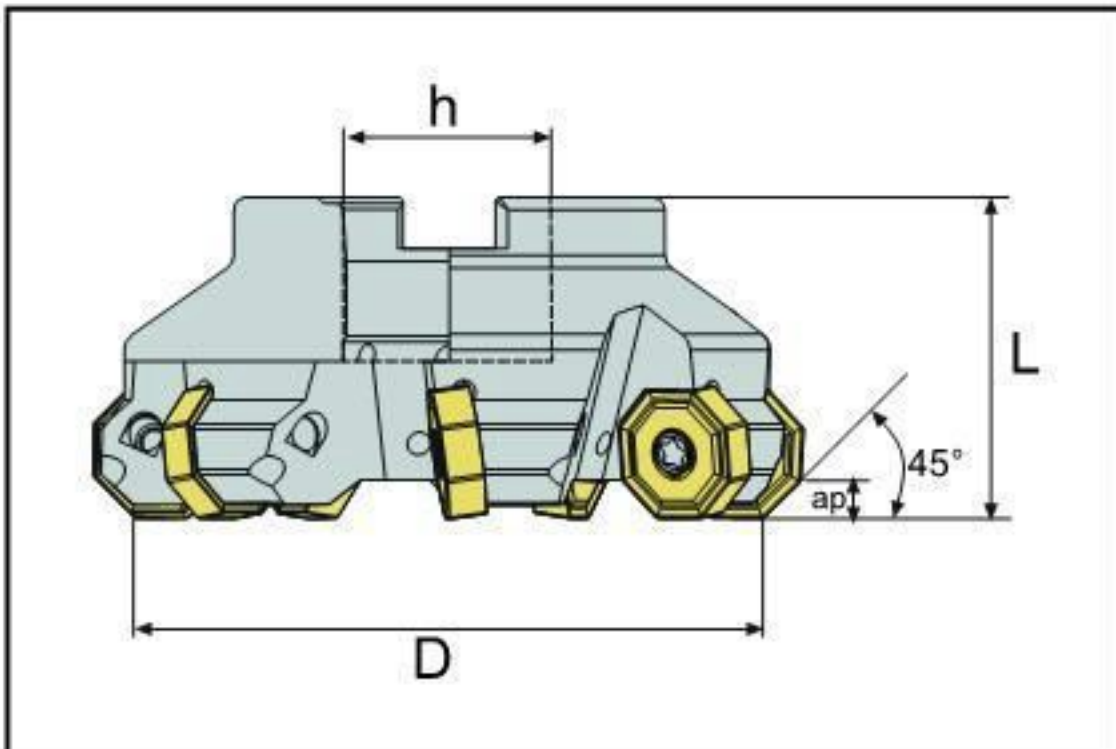

KOD CODE	ÖLÇÜLER DIMENSION (mm)					KESİCİ UÇ INSERT	YEDEK PARÇALAR SPARE PARTS	
	D	Z	d	L	ap		Sıkma Vidası Clamp Screw	Anahtar Torx Key
TK45° ON0806								
TK45C-ON08-D63-A22-Z05-H	63	5	22	40	4	ON.. 0806..	SSV M5X11	T20
TK45C-ON08-D80-A27-Z06-H	80	6	27	50	4			
TK45C-ON08-D100-A32-Z07-H	100	7	32	50	4			
TK45C-ON08-D125-B40-Z08-H	125	8	40	63	4			
TK45C-ON08-D160-C40-Z10-H	160	10	40	63	4			
TK45C-ON08-D200-C60-Z12-H	200	12	60	63	4			

YÜZEY FREZELER Face Milling Cutter

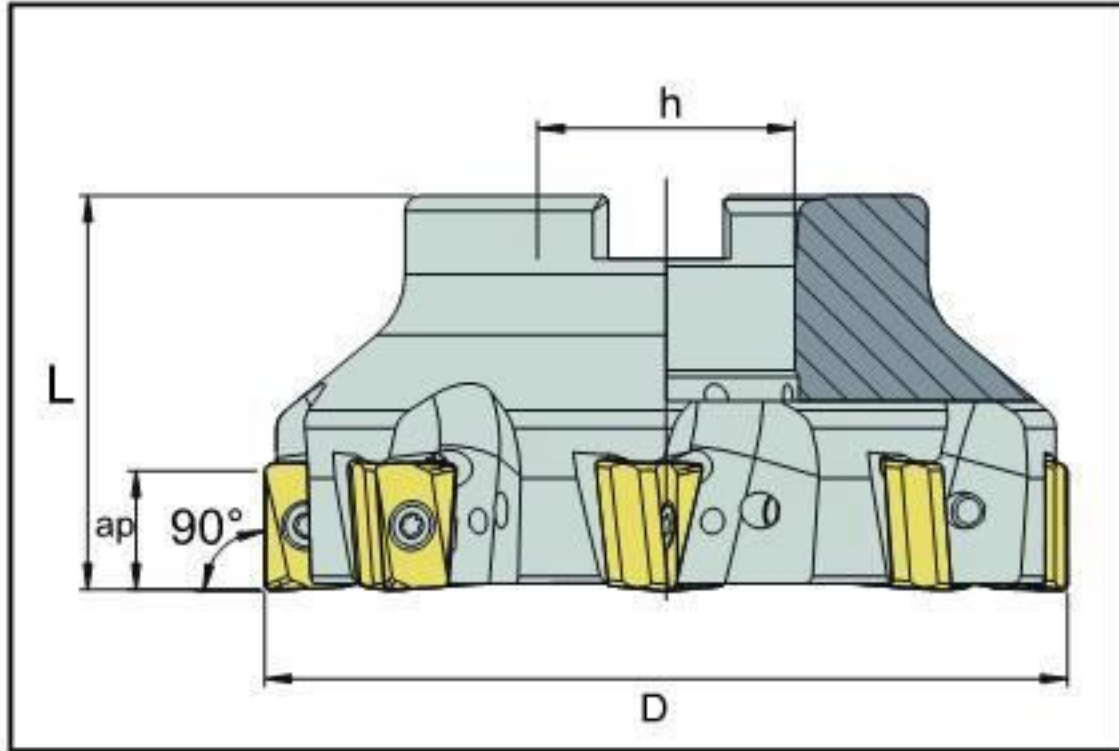

KOD CODE	ÖLÇÜLER DIMENSION (mm)					KESİCİ UÇ INSERT	YEDEK PARÇALAR SPARE PARTS	
	D	Z	d	L	ap		Sıkma Vidası Clamp Screw	Anahtar Torx Key
TK90° LN.X 1307						 LN.X..1307		
TK90C-LN13-D50-A22-Z05	50	5	22	40	15		SSV M4x9	T15
TK90C-LN13-D63-A22-Z06	63	6	22	40	15			
TK90C-LN13-D80-A32-Z07	80	7	32	50	15			
TK90C-LN13-D100-A32-Z08	100	8	32	50	15			
TK90C-LN13-D125-C40-Z10	125	10	40	63	15			

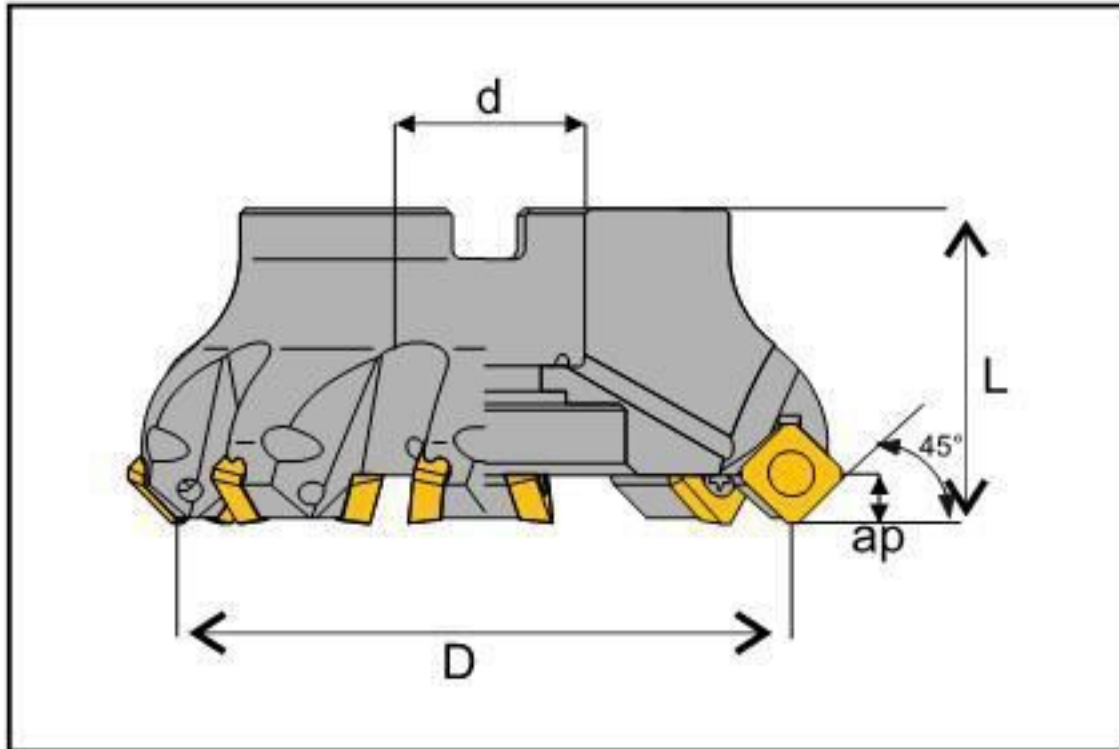

KOD CODE	ÖLÇÜLER DIMENSION (mm)					KESİCİ UÇ INSERT	YEDEK PARÇALAR SPARE PARTS	
	D	Z	d	L	ap		Sıkma Vidası Clamp Screw	Anahtar Torx Key
TK45° SD1204						 SD 1204..		
TK45C-SD12-D63-A22-Z05-H	63	5	22	40	6		SSV M3,5X9	T15
TK45C-SD12-D80-A27-Z06-H	80	6	27	50	6			
TK45C-SD12-D100-A32-Z07-H	100	7	32	50	6			
TK45C-SD12-D125-B40-Z07-H	125	11	40	63	6			

YÜZEY FREZELER Face Milling Cutter

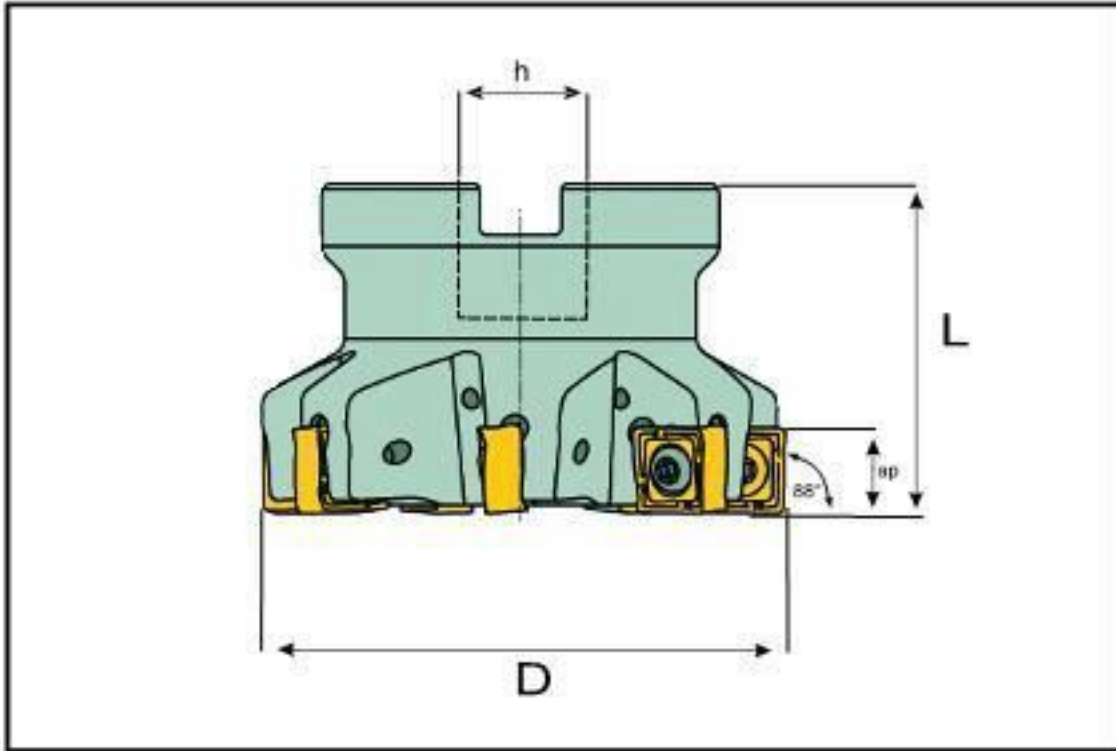

KOD CODE	ÖLÇÜLER DIMENSION (mm)					KESİCİ UÇ INSERT	YEDEK PARÇALAR SPARE PARTS			
	D	Z	d	L	ap		Sıkma Vidası Screw	Baskı Kepi Clamp	Kep Vidası Clamp Screw	Anahtar Torx Key
TK88° SN1206										
TK88C-SN12-D63-A22-Z07-H	63	6	22	40	10	SN1206..	SSV M4X11	BDTK	SSV M3,5X9	T15
TK88C-SN12-D80-A27-Z08-H	80	7	27	50	10					
TK88C-SN12-D100-A32-Z10-H	100	9	32	50	10					

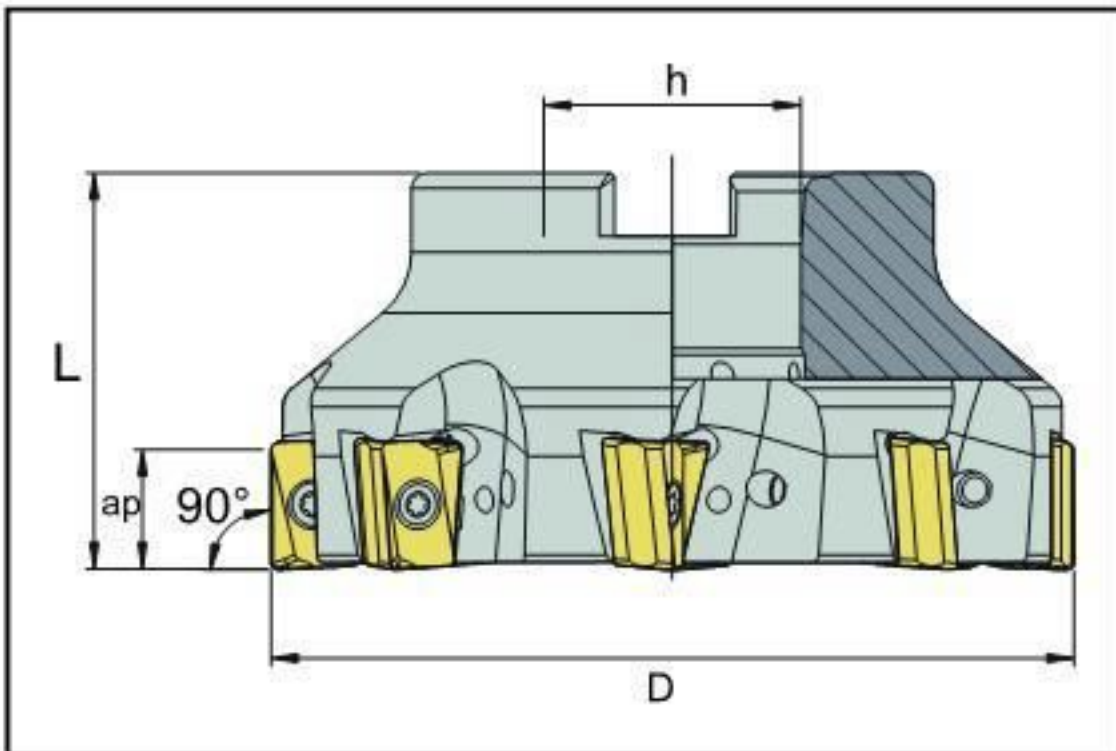

KOD CODE	ÖLÇÜLER DIMENSION (mm)					KESİCİ UÇ INSERT	YEDEK PARÇALAR SPARE PARTS	
	D	Z	d	L	ap		Sıkma Vidası Clamp Screw	Anahtar Torx Key
AN.X1607								
TK90C-AN16-D50-A22-Z04-H	50	4	22	40	15	AN.X 1607..	SSV M4X9	T15
TK90C-AN16-D63-A22-Z06-H	63	6	22	40	15			
TK90C-AN16-D80-A27-Z07-H	80	7	27	50	15			
TK90C-AN16-D100-A32-Z08-H	100	8	32	50	15			

YÜZEY FREZELER

Face Milling Cutter

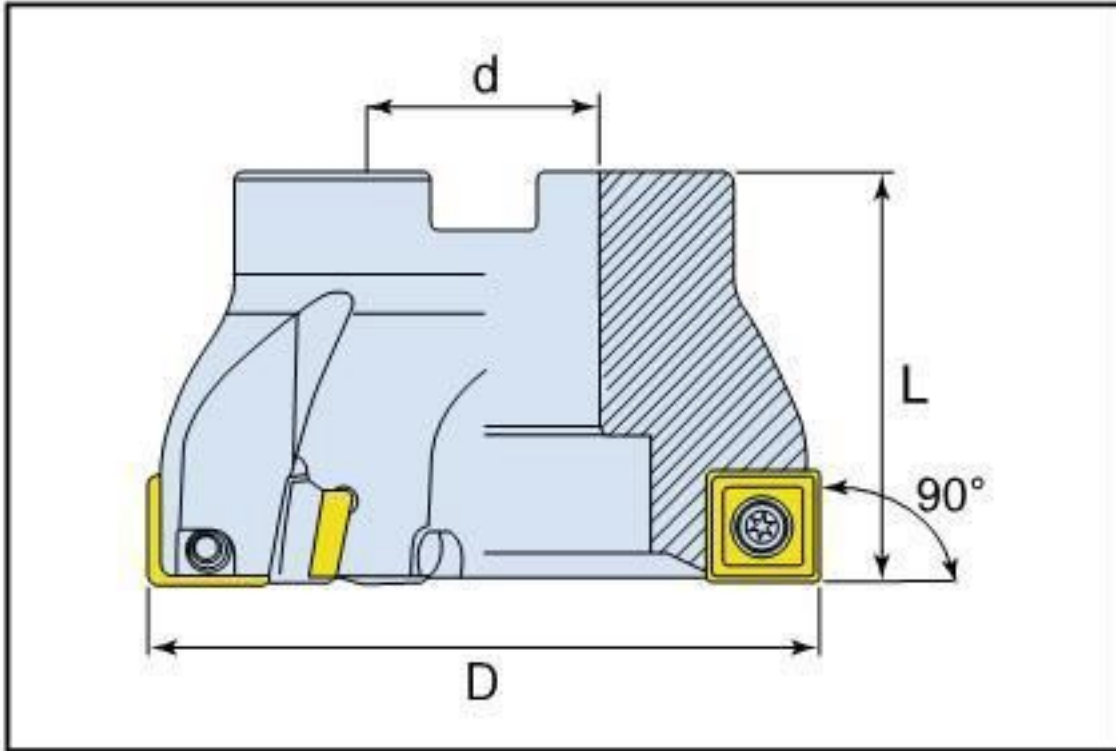

KOD CODE	ÖLÇÜLER DIMENSION (mm)					KEŞİCİ UÇ INSERT	YEDEK PARÇALAR SPARE PARTS	
	D	Z	d	L	ap		Sıkma Vidası Clamp Screw	Anahtar Torx Key
TK90° SD09M4-1305								
TK90C-SD09M4-D50-A22-Z05-H	50	5	22	40	9	SD 09M4	SSV M3,5x9	T15
TK90C-SD09M4-D63-A22-Z06-H	63	6	22	40	9			
TK90C-SD1305-D50-A22-Z04-H	50	4	22	40	13	SD 1305	SSV M5X11	T20
TK90C-SD1305-D63-A22-Z05-H	63	5	22	40	13			
TK90C-SD1305-D80-A27-Z06-H	80	6	27	50	13			
TK90C-SD1305-D100-A32-Z07-H	100	7	32	50	13			
TK90C-SD1305-D125-B40-Z08	125	8	40	63	13			
TK90C-SD1305-D160-C40-Z10	160	10	40	63	13			



YÜZEY FREZELER Face Milling Cutter

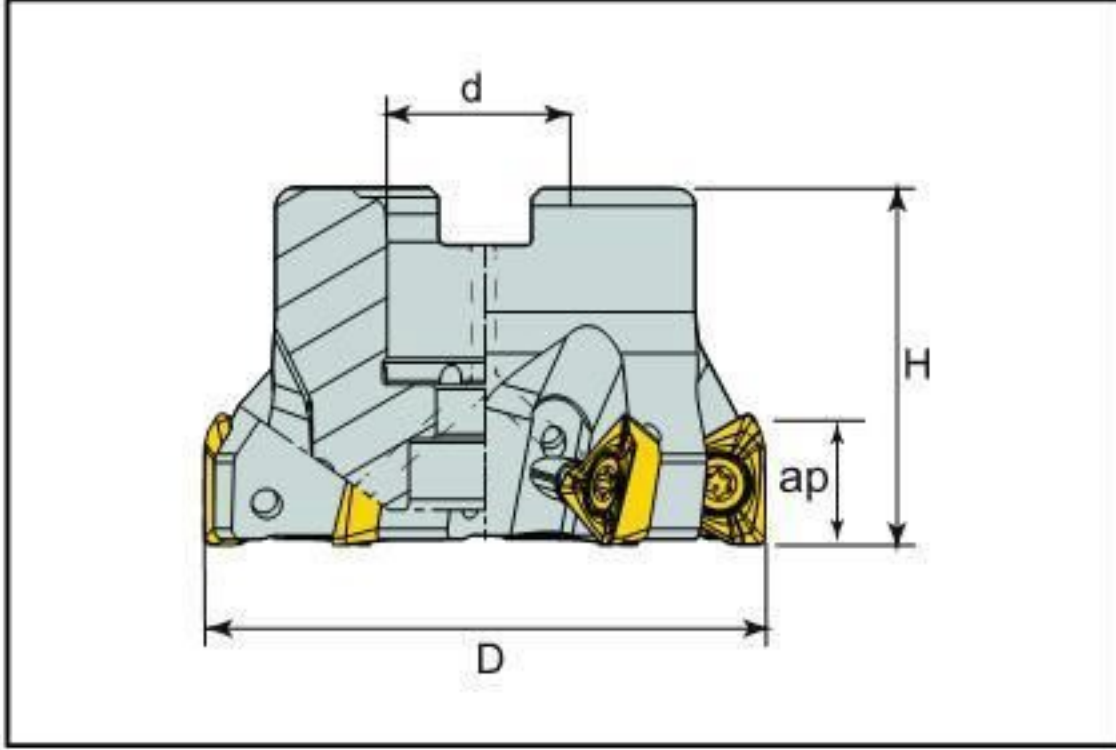

KOD CODE	ÖLÇÜLER DIMENSION (mm)					KESİCİ UÇ INSERT	YEDEK PARÇALAR SPARE PARTS	
	D	Z	d	L	ap		Sıkma Vidası Clamp Screw	Anahtar Torx Key
TK90° TPKT2205	D	Z	d	L	ap	 TPKT 2205	 SSV M4,5X12	 T20
TK90C-TP22-D63-A22-Z04	63	4	22	40	18			
TK90C-TP22-D80-A27-Z06	80	6	27	50	18			
TK90C-TP22-D100-A32-Z07	100	7	32	50	18			
TK90C-TP22-D125-B40-Z08	125	8	40	63	18			
TK90C-TP22-D160-C40-Z09	160	9	40	63	18			

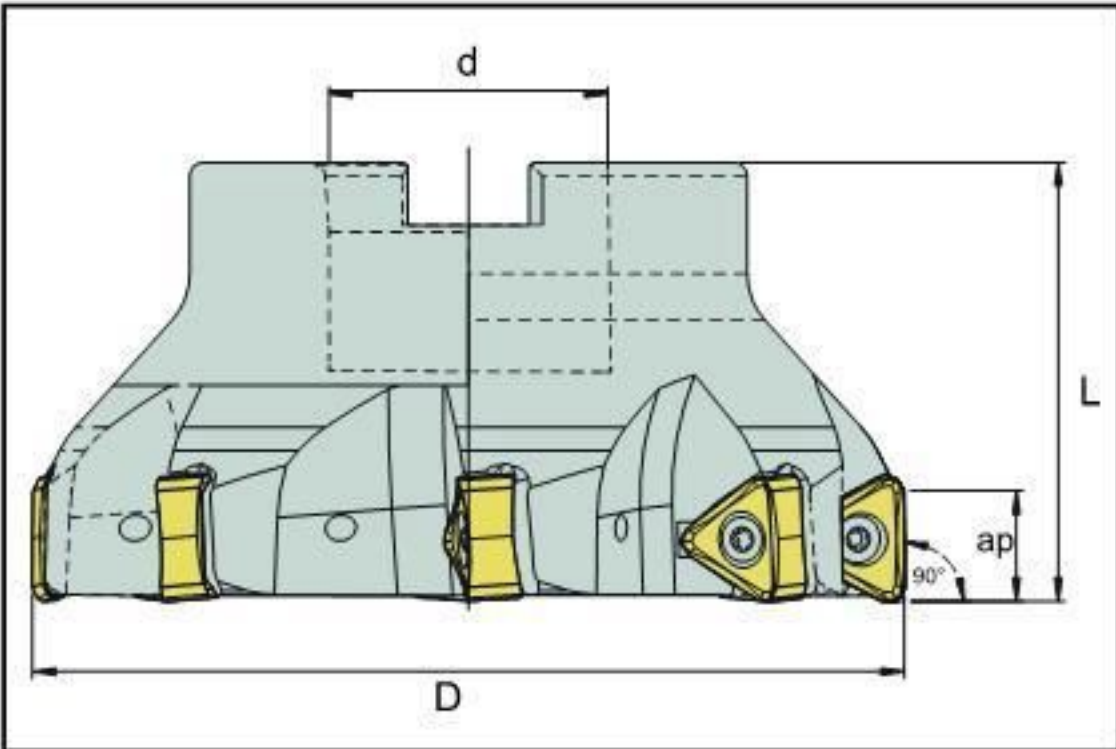



KOD CODE	ÖLÇÜLER DIMENSION (mm)					KESİCİ UÇ INSERT	YEDEK PARÇALAR SPARE PARTS	
	D	Z	d	L	ap		Sıkma Vidası Clamp Screw	Anahtar Torx Key
TK90° TN.X2207	D	Z	d	L	ap	 TN.X 2207	 SSV M4,5X12	 T20
TK90C-TN22-D63-A22-Z04-H	63	4	22	40	15			
TK90C-TN22-D80-A27-Z06-H	80	5	27	50	15			
TK90C-TN22-D100-A32-Z07	100	6	32	50	15			
TK90C-TN22-D125-B40-Z08	125	8	40	63	15			

YÜZEY FREZELER

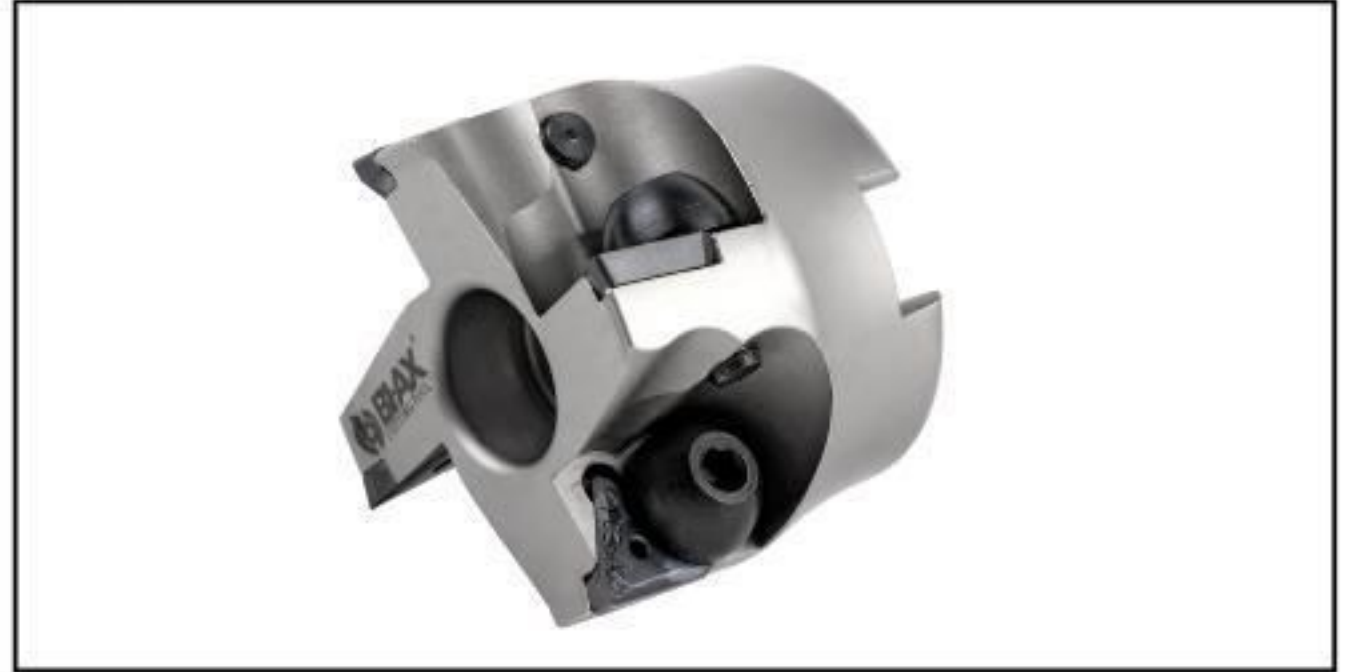
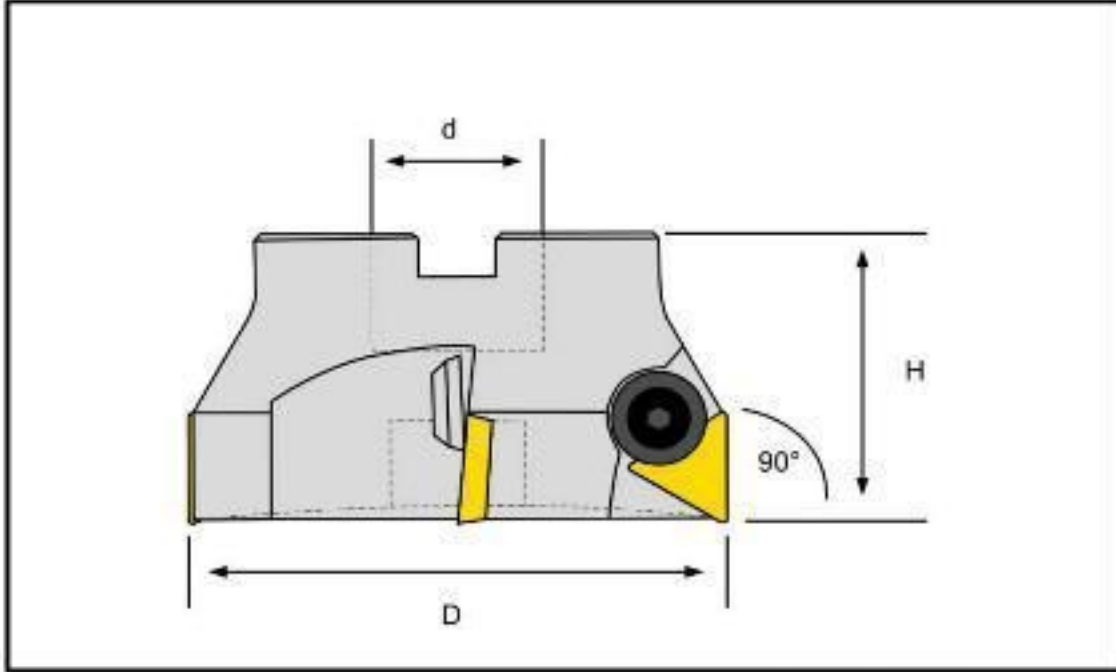
Face Milling Cutter



KOD CODE	ÖLÇÜLER DIMENSION (mm)					KESİCİ UÇ INSERT	YEDEK PARÇALAR SPARE PARTS	
	D	Z	d	L	ap		Sıkma Vidası Clamp Screw	Anahtar Allen Key
TPKN2205								
TK90C-TP22-D63-A22-Z04	63	5	22	45	18	TPKN 2205	TPBV 8X10	AA5
TK90C-TP22-D80-A27-Z06	80	6	27	50	18			
TK90C-TP22-D100-A32-Z07	100	7	32	50	18			
TK90C-TP22-D125-B40-Z08	125	8	40	63	18			
TK90C-TP16-D50-A22-Z04	50	4	22	40	12	TPKN 1603	TPBV 6X10	AA4
TK90C-TP16-D63-A22-Z04	63	6	22	45	12			
TK90C-TP16-D80-A27-Z06	80	7	27	50	12			
TK90C-TP16-D100-A32-Z07	100	8	32	50	12			
TK90C-TP16-D125-B40-Z08	125	10	40	63	12			

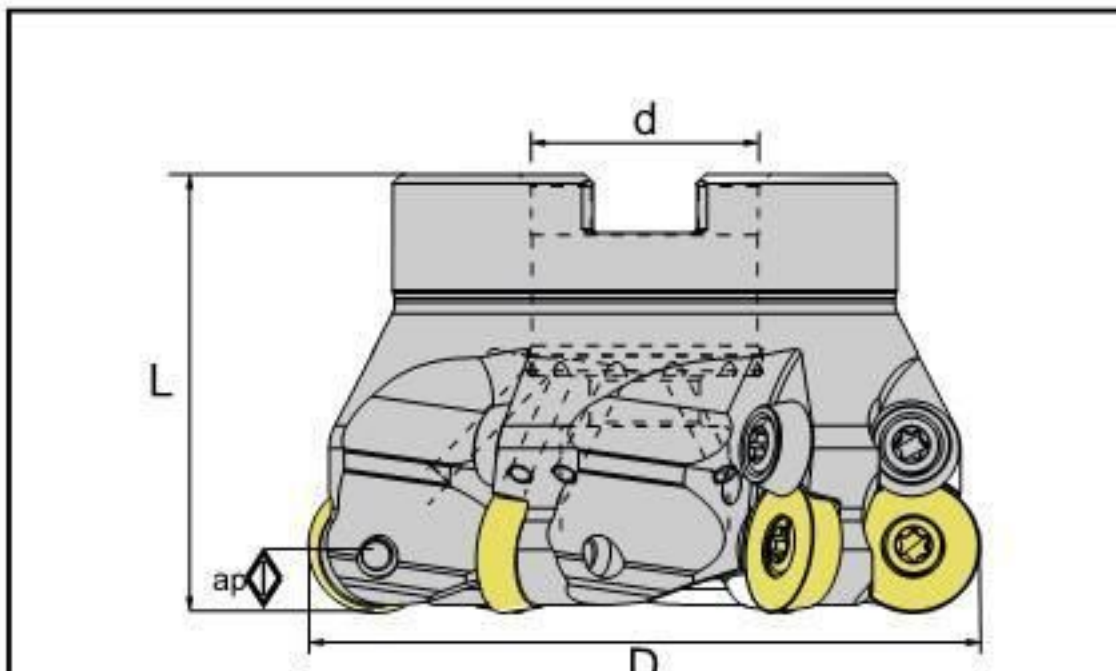

KOD CODE	ÖLÇÜLER DIMENSION (mm)					KESİCİ UÇ INSERT	YEDEK PARÇALAR SPARE PARTS			
	D	Z	d	L	ap		Sıkma Vidası Screw	Baskı Kepi Clamp	Kep Vidası Clamp Screw	Anahtar Torx Key
RDMT 1003										
TK-RD1003-D40-A16-Z04-H	40	4	16	40	5	RD.. 1003	RD... 12T3	RTBP-1	SSV M3,5x9	T15
TK-RD1003-D50-A22-Z05-H	50	5	22	50	5					
TK-RD1003-D63-A22-Z06-H	63	6	22	50	5					
TK-RD1003-D80-A27-Z07-H	80	7	27	50	5					
TK-RD12T3-D40-A16-Z04-H	40	4	16	40	6	RD... 12T3	SSV M3,5x9	RTBP-1	SSV M3,5x9	T15
TK-RD12T3-D50-A22-Z05-H	50	5	22	50	6					
TK-RD12T3-D63-A22-Z06-H	63	6	22	50	6					
TK-RD12T3-D80-A27-Z07-H	80	7	27	50	6					
TK-RD12T3-D100-A32-Z08-H	100	8	32	50	6					
TK-RD12T3-D125-B40-Z09	125	9	40	63	6					

DEĞİŞKEN UÇLU MATKAPLAR

U - DRILL



DEĞİŞKEN UÇLU MATKAPLAR

U-Drill

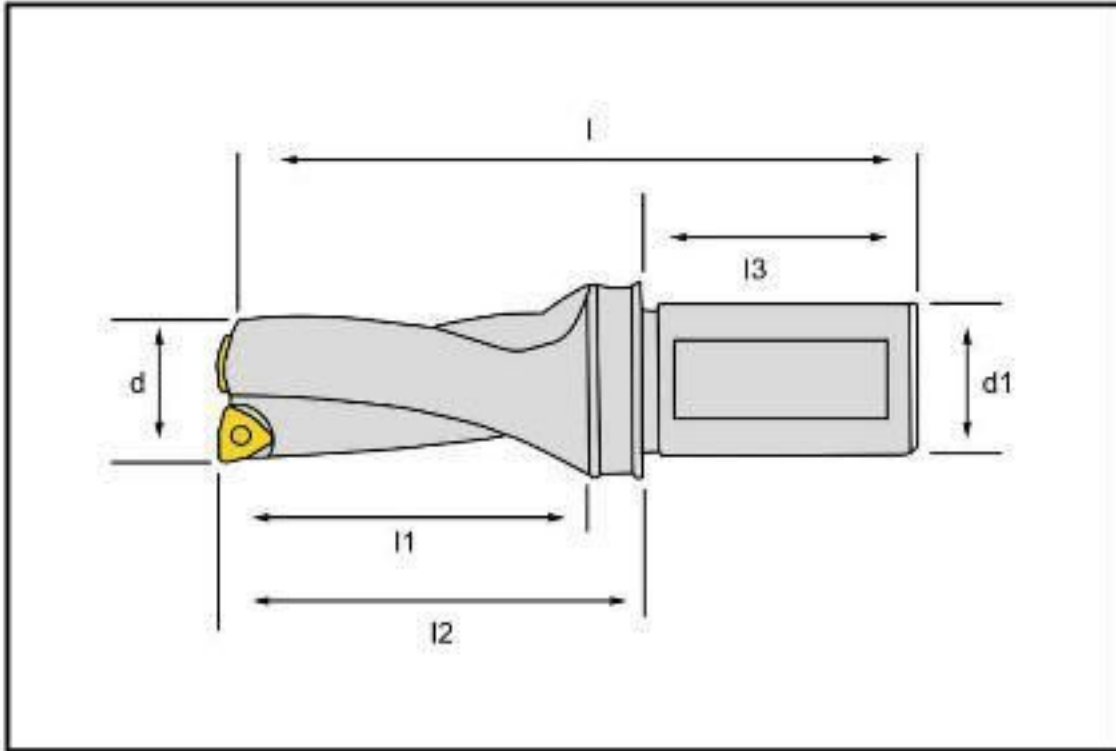



KOD CODE	ÖLÇÜLER DIMENSION (mm)							KESİCİ UÇ INSERT	YEDEK PARÇALAR SPARE PARTS	
	D	d1	d2	L	L1	L2	Ls		Sıkma Vidası Clamp Screw	Anahtar Torx Key
WCMX D2 U-DRILL										
SDUM 16xD2	16	25	34	108	32	52	56	WCM. 030208	SSV M2,5x7,5	T08
SDUM 16,5xD2	16,5	25	34	110	33	54	56			
SDUM 17xD2	17	25	34	110	34	54	56			
SDUM 17,5xD2	17,5	25	34	113	35	57	56			
SDUM 18 xD2	18	25	34	113	36	57	56			
SDUM 18,5 xD2	18,5	25	34	115	37	59	56			
SDUM 19 xD2	19	25	34	115	38	59	56			
SDUM 19,5 xD2	19,5	25	34	119	39	63	56			
SDUM 20 xD2	20	25	34	119	40	63	56			
SDUM 20,5 xD2	20,5	25	34	121	41	65	56			
SDUM 21 xD2	21	25	34	121	42	65	56	WCM 040208	T08	
SDUM 21,5 xD2	21,5	25	34	123	43	67	56			
SDUM 22 xD2	22	25	34	123	44	67	56			
SDUM 22,5 xD2	22,5	25	34	127	45	71	56			
SDUM 23 xD2	23	25	34	127	46	71	56			
SDUM 23,5 xD2	23,5	25	34	130	47	74	56			
SDUM 24 xD2	24	25	44	130	48	74	56			
SDUM 24,5 xD2	24,5	25	44	133	49	77	56			
SDUM 25 xD2	25	25	44	133	50	77	56			
SDUM 25,5 xD2	25,5	25	44	135	51	79	56			
SDUM 26 xD2	26	25	44	135	52	79	56	WCM 050308	SSV M3,5x9	
SDUM 26,5 xD2	26,5	25	44	137	53	81	56			
SDUM 27 xD2	27	25	44	137	54	81	56			
SDUM 27,5 xD2	27,5	25	44	140	55	84	56			
SDUM 28 xD2	28	25	44	140	56	84	56			
SDUM 28,5 xD2	28,5	25	44	142	57	86	56			
SDUM 29 xD2	29	25	44	142	58	86	56			
SDUM 29,5 xD2	29,5	25	44	151	59	91	56			

DEĞİŞKEN UÇLU MATKAPLAR

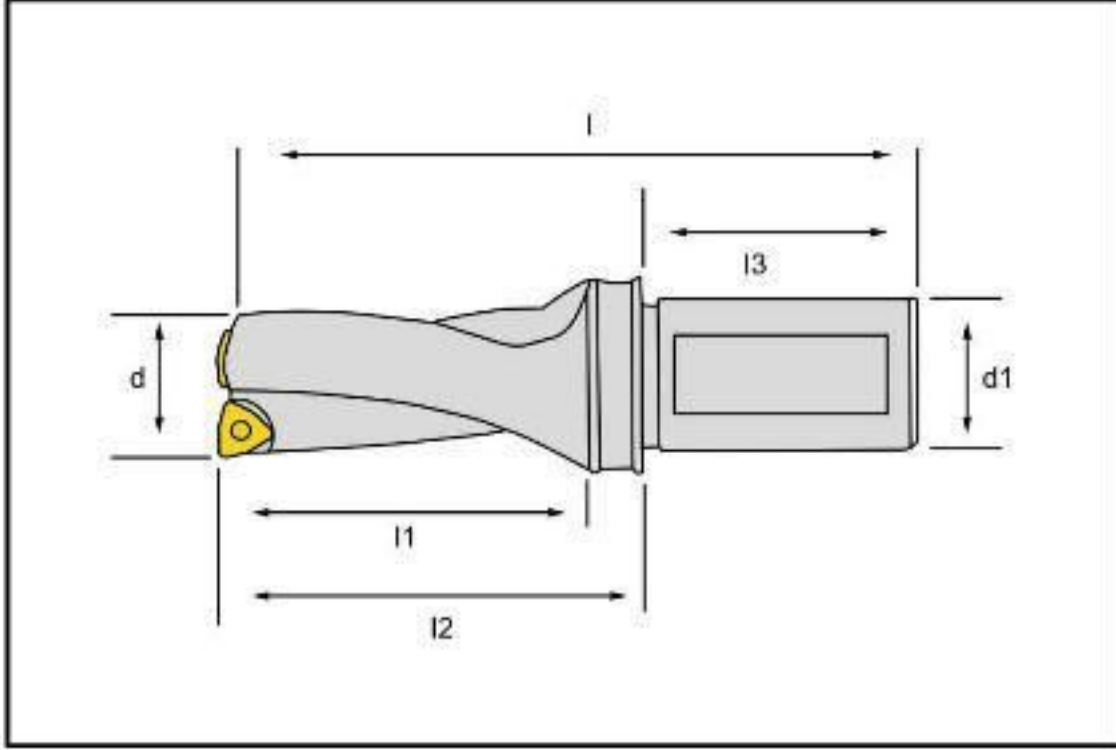
U-Drill



KOD CODE	ÖLÇÜLER DIMENSION (mm)							KEŞİCİ UÇ INSERT	YEDEK PARÇALAR SPARE PARTS	
	D	d1	d2	L	L1	L2	Ls		Sıkma Vidası Clamp Screw	Anahtar Torx Key
WCMX D2 U-DRILL										
SDUM 30 xD2	30	32	44	151	60	91	60	WCM 06T308	SSV M3,5x9	T15
SDUM 31 xD2	31	32	44	154	62	94	60			
SDUM 32 xD2	32	32	44	156	64	96	60			
SDUM 33 xD2	33	32	44	159	66	99	60			
SDUM 34 xD2	34	32	44	161	68	101	60			
SDUM 35 xD2	35	32	44	164	70	104	60			
SDUM 36 xD2	36	32	44	167	72	107	60			
SDUM 37 xD2	37	32	44	170	74	110	60			
SDUM 38 xD2	38	32	44	173	76	113	60			
SDUM 39 xD2	39	32	44	175	78	115	60			
SDUM 40 xD2	40	32	44	178	80	118	60			
SDUM 41 xD2	41	32	44	181	82	121	60			
SDUM 42 xD2	42	32	44	183	84	123	60			
SDUM 43 xD2	43	32	44	186	86	126	60			
SDUM 44 xD2	44	32	44	188	88	128	60			
SDUM 45 xD2	45	40	54	202	90	132	70	WCM 080412	SSV M4x11	T15
SDUM 46 xD2	46	40	54	205	92	135	70			
SDUM 47 xD2	47	40	54	207	94	137	70			
SDUM 48 xD2	48	40	54	210	96	140	70			
SDUM 49 xD2	49	40	54	212	98	142	70			
SDUM 50 xD2	50	40	54	215	100	145	70			
SDUM 51 xD2	51	40	60	217	102	147	70			
SDUM 52 xD2	52	40	60	220	104	150	70			
SDUM 53 xD2	53	40	60	222	106	152	70			
SDUM 54 xD2	54	40	60	225	108	155	70			
SDUM 55 xD2	55	40	60	227	110	157	70			
SDUM 56 xD2	56	40	60	230	112	160	70			
SDUM 57 xD2	57	40	60	232	114	162	70			
SDUM 58 xD2	58	40	60	235	116	165	70			
SDUM 59 xD2	59	40	60	237	118	167	70			
SDUM 60 xD2	60	40	60	240	120	170	70			

DEĞİŞKEN UÇLU MATKAPLAR

U-Drill

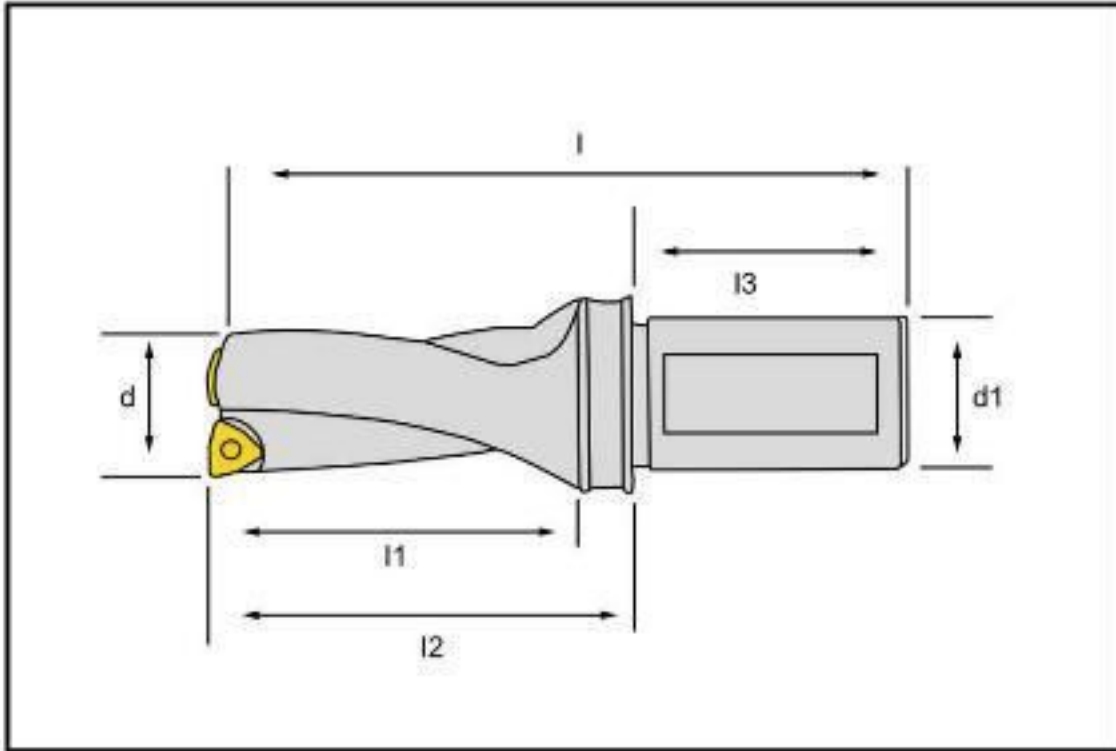



KOD CODE	ÖLÇÜLER DIMENSION (mm)							KESİCİ UÇ INSERT	YEDEK PARÇALAR SPARE PARTS	
	D	d1	d2	L	L1	L2	Ls		Sıkma Vidası Clamp Screw	Anahtar Torx Key
WCMX D3 U-DRILL										
SDUM 16 xD3	16	25	34	108	48	68	56	WCM. 030208	SSV M2,5x7,5	T08
SDUM 16,5 xD3	16,5	25	34	110	49,5	71	56			
SDUM 17 xD3	17	25	34	110	51	71	56			
SDUM 17,5 xD3	17,5	25	34	113	52,5	75	56			
SDUM 18 xD3	18	25	34	113	54	75	56			
SDUM 18,5 xD3	18,5	25	34	115	55,5	78	56			
SDUM 19 xD3	19	25	34	115	57	78	56			
SDUM 19,5 xD3	19,5	25	34	119	58,5	83	56			
SDUM 20 xD3	20	25	34	119	60	83	56			
SDUM 20,5 xD3	20,5	25	34	121	61,5	86	56			
SDUM 21 xD3	21	25	34	121	63	86	56			
SDUM 21,5 xD3	21,5	25	34	123	64,5	89	56			
SDUM 22 xD3	22	25	34	123	66	89	56			
SDUM 22,5 xD3	22,5	25	34	127	67,5	94	56			
SDUM 23 xD3	23	25	34	127	69	94	56			
SDUM 23,5 xD3	23,5	25	34	130	70,5	98	56			
SDUM 24 xD3	24	25	44	130	72	98	56			
SDUM 24,5 xD3	24,5	25	44	133	73,5	102	56			
SDUM 25 xD3	25	25	44	133	75	102	56	WCM 050308	SSV M3,5x9	
SDUM 25,5 xD3	25,5	25	44	135	76,5	105	56			
SDUM 26 xD3	26	25	44	135	78	105	56			
SDUM 26,5 xD3	26,5	25	44	137	79,5	108	56			
SDUM 27 xD3	27	25	44	137	81	108	56			
SDUM 27,5 xD3	27,5	25	44	140	82,5	112	56			
SDUM 28 xD3	28	25	44	140	84	112	56			
SDUM 28,5 xD3	28,5	25	44	142	85,5	115	56			
SDUM 29 xD3	29	25	44	142	87	115	56			
SDUM 29,5 xD3	29,5	25	44	151	88,5	121	56			

DEĞİŞKEN UÇLU MATKAPLAR

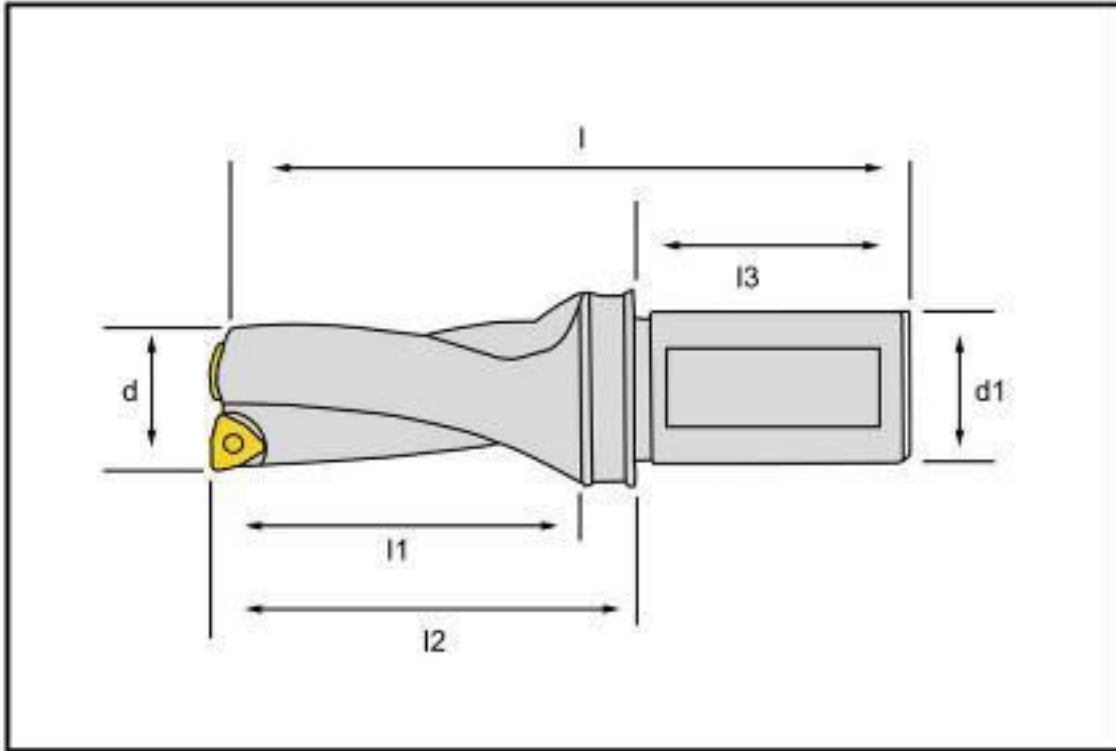
U-Drill





KOD CODE	ÖLÇÜLER DIMENSION (mm)							KEŞİCİ UÇ INSERT	YEDEK PARÇALAR SPARE PARTS	
	D	d1	d2	L	L1	L2	Ls		Sıkma Vidası Clamp Screw	Anahtar Torx Key
WCMX D3 U-DRILL										
SDUM 30 xD3	30	32	44	151	90	121	60	WCM 06T308	SSV M3,5x9	T15
SDUM 31 xD3	31	32	44	154	93	125	60			
SDUM 32 xD3	32	32	44	156	96	128	60			
SDUM 33 xD3	33	32	44	159	99	132	60			
SDUM 34 xD3	34	32	44	161	102	135	60			
SDUM 35 xD3	35	32	44	164	105	139	60			
SDUM 36 xD3	36	32	44	167	108	143	60			
SDUM 37 xD3	37	32	44	170	111	147	60			
SDUM 38 xD3	38	32	44	173	114	151	60			
SDUM 39 xD3	39	32	44	175	117	154	60			
SDUM 40 xD3	40	32	44	178	120	158	60			
SDUM 41 xD3	41	32	44	181	123	162	60			
SDUM 42 xD3	42	32	44	183	126	165	60			
SDUM 43 xD3	43	32	44	186	129	169	60			
SDUM 44 xD3	44	32	44	188	132	172	60			
SDUM 45 xD3	45	40	54	202	135	177	70	WCM 080412	SSV M4x11	T15
SDUM 46 xD3	46	40	54	205	138	181	70			
SDUM 47 xD3	47	40	54	207	141	184	70			
SDUM 48 xD3	48	40	54	210	144	188	70			
SDUM 49 xD3	49	40	54	212	147	191	70			
SDUM 50 xD3	50	40	54	215	150	195	70			
SDUM 51 xD3	51	40	60	217	153	198	70			
SDUM 52 xD3	52	40	60	220	156	201	70			
SDUM 53 xD3	53	40	60	222	159	204	70			
SDUM 54 xD3	54	40	60	225	162	207	70			
SDUM 55 xD3	55	40	60	227	165	210	70			
SDUM 56 xD3	56	40	60	230	168	213	70			
SDUM 57 xD3	57	40	60	232	171	216	70			
SDUM 58 xD3	58	40	60	235	174	219	70			
SDUM 59 xD3	59	40	60	237	177	222	70			
SDUM 60 xD3	60	40	60	240	180	225	70			

DEĞİŞKEN UÇLU MATKAPLAR

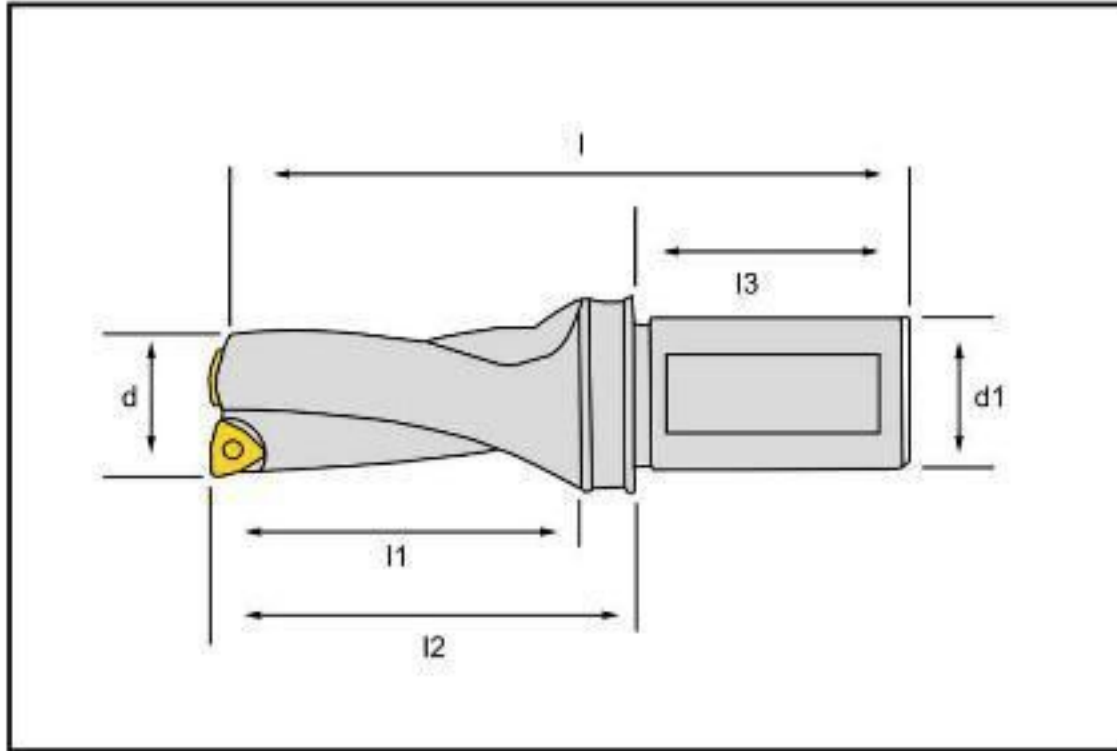
U-Drill



KOD CODE	ÖLÇÜLER DIMENSION (mm)							KESİCİ UÇ INSERT	YEDEK PARÇALAR SPARE PARTS	
	D	d1	d2	L	L1	L2	Ls		Sıkma Vidası Clamp Screw	Anahtar Torx Key
WCMX D4 U-DRILL										
SDUM 16xD4	16	25	34	140	64	84	56	WCM 06T308	SSV M2,5x7,5	T08
SDUM 17xD4	17	25	34	144	68	88	56			
SDUM 18xD4	18	25	34	149	72	93	56			
SDUM 19xD4	19	25	34	153	76	97	56			
SDUM 20xD4	20	25	34	159	80	103	56	WCM 040208	SSV M2,5x7,5	T08
SDUM 21xD4	21	25	34	163	84	107	56			
SDUM 22xD4	22	25	34	167	88	111	56			
SDUM 23xD4	23	25	34	173	92	117	56			
SDUM 24xD4	24	25	34	178	96	122	56	WCM 050308	SSV M3x9	T08
SDUM 25xD4	25	25	34	183	100	127	56			
SDUM 26xD4	26	25	34	187	104	131	56			
SDUM 27xD4	27	25	34	191	108	135	56			
SDUM 28xD4	28	25	34	196	112	140	56	WCM 06T308	SSV M3,5x9	T15
SDUM 29xD4	29	25	34	200	116	144	56			
SDUM 30xD4	30	32	44	211	120	151	60			
SDUM 31xD4	31	32	44	216	124	156	60			
SDUM 32xD4	32	32	44	220	128	160	60	WCM 080412	SSV M4x11	T15
SDUM 33xD4	33	32	44	225	132	165	60			
SDUM 34xD4	34	32	44	229	136	169	60			
SDUM 35xD4	35	32	44	234	140	174	60			
SDUM 36xD4	36	32	44	239	144	179	60	WCM 06T308	SSV M3,5x9	T15
SDUM 37xD4	37	32	44	244	148	184	60			
SDUM 38xD4	38	32	44	249	152	189	60			
SDUM 39xD4	39	32	44	253	156	193	60			
SDUM 40xD4	40	32	44	258	160	198	60	WCM 080412	SSV M4x11	T15
SDUM 41xD4	41	32	44	263	164	203	60			
SDUM 42xD4	42	32	44	267	168	207	60			
SDUM 43xD4	43	32	44	272	172	212	60			
SDUM 44xD4	44	32	44	276	176	216	60	WCM 080412	SSV M4x11	T15
SDUM 45xD4	45	32	54	292	180	222	70			
SDUM 46xD4	46	32	54	297	184	227	70			
SDUM 47xD4	47	32	54	301	188	231	70			
SDUM 48xD4	48	32	54	306	192	236	70	WCM 080412	SSV M4x11	T15
SDUM 49xD4	49	32	54	310	196	240	70			
SDUM 50xD4	50	32	54	315	200	245	70			

DEĞİŞKEN UÇLU MATKAPLAR

U-Drill

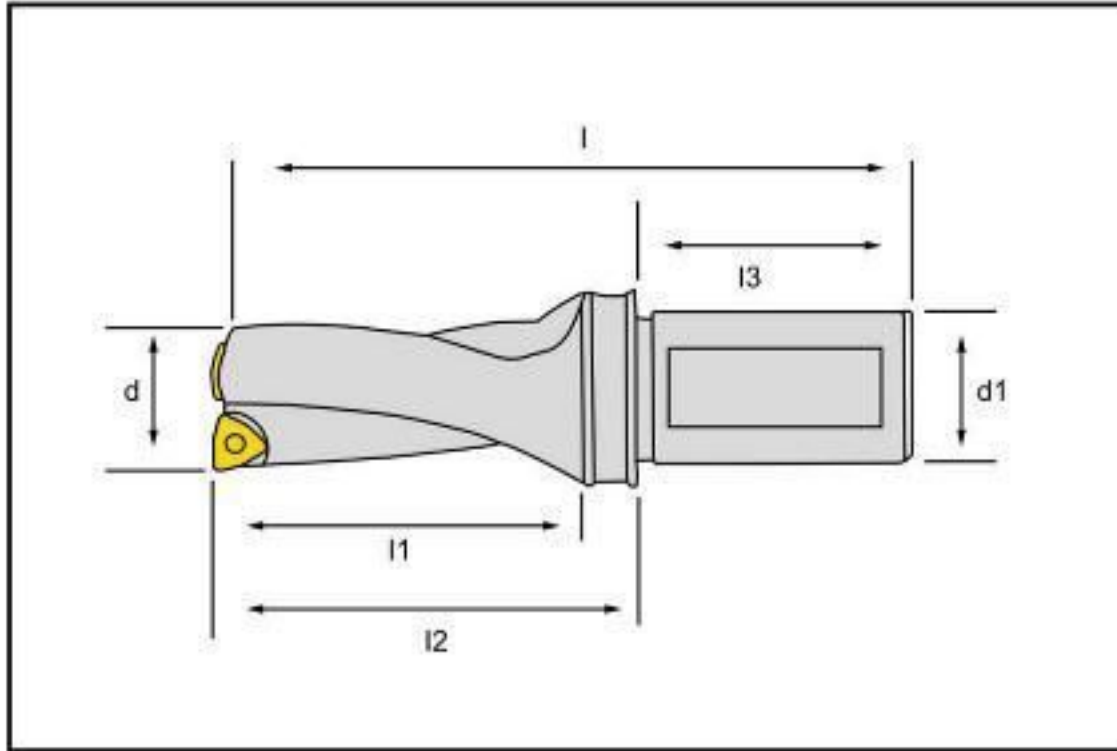





KOD CODE	ÖLÇÜLER DIMENSION (mm)							KEŞİTÇİ UÇ INSERT	YEDEK PARÇALAR SPARE PARTS	
	D	d1	d2	L	L1	L2	Ls		Sıkma Vidası Clamp Screw	Anahtar Torx Key
WCMX D5 U-DRILL										
SDUM 16xD5	16	25	34	150	80	100	56	WCM 06T308	SSV M2,5x7,5	T08
SDUM 17xD5	17	25	34	161	85	105	56			
SDUM 18xD5	18	25	34	167	90	111	56			
SDUM 19xD5	19	25	34	172	95	116	56			
SDUM 20xD5	20	25	34	179	100	123	56	WCM 040208	SSV M2,5x7,5	T08
SDUM 21xD5	21	25	34	184	105	128	56			
SDUM 22xD5	22	25	34	189	110	133	56			
SDUM 23xD5	23	25	34	193	115	137	56			
SDUM 24xD5	24	25	34	198	120	142	56	WCM 050308	SSV M3x9	T08
SDUM 25xD5	25	25	34	203	125	147	56			
SDUM 26xD5	26	25	34	207	130	151	56			
SDUM 27xD5	27	25	34	211	135	156	56			
SDUM 28xD5	28	25	34	216	140	162	56	WCM 06T308	SSV M3,5x9	T15
SDUM 29xD5	29	25	34	220	145	166	56			
SDUM 30xD5	30	32	44	224	150	171	60			

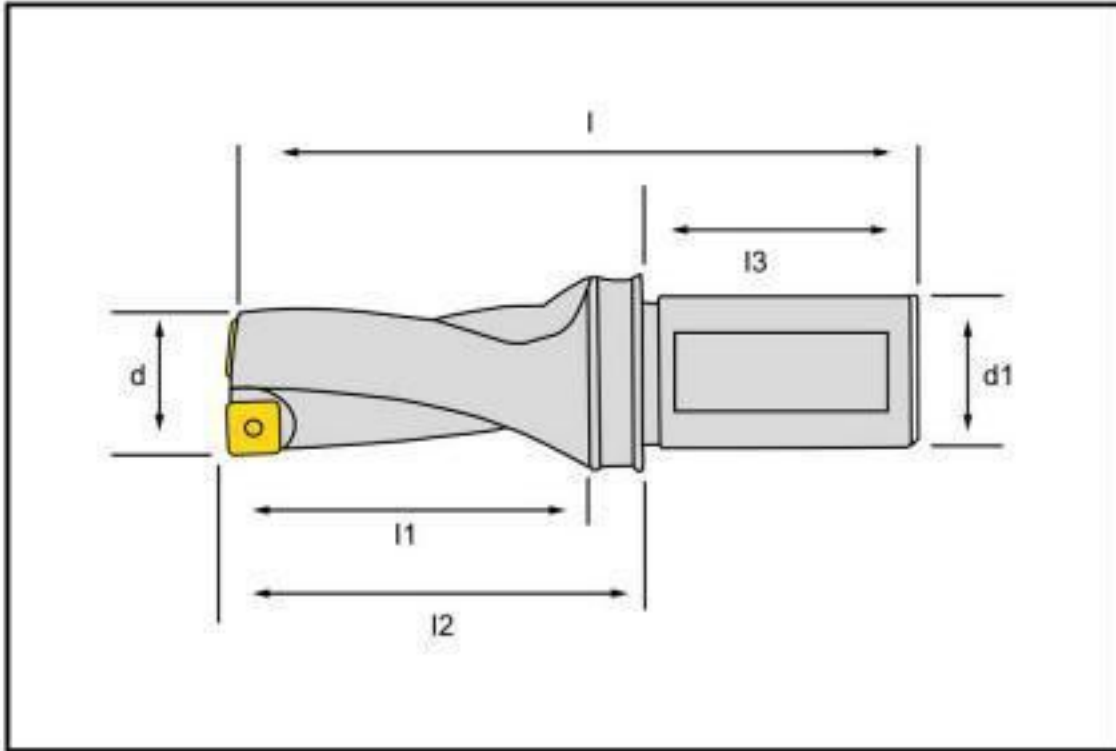

DEĞİŞKEN UÇLU MATKAPLAR

U-Drill





KOD CODE	ÖLÇÜLER DIMENSION (mm)							KEŞİCİ UÇ INSERT	YEDEK PARÇALAR SPARE PARTS	
	D	d1	d2	L	L1	L2	Ls		Sıkma Vidası Clamp Screw	Anahtar Torx Key
SPMT D2 U-DRILL										
SDUM 13 xD2	13	20	25	94	26	44	50	SPMT 050203	SSV M2x6	T06
SDUM 13,5 xD2	13,5	20	25	96	27	46	50			
SDUM 14 xD2	14	20	25	96	28	46	50			
SDUM 14,5 xD2	14,5	20	25	99	29	49	50			
SDUM 15 xD2	15	20	25	99	30	49	50			
SDUM 15,5 xD2	15,5	20	25	102	31	52	50			
SDUM 16 xD2	16	25	34	108	32	52	56	SPMT 060204	M2,2x6	T07
SDUM 16,5 xD2	16,5	25	34	110	33	54	56			
SDUM 17 xD2	17	25	34	110	34	54	56			
SDUM 17,5 xD2	17,5	25	34	113	35	57	56			
SDUM 18 xD2	18	25	34	113	36	57	56			
SDUM 18,5 xD2	18,5	25	34	115	37	59	56			
SDUM 19 xD2	19	25	34	115	38	59	56			
SDUM 19,5 xD2	19,5	25	34	119	39	63	56			
SDUM 20 xD2	20	25	34	119	40	63	56			
SDUM 20,5 xD2	20,5	25	34	121	41	65	56			
SDUM 21 xD2	21	25	34	121	42	65	56			
SDUM 21,5 xD2	21,5	25	34	123	43	67	56			
SDUM 22 xD2	22	25	34	123	44	67	56	SPMT 070204	SSV M2,5x7,5	T08
SDUM 22,5 xD2	22,5	25	34	127	45	71	56			
SDUM 23 xD2	23	25	34	127	46	71	56			
SDUM 23,5 xD2	23,5	25	34	130	47	74	56			
SDUM 24 xD2	24	25	34	130	48	74	56			
SDUM 24,5 xD2	24,5	25	34	133	49	77	56			
SDUM 25 xD2	25	25	34	133	50	77	56			

DEĞİŞKEN UÇLU MATKAPLAR

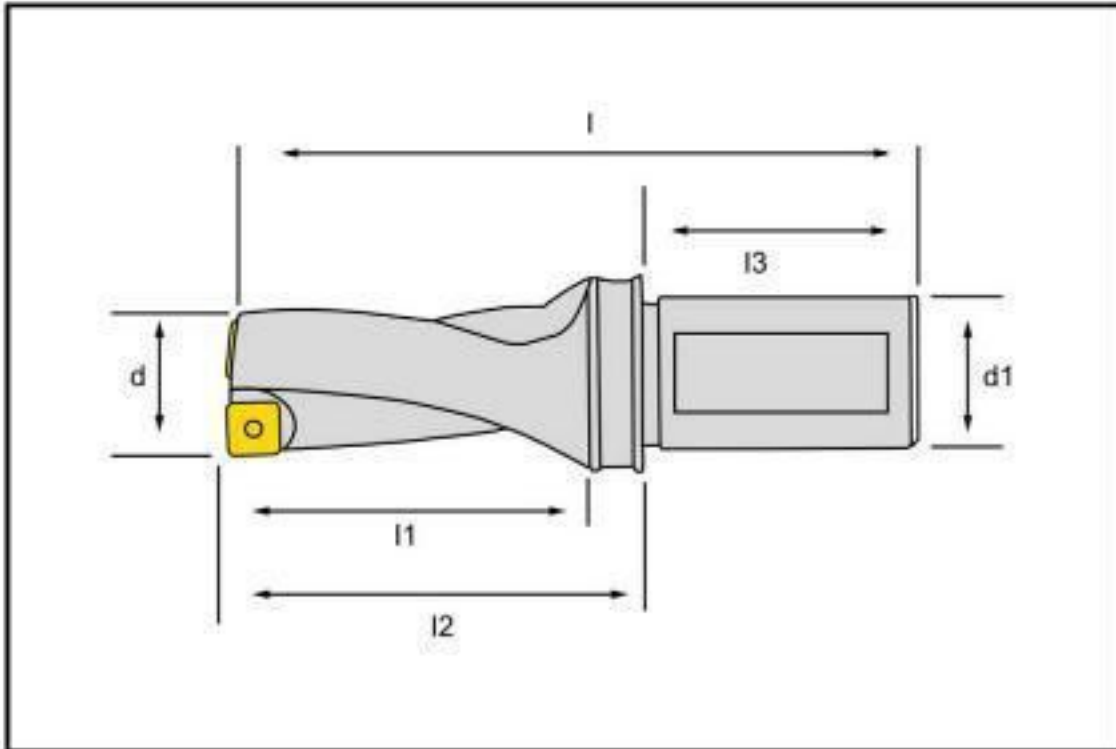
U -Drill





KOD CODE	ÖLÇÜLER DIMENSION (mm)							KESİCİ UÇ INSERT	YEDEK PARÇALAR SPARE PARTS			
	D	d1	d2	L	L1	L2	Ls		Sıkma Vidası Clamp Screw	Anahtar Torx Key		
SPMT D3-D4 U-DRILL												
SDUM 13 xD3	13	20	25	107	39	57	50	SPMT 050203	SSV M2x6	T06	D3	
SDUM 13,5 xD3	13,5	20	25	110	40,5	60	50					
SDUM 14 xD3	14	20	25	110	42	60	50					
SDUM 14,5 xD3	14,5	20	25	113	43,5	63	50					
SDUM 15 xD3	15	20	25	113	45	63	50					
SDUM 15,5 xD3	15,5	20	25	118	46,5	68	50					
SDUM 16 xD3	16	25	34	124	48	68	56					
SDUM 16,5 xD3	16,5	25	34	127	49,5	71	56					
SDUM 17 xD3	17	25	34	127	51	71	56					
SDUM 17,5 xD3	17,5	25	34	131	52,5	75	56					
SDUM 18 xD3	18	25	34	131	54	75	56					
SDUM 18,5 xD3	18,5	25	34	134	55,5	78	56					
SDUM 19 xD3	19	25	34	134	57	78	56					
SDUM 19,5 xD3	19,5	25	34	139	58,5	83	56					
SDUM 20 xD3	20	25	34	139	60	83	56					
SDUM 20,5 xD3	20,5	25	34	144	61,5	86	56					
SDUM 21 xD3	21	25	34	144	63	86	56					
SDUM 21,5 xD3	21,5	25	34	145	64,5	89	56					
SDUM 22 xD3	22	25	34	145	66	89	56					
SDUM 22,5 xD3	22,5	25	34	150	67,5	94	56					
SDUM 23 xD3	23	25	34	150	69	94	56					
SDUM 23,5 xD3	23,5	25	34	154	70,5	98	56					
SDUM 24 xD3	24	25	34	154	72	98	56					
SDUM 24,5 xD3	24,5	25	34	158	73,5	102	56					
SDUM 25 xD3	25	25	34	158	75	102	56					
SDUM 13 xD4	13	20	25	120	52	70	50	SPMT 050203	SSV M2x6	T06	D4	
SDUM 14 xD4	14	20	25	124	56	74	50					
SDUM 15 xD4	15	20	25	128	60	78	50					
SDUM 16 xD4	16	25	34	140	64	84	56					
SDUM 17 xD4	17	25	34	144	68	88	56					
SDUM 18 xD4	18	25	34	149	72	93	56					
SDUM 19 xD4	19	25	34	153	76	97	56					
SDUM 20 xD4	20	25	34	159	80	103	56					
SDUM 21 xD4	21	25	34	163	84	107	56					
SDUM 22 xD4	22	25	34	167	88	111	56					
SDUM 23 xD4	23	25	34	173	92	117	56					
SDUM 24 xD4	24	25	34	178	96	122	56					
SDUM 25 xD4	25	25	34	183	100	127	56					
								SPMT 060204	SSV M2,26	T07		D4
								SPMT 070204	SSV M2,5x7,5	T08	D4	

DEĞİŞKEN UÇLU MATKAPLAR

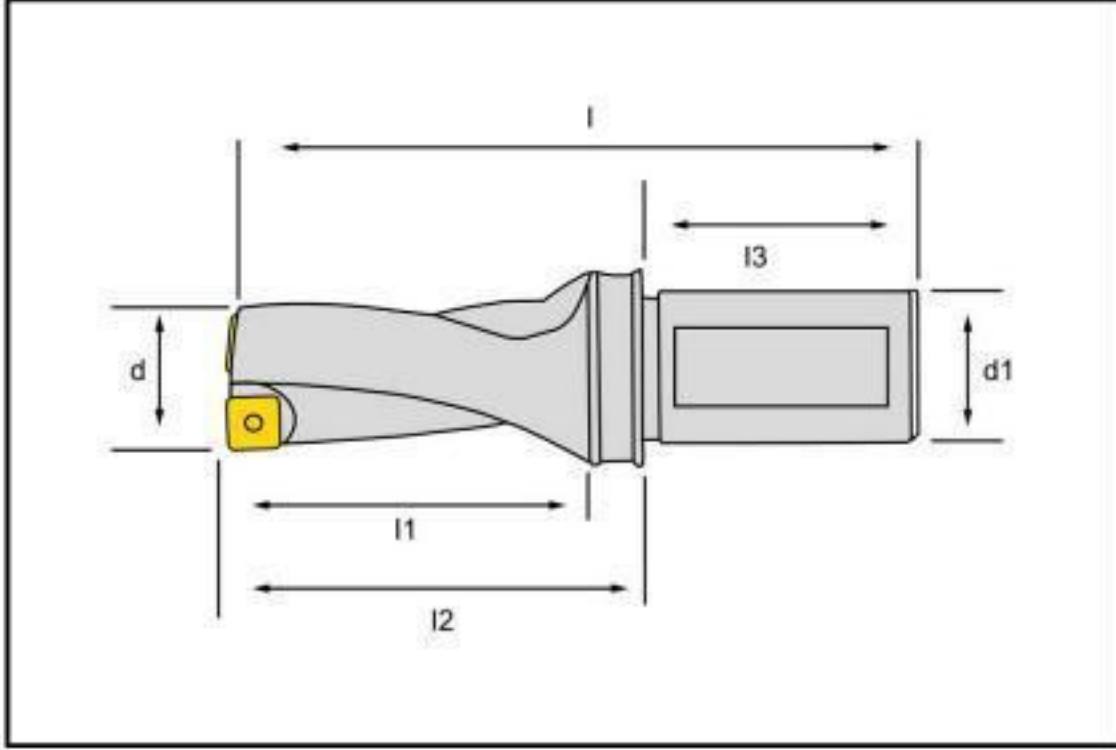
U-Drill





KOD CODE	ÖLÇÜLER DIMENSION (mm)							KEŞİTÇİ UÇ INSERT	YEDEK PARÇALAR SPARE PARTS	
	D	d1	d2	L	L1	L2	Ls		Sıkma Vidası Clamp Screw	Anahtar Torx Key
SPMG D2 U-DRILL										
SDUM 12,5 xD2	12,5	20	25	94	25	44	50	SPMG 050204	SSV M2x6	T06
SDUM 13 xD2	13	20	25	94	26	44	50			
SDUM 13,5 xD2	13,5	20	25	96	27	46	50			
SDUM 14 xD2	14	20	25	96	28	46	50			
SDUM 14,5 xD2	14,5	20	25	99	29	49	50			
SDUM 15 xD2	15	20	25	99	30	49	50			
SDUM 15,5 xD2	15,5	20	34	102	31	52	56			
SDUM 16 xD2	16	25	34	108	32	52	56			
SDUM 16,5 xD2	16,5	25	34	110	33	54	56			
SDUM 17 xD2	17	25	34	110	34	54	56			
SDUM 17,5 xD2	17,5	25	34	113	35	57	56			
SDUM 18 xD2	18	25	34	113	36	57	56			
SDUM 18,5 xD2	18,5	25	34	115	37	59	56			
SDUM 19 xD2	19	25	34	115	38	59	56			
SDUM 19,5 xD2	19,5	25	34	119	39	63	56			
SDUM 20 xD2	20	25	34	119	40	63	56			
SDUM 20,5 xD2	20,5	25	34	121	41	65	56			
SDUM 21 xD2	21	25	34	121	42	65	56			
SDUM 21,5 xD2	21,5	25	34	123	43	67	56			
SDUM 22 xD2	22	25	34	123	44	67	56			
SDUM 22,5 xD2	22,5	25	34	127	45	71	56			
SDUM 23 xD2	23	25	34	127	46	71	56			
SDUM 23,5 xD2	23,5	25	34	130	47	74	56			
SDUM 24 xD2	24	25	34	130	48	74	56			
SDUM 24,5 xD2	24,5	25	34	133	49	77	56			
SDUM 25 xD2	25	25	34	133	50	77	56			
SDUM 25,5 xD2	25,5	25	34	135	51	79	56			
SDUM 26 xD2	26	25	34	135	52	79	56			
								SPMG 060204	SSV M2,2x6	T07
								SPMG 07T308	SSV M2,5x7,5	T08

DEĞİŞKEN UÇLU MATKAPLAR

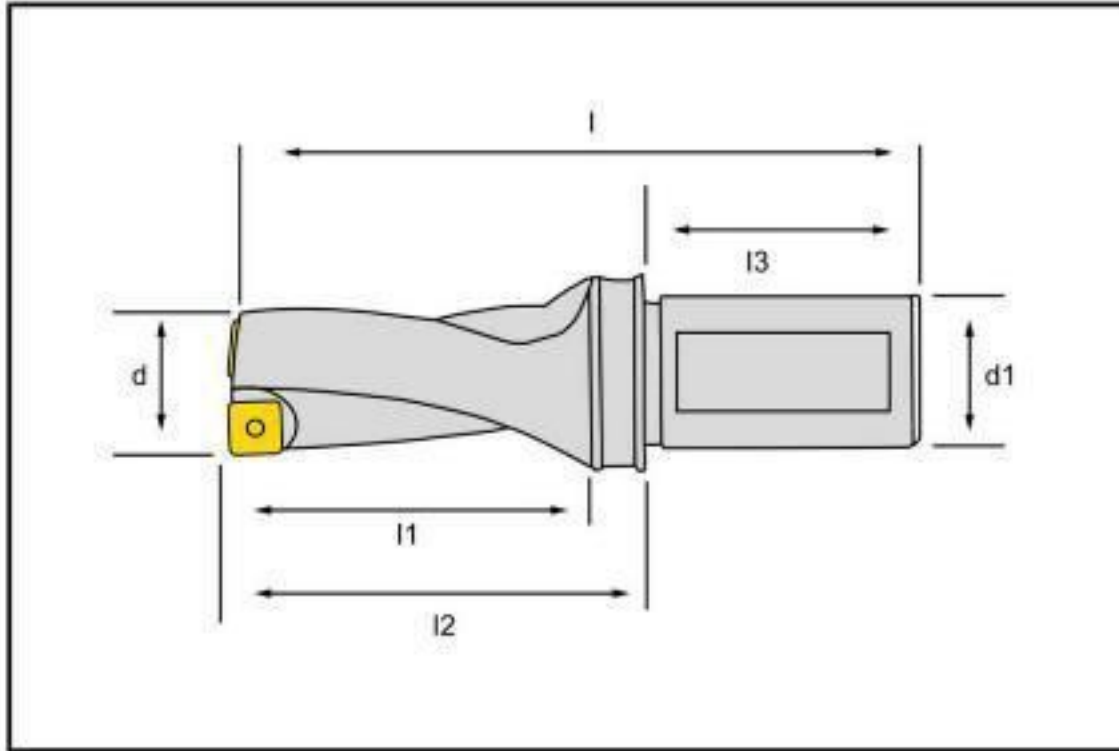
U-Drill





KOD CODE	ÖLÇÜLER DIMENSION (mm)							KESİCİ UÇ INSERT	YEDEK PARÇALAR SPARE PARTS	
	D	d1	d2	L	L1	L2	Ls		Sıkma Vidası Clamp Screw	Anahtar Torx Key
SPMG D2 U-DRILL	D	d1	d2	L	L1	L2	Ls			
SDUM 26,5 xD2	26,5	25	34	137	53	81	56	SPMG 07T308	SSV M2,5x7,5	T008
SDUM 27 xD2	27	25	34	137	54	81	56			
SDUM 27,5 xD2	27,5	25	34	140	55	84	56			
SDUM 28 xD2	28	25	34	140	56	84	56	SPMG 090408	SSV M3,5x9	T15
SDUM 28,5 xD2	28,5	25	34	142	57	86	56			
SDUM 29 xD2	29	25	34	142	58	86	56			
SDUM 29,5 xD2	29,5	25	34	151	59	91	56			
SDUM 30 xD2	30	32	44	151	60	91	60			
SDUM 31 xD2	31	32	44	154	62	94	60			
SDUM 32 xD2	32	32	44	156	64	96	60			
SDUM 33 xD2	33	32	44	159	66	99	60	SPMG 110408	SSV M4x11	T15
SDUM 34 xD2	34	32	44	161	68	101	60			
SDUM 35 xD2	35	32	44	164	70	104	60			
SDUM 36 xD2	36	32	44	167	72	107	60			
SDUM 37 xD2	37	32	44	170	74	110	60			
SDUM 38 xD2	38	32	44	173	76	113	60			
SDUM 39 xD2	39	32	44	175	78	115	60			
SDUM 40 xD2	40	32	44	178	80	118	60	SPMG 140512	SSV M5x11	T20
SDUM 41 xD2	41	32	44	181	82	121	60			
SDUM 42 xD2	42	32	44	183	84	123	60			
SDUM 43 xD2	43	32	44	186	86	126	60			
SDUM 44 xD2	44	32	44	188	88	128	60			
SDUM 45 xD2	45	40	54	202	90	132	60			
SDUM 46 xD2	46	40	54	205	92	135	70			
SDUM 47 xD2	47	40	54	207	94	137	70			
SDUM 48 xD2	48	40	54	210	96	140	70			
SDUM 49 xD2	49	40	54	212	98	142	70			
SDUM 50 xD2	50	40	54	215	100	145	70			

DEĞİŞKEN UÇLU MATKAPLAR

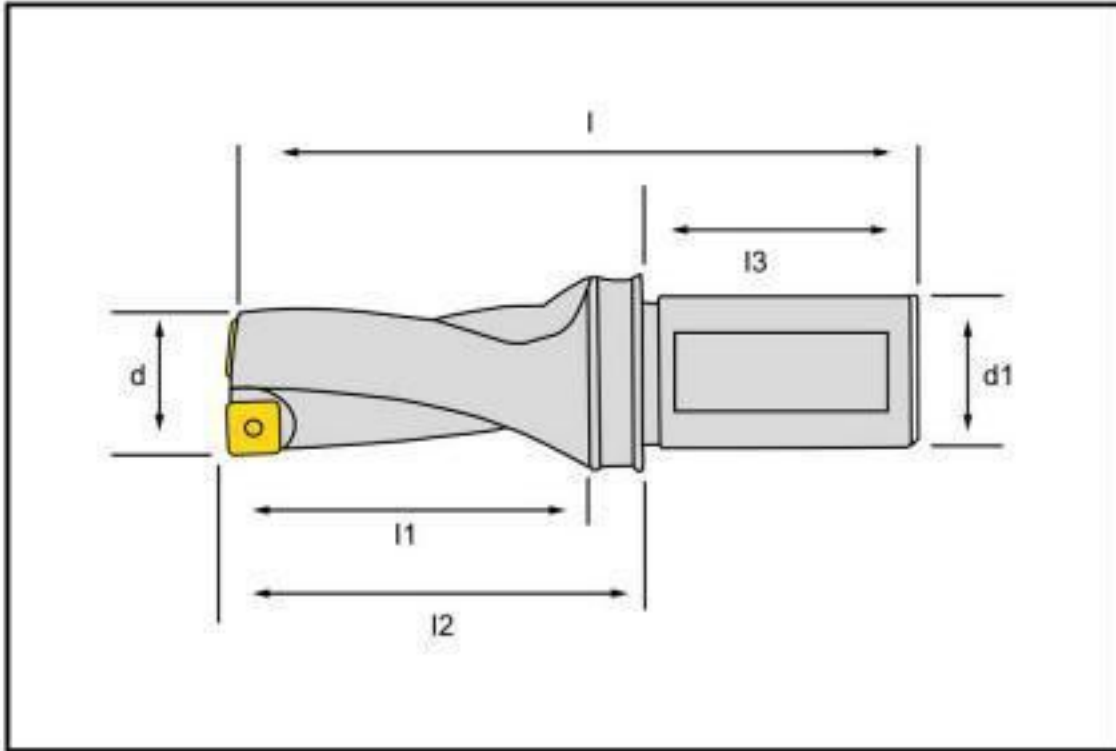
U-Drill





KOD CODE	ÖLÇÜLER DIMENSION (mm)							KEŞİTİ UÇ INSERT	YEDEK PARÇALAR SPARE PARTS	
	D	d1	d2	L	L1	L2	Ls		Sıkma Vidası Clamp Screw	Anahtar Torx Key
SPMG D3 U-DRILL										
SDUM 12,5 xD3	12,5	20	25	107	37	39	57	SPMG 050204	SSV M2x6	T06
SDUM 13 xD3	13	20	25	107	39	39	57			
SDUM 13,5 xD3	13,5	20	25	110	40,5	42	60			
SDUM 14 xD3	14	20	25	110	42	42	60			
SDUM 14,5 xD3	14,5	20	25	113	43,5	45	63			
SDUM 15 xD3	15	20	25	113	45	45	63			
SDUM 15,5 xD3	15,5	20	25	118	46,5	48	68			
SDUM 16 xD3	16	25	34	124	48	48	68			
SDUM 16,5 xD3	16,5	25	34	127	49,5	51	71			
SDUM 17 xD3	17	25	34	127	51	51	71			
SDUM 17,5 xD3	17,5	25	34	131	52,5	54	75	SPMG 060204	SSV M2,2x6	T07
SDUM 18 xD3	18	25	34	131	54	54	75			
SDUM 18,5 xD3	18,5	25	34	134	55,5	57	78			
SDUM 19 xD3	19	25	34	134	57	57	78			
SDUM 19,5 xD3	19,5	25	34	139	58,5	60	83			
SDUM 20 xD3	20	25	34	139	60	60	83			
SDUM 20,5 xD3	20,5	25	34	142	61,5	63	86			
SDUM 21 xD3	21	25	34	142	63	63	86			
SDUM 21,5 xD3	21,5	25	34	145	64,5	66	89			
SDUM 22 xD3	22	25	34	145	66	66	89			
SDUM 22,5 xD3	22,5	25	34	150	67,5	69	94	SPMG 07T308	SSV M2,5x7,5	T08
SDUM 23 xD3	23	25	34	150	69	69	94			
SDUM 23,5 xD3	23,5	25	34	154	70,5	72	98			
SDUM 24 xD3	24	25	34	158	72	72	98			
SDUM 24,5 xD3	24,5	25	34	158	73,5	75	102			
SDUM 25 xD3	25	25	34	161	75	75	102			
SDUM 25,5 xD3	25,5	25	34	161	76,5	78	105			
SDUM 26 xD3	26	25	34	164	78	78	105			

DEĞİŞKEN UÇLU MATKAPLAR

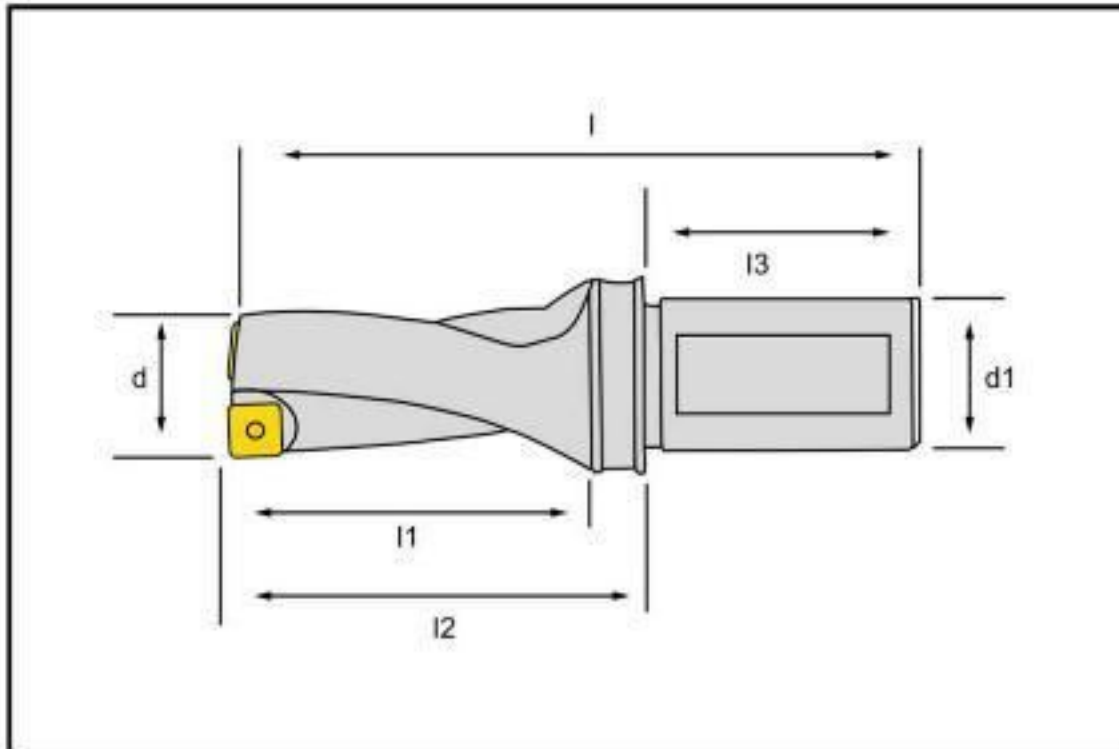
U -Drill



KOD CODE	ÖLÇÜLER DIMENSION (mm)							KESİCİ UÇ INSERT	YEDEK PARÇALAR SPARE PARTS	
	D	d1	d2	L	L1	L2	Ls		Sıkma Vidası Clamp Screw	Anahtar Torx Key
SPMG D3 U-DRILL										
SDUM 26,5 xD3	26,5	25	44	137	79,5	108	56	SPMG 07T308	SSV M2,5x7,5	T008
SDUM 27 xD3	27	25	44	137	81	108	56			
SDUM 27,5 xD3	27,5	25	44	140	82,5	112	56			
SDUM 28 xD3	28	25	44	140	84	112	56	SPMG 090408	SSV M3,5x9	T15
SDUM 28,5 xD3	28,5	25	44	142	85,5	115	56			
SDUM 29 xD3	29	25	44	142	87	115	56			
SDUM 29,5 xD3	29,5	25	44	151	88,5	121	56			
SDUM 30 xD3	30	32	44	151	90	121	60			
SDUM 31 xD3	31	32	44	154	93	125	60			
SDUM 32 xD3	32	32	44	156	96	128	60			
SDUM 33 xD3	33	32	44	159	99	132	60	SPMG 110408	SSV M4x11	T15
SDUM 34 xD3	34	32	44	161	102	135	60			
SDUM 35 xD3	35	32	44	164	105	139	60			
SDUM 36 xD3	36	32	44	167	108	143	60			
SDUM 37 xD3	37	32	44	170	111	147	60			
SDUM 38 xD3	38	32	44	173	114	151	60			
SDUM 39 xD3	39	32	44	175	117	154	60			
SDUM 40 xD3	40	32	44	178	120	158	60			
SDUM 41 xD3	41	32	44	181	123	162	60	SPMG 140512	SSV M5x11	T20
SDUM 42 xD3	42	32	44	183	126	165	60			
SDUM 43 xD3	43	32	44	186	129	169	60			
SDUM 44 xD3	44	32	44	188	132	172	60			
SDUM 45 xD3	45	40	54	202	135	177	70			
SDUM 46 xD3	46	40	54	205	138	181	70			
SDUM 47 xD3	47	40	54	207	141	184	70			
SDUM 48 xD3	48	40	54	210	144	188	70			
SDUM 49 xD3	49	40	54	212	147	191	70			
SDUM 50 xD3	50	40	54	215	150	195	70			
SDUM 51 xD3	51	40	60	217	153	198	70			
SDUM 52 xD3	52	40	60	220	156	201	70			
SDUM 53 xD3	53	40	60	222	159	204	70			
SDUM 54 xD3	54	40	60	225	162	207	70			
SDUM 55 xD3	55	40	60	227	165	210	70			
SDUM 56 xD3	56	40	60	230	168	213	70			
SDUM 57 xD3	57	40	60	232	171	216	70			
SDUM 58 xD3	58	40	60	235	174	219	70			
SDUM 59 xD3	59	40	60	237	177	222	70			
SDUM 60 xD3	60	40	60	240	180	225	70			

DEĞİŞKEN UÇLU MATKAPLAR

U-Drill

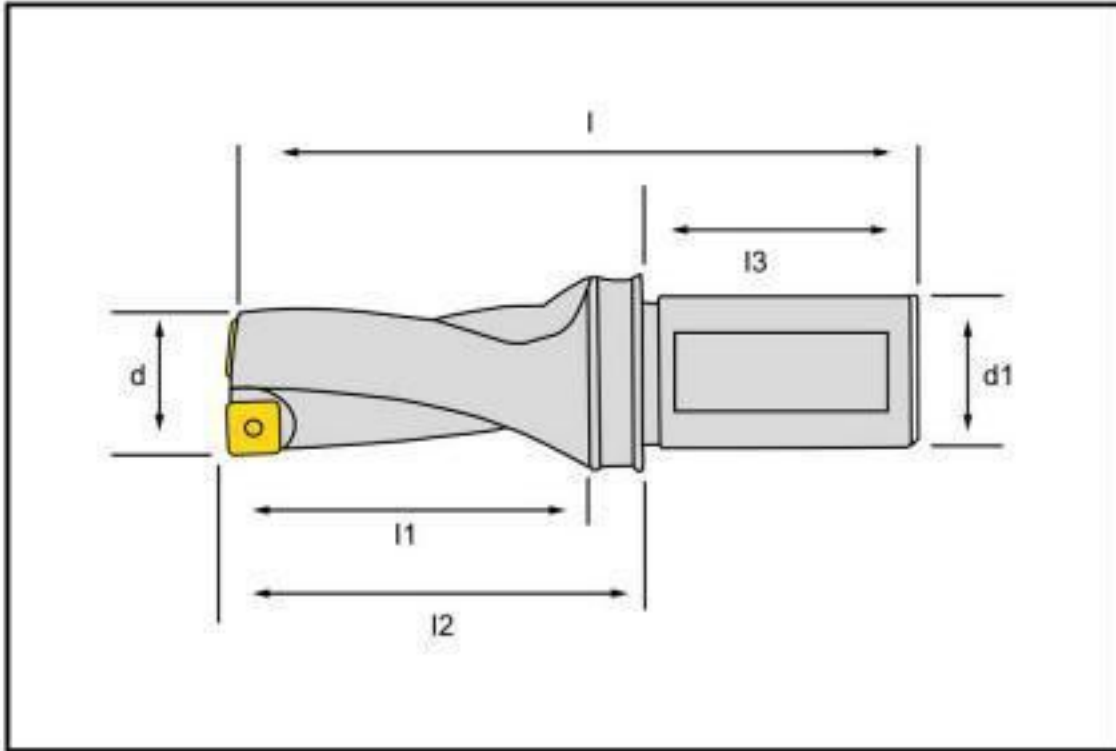

KOD CODE	ÖLÇÜLER DIMENSION (mm)							KESİCİ UÇ INSERT	YEDEK PARÇALAR SPARE PARTS	
	D	d1	d2	L	L1	L2	Ls		Sıkma Vidası Clamp Screw	Anahtar Torx Key
SPMG D4 U-DRILL										
SDUM 13xD4	13	20	25	120	52	70	50	SPMG 050204	SSV M2x6	T06
SDUM 14xD4	14	20	25	124	56	74	50			
SDUM 15xD4	15	20	25	128	60	78	50			
SDUM 16xD4	16	25	34	140	64	84	56			
SDUM 17xD4	17	25	34	144	68	88	56	SPMG 060204	SSV M2,2x6	T07
SDUM 18xD4	18	25	34	149	72	93	56			
SDUM 19xD4	19	25	34	153	76	97	56			
SDUM 20xD4	20	25	34	159	80	103	56			
SDUM 21xD4	21	25	34	163	84	107	56	SPMG 07T308	SSV M2,5x7,5	T08
SDUM 22xD4	22	25	34	167	88	111	56			
SDUM 23xD4	23	25	34	173	92	117	56			
SDUM 24xD4	24	25	34	178	96	122	56			
SDUM 25xD4	25	25	34	183	100	127	56	SPMG 090408	SSV M3,5x9	T15
SDUM 26xD4	26	25	34	187	104	131	56			
SDUM 27xD4	27	25	34	191	108	135	56			
SDUM 28xD4	28	25	34	196	112	140	56			
SDUM 29xD4	29	25	34	200	116	144	56	SPMG 110408	SSV M4x11	T15
SDUM 30xD4	30	32	44	211	120	151	60			
SDUM 31xD4	31	32	44	216	124	156	60			
SDUM 32xD4	32	32	44	220	128	160	60			
SDUM 33xD4	33	32	44	225	132	165	60	SPMG 140512	SSV M5x11	T20
SDUM 34xD4	34	32	44	229	136	169	60			
SDUM 35xD4	35	32	44	234	140	174	60			
SDUM 36xD4	36	32	44	239	144	179	60			
SDUM 37xD4	37	32	44	244	148	184	60	SPMG 140512	SSV M5x11	T20
SDUM 38xD4	38	32	44	249	152	189	60			
SDUM 39xD4	39	32	44	253	156	193	60			
SDUM 40xD4	40	32	44	258	160	198	60			
SDUM 41xD4	41	32	44	263	164	203	60	SPMG 140512	SSV M5x11	T20
SDUM 42xD4	42	32	44	267	168	207	60			
SDUM 43xD4	43	32	44	272	172	212	60			
SDUM 44xD4	44	32	44	276	176	216	60			

DEĞİŞKEN UÇLU MATKAPLAR

U -Drill

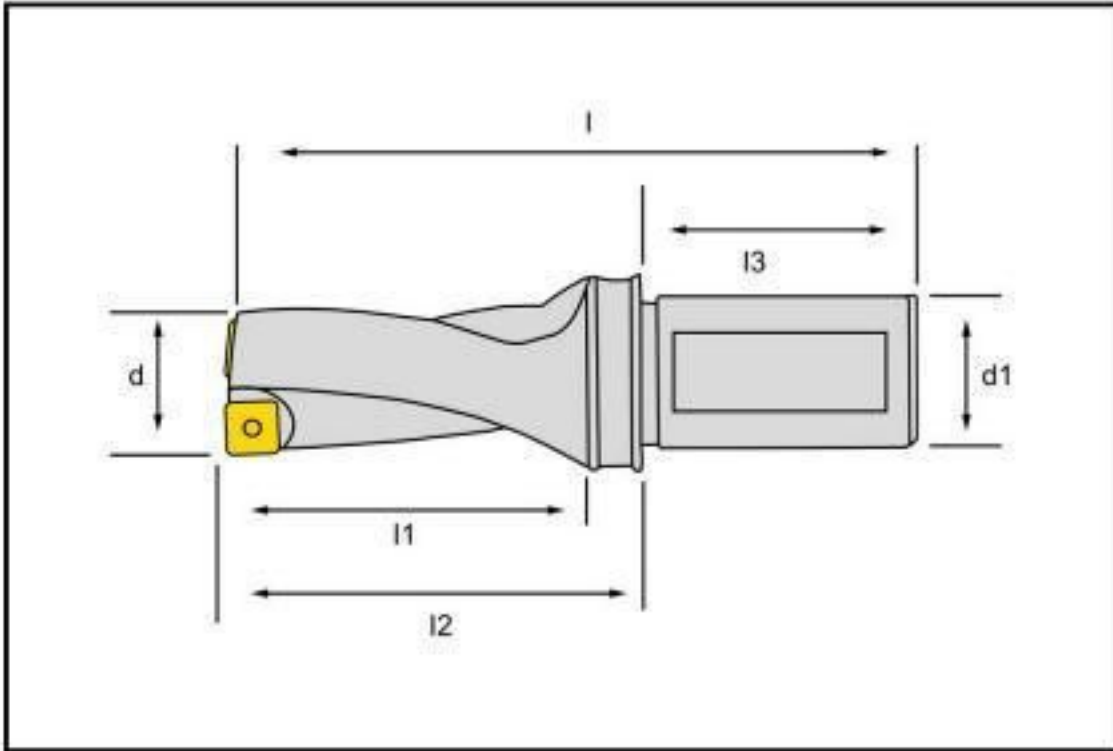

KOD CODE	ÖLÇÜLER DIMENSION (mm)							KESİCİ UÇ INSERT	YEDEK PARÇALAR SPARE PARTS	
	D	d1	d2	L	L1	L2	Ls		Sıkma Vidası Clamp Screw	Anahtar Torx Key
SPMG D5 U-DRILL										
SDUM 13xD5	13	20	25	138	65	85	50	SPMG 050204	SSV M2x6	T06
SDUM 14xD5	14	20	25	142	70	90	50			
SDUM 15xD5	15	20	25	146	75	95	50			
SDUM 16xD5	16	25	34	150	80	100	56	SPMG 060204	SSV M2,2x6	T07
SDUM 17xD5	17	25	34	161	85	105	56			
SDUM 18xD5	18	25	34	167	90	111	56			
SDUM 19xD5	19	25	34	172	95	116	56	SPMG 07T308	SSV M2,5x7,5	T08
SDUM 20xD5	20	25	34	179	100	123	56			
SDUM 21xD5	21	25	34	184	105	128	56			
SDUM 22xD5	22	25	34	189	110	133	56	SPMG 090408	SSV M3,5x9	T15
SDUM 23xD5	23	25	34	193	115	137	56			
SDUM 24xD5	24	25	34	198	120	142	56			
SDUM 25xD5	25	25	34	203	125	147	56	SPMG 110408	SSV M4x11	T15
SDUM 26xD5	26	25	34	207	130	151	56			
SDUM 27xD5	27	25	34	211	135	156	56			
SDUM 28xD5	28	25	34	216	140	162	56			
SDUM 29xD5	29	25	34	220	145	166	56			
SDUM 30xD5	30	32	34	224	150	171	60			

TIRTIR ve PUNTALAMA TAKIMLARI Center Tools



KOD CODE	ÖLÇÜLER DIMENSION (mm)			
	h	b	L	f
CNC PUNTA				
25x25 2.5x6 CNC PUNTA	25	25	150	12,5
25x25 3.15x8 CNC PUNTA	25	25	150	12,5
20x20 2.5x6 CNC PUNTA	20	20	125	10
20x20 3.15x8 CNC PUNTA	20	20	125	10



KOD CODE	ÖLÇÜLER DIMENSION (mm)			
	h	b	L	f
CNC TIRTIR				
25x25 CNC TIRTIR KATERİ	25	25	150	12,5
20x20 CNC TIRTIR KATERİ	20	20	125	10
25x25 TIRTIR KATERİ	25	25	150	12,5
20x20 TIRTIR KATERİ	20	20	125	10
25x25 ÇİFTLİ TIRTIR KATERİ	25	25	150	12,5





YEDEK PARÇALAR

SPARE PARTS

YEDEK PARÇALAR Spare Parts

T SİSTEM BASKI PARÇALARI

T System Clamps

ÜRÜN PRODUCT	DETAY DETAILS
TSK-1	DNMG15 CNMG12 WNMG08 SNMG12 TNMG22
	
TSK-4	CNM CNMG19
	

ÜRÜN PRODUCT	DETAY DETAILS
TSK-2	DNMG11, TNMG16 WNMG06
	
TSK-5	VNMG16
	

ÜRÜN PRODUCT	DETAY DETAILS
TSK-3	CNMG16, SNMG15
	

M SİSTEM BASKI PARÇALARI

M System Clamps

ÜRÜN PRODUCT	DETAY DETAILS
MSK-1	TNMG16, TNMG22
	
MSK-4	WNMG06
	

ÜRÜN PRODUCT	DETAY DETAILS
MSK-2	TNMG-16 (S16P MTUNR-16)
	

ÜRÜN PRODUCT	DETAY DETAILS
MSK-3	WNMG08
	

C SİSTEM BASKI PARÇALARI

C System Clamps

ÜRÜN PRODUCT	DETAY DETAILS
CSK/R	KNUX16/R
	
RTBP-1	RD10,12 RDMT FREZELER İÇİN FOR RDMT MILLS
	

ÜRÜN PRODUCT	DETAY DETAILS
CSK/L	KNUX16/L
	
BDTK	DİŞ AÇMA TAKIMLARI İÇİN FOR THREADING TOOLS
	

YEDEK PARÇALAR Spare Parts

ALTLIKLAR

Shims

ÜRÜN PRODUCT	DETAY DETAILS
BAX-DN15	
	DNMG15 ALTLIK DNMG15 SHIM
BAX-CN12	
	CNMG12 ALTLIK CNMG12 SHIM
BAX-SN12	
	SNMG12 ALTLIK SNMG12 SHIM
BAX-TN16	
	TNMG16 ALTLIK TNMG16 SHIM
BAX-CC12	
	CCMT12 ALTLIK CCMT12 SHIM
BAX-TC16	
	TCMT16 ALTLIK TCMT16 SHIM
BAX-SC09	
	SCMT09 ALTLIK SCMT09 SHIM

ÜRÜN PRODUCT	DETAY DETAILS
BAX-DN11	
	DNMG11 ALTLIK DNMG11 SHIM
BAX-CN16	
	CNMG16 ALTLIK CNMG16 SHIM
BAX-SN15	
	SNMG15 ALTLIK SNMG15 SHIM
BAX-TN22	
	TNMG16 ALTLIK TNMG22 SHIM
BAX-VB16	
	VBMT16 ALTLIK VBMT16 SHIM
BAX-KN/R16	
	KNUX/R16 ALTLIK KNUX/R SHIM
BAX-SC12	
	SCMT12 ALTLIK SCMT12 SHIM

ÜRÜN PRODUCT	DETAY DETAILS
BAX-DC11	
	DCMT11 ALTLIK DCMT11 SHIM
BAX-CN19	
	CNMG19 ALTLIK CNMG19 SHIM
BAX-WN08	
	WNMG08 ALTLIK WNMG08 SHIM
BAX-VN16	
	VNMG16 ALTLIK VNMG16 SHIM
BAX-ER/L16	
	ER/L16 ALTLIK ER/L16 SHIM
BAX-KN/L16	
	KNUX/L16 ALTLIK KNUX/L16 SHIM

YEDEK PARÇALAR

Spare Parts

BASKI PARÇA VİDALARI

Clamp Screws

ÜRÜN PRODUCT	DETAY DETAILS
TSBV-M5x25 	DNMG11, WNMG06 TNMG16 (S16)
TSBV-M8x30 	CNMG19
BKTV-M4x15 	S16 BIKT

ÜRÜN PRODUCT	DETAY DETAILS
TSBV-M6x30 	DNMG15, WNMG08 TNMG16, TNMG22 CNMG12, SNMG12, VNMG16
BKTV-M6x25 	2020, 2525, 3232 (BDKT) S25, S32, S40 (BIKT) 2525 CKJNR/L, S25, S32 CKUNR/L
TPBV-M6x20 	TPKN16 TARAMA TPKN16 FACE MILL

ÜRÜN PRODUCT	DETAY DETAILS
TSBV-M6x30x7 	CNMG16, SNMG15
BKTV-M5x12 	1212, 1616 BDKT S16, S20 BIKT
TPBV-M8x25 	TPKN22 TARAMA TPKN22 FACE MILL

ALTLIK VİDA ve PİMLERİ

Shim Screw and Pins

TSAV-M4x10 	DNMG11, DNMG15, WNMG08 CNMG12, SNMG12 TNMG16, VNMG16
SBV-M5x05 A3.5x11 	DCMT11, VBMT16 SCMT09, CCMT09 TCMT16, ER/L16
BMP2-5x6 	TNMG22

TSAV-M6x10 	CNMG16, CNMG16 SNMG15
SBV-M7x05 A4.5x11 	CCMT12, SCMT12L
BMP3-5x6 	WNMG08

CSAV-M3x10 	KNUX R/L
BMP1-3.70x5 	TNMG16, WNMG06

YEDEK PARÇALAR Spare Parts

TORK VİDALAR Torx Screws

ÜRÜN PRODUCT	DETAY DETAILS	ÜRÜN PRODUCT	DETAY DETAILS	ÜRÜN PRODUCT	DETAY DETAILS
SSV-M2x6	SP.050204 SPMT 050203	SSV-M2.2x6	SP.060204 SPMT 060204	SSV-M2.5x7	SP.07T308, SPMT070204 WCM.06T308, (S SİSTEM/S SYSTEM) S06,S08 S10,S12,S16,S20 0808,1010,1616 APKT10-11,R390.11
SSV-M3x9	WCMX 050308	SSV-M3.5x11	SP.090408, WCMX06T308 (S SİSTEM/S SYSTEM) S16,S20,S25 APKT12-16-17,12 RD10-,AD15,R390.17 SE12,XO12,OD05, SD09,VC16	SSV-M3.5x14	(S SİSTEM /S SYSTEM) S32,S40 1616,2020, 2525,3232 1616,2020, 2525,3232
SSV-M4x11	SP.110408, SN12	SSV-M4.5x11	CC12, SC12, TC12, SD12,	SSV-M5x11	SP.140512
SNSV-M5x10	PUNTA TAKIMI CENTER TOOL	TC170-M3x7	P3208	TC172-M4x05x9	P3210 ROHX 1203 (KÜRE TARAMALAR/ BALL MILLS)
TC174-M5x05x9	P3212 ROHX 1604 (KÜRE TARAMALAR / BALL MILLS)	TC176-M5x05x12	P3216 (KÜRE TARAMALAR / BALL MILLS)	TC178-M5x05x15	P3220, ROHX2005 (KÜRE TARAMALAR / BALL MILLS)
TC181-M6x0.75x20	P3225 (KÜRE TARAMALAR / BALL MILLS)	TC184-M8x0.75x24	P3232 (KÜRE TARAMALAR / BALL MILLS)		
CSP 6.5x12	PUL / STAMP	BAX-Y25	YAY / SPRING		

ANAHTARLAR Keys

TORK ANAHTAR TORX KEY	ALYAN ANAHTAR ALLEN KEY
T06 T07 T08 T15 T20	AA3 AA4 AA5

